



# Katalog Catalogue



Rotore Rotors	2	
Verteilerkappen Distributor Caps	18	
Impulsgeber Impulse Senders	Zündmodule Ignition Modules	42
Zündspulen Ignition Coils	50	
Zündleitungen Ignition Leads	77	
Zündleitungssätze Ignition Cable Sets	Zündkabel Ignition Cables	188
Zündkerzenstecker Spark Plug Terminals	207	
Verteiler-/Zündspulenstecker Distributor-/Ignition Coil Terminals	222	
Anschlußhülsen Connecting Sleeves	228	
Verkaufsbedingungen Conditions of sale	229	



**7001**  
Zündsystem / system  
**Bosch**  
Polyester/Polyester  
1000 Ohm entstört/suppressed

Verwendung für: / applicable for:  
ALFA ROMEO  
AUDI  
FORD  
HOLDEN  
HYUNDAI  
MERCEDES-BENZ  
NISSAN  
OPEL  
SAAB  
SEAT  
SKODA  
VAUXHALL  
VOLVO  
VW



**7002**  
Zündsystem / system  
**Bosch**  
Polyester/Polyester  
1000 Ohm entstört/suppressed

Verwendung für: / applicable for:  
VOLVO



**7003**  
Zündsystem / system  
**Bosch**  
Polyester/Polyester  
1000 Ohm entstört/suppressed  
Max. Drehzahl/RPM: 5700 /min.

Verwendung für: / applicable for:  
VW



**7004**  
Zündsystem / system  
**Bosch**  
Polyester/Polyester  
1000 Ohm entstört/suppressed

Verwendung für: / applicable for:  
ALFA ROMEO  
ALPINE  
BMW  
CITROEN  
LANCIA  
PEUGEOT  
RENAULT  
ROLLS-ROYCE  
VOLVO



**7005**  
Zündsystem / system  
**Bosch**  
Polyester/Polyester  
1000 Ohm entstört/suppressed

Verwendung für: / applicable for:  
ALFA ROMEO  
BMW  
OPEL  
PORSCHE  
VAUXHALL



**7006**  
Zündsystem / system  
**Bosch**  
Isolierstoff/Insulating material  
1000 Ohm entstört/suppressed

Verwendung für: / applicable for:  
ALFA ROMEO  
SAAB



**7007**  
Zündsystem / system  
**Bosch**  
Polyester/Polyester  
1000 Ohm entstört/suppressed  
Max. Drehzahl/RPM: 6350 /min.

Verwendung für: / applicable for:  
VW



**7008**  
Zündsystem / system  
**Bosch**  
Polyester/Polyester  
1000 Ohm entstört/suppressed

Verwendung für: / applicable for:  
MERCEDES-BENZ



**7009**  
Zündsystem / system  
**Bosch**  
Polyester/Polyester  
1000 Ohm entstört/suppressed

Verwendung für: / applicable for:  
HOLDEN  
OPEL  
VAUXHALL



**7010**  
Zündsystem / system  
**Bosch**  
Polyester/Polyester  
1000 Ohm entstört/suppressed  
Max. Drehzahl/RPM: 6200 /min.

Verwendung für: / applicable for:  
VOLVO



**7023**  
Zündsystem / system  
**Bosch**  
Epoxyharz/Epoxy resin  
1000 Ohm entstört/suppressed

Verwendung für: / applicable for:  
MERCEDES-BENZ



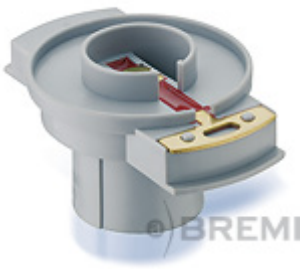

**7025**  
Zündsystem / system  
**Bosch**  
Polyester/Polyester  
1000 Ohm entstört/suppressed  
Verwendung für: / applicable for:  
FORD



**7035**  
Zündsystem / system  
**Bosch**  
Polyester/Polyester  
1000 Ohm entstört/suppressed  
Verwendung für: / applicable for:  
PORSCHÉ



**7026**  
Zündsystem / system  
**Bosch**  
Polyester/Polyester  
1000 Ohm entstört/suppressed  
Verwendung für: / applicable for:  
MERCEDES-BENZ



**7036**  
Zündsystem / system  
**Marelli**  
Polypropylen/Polypropylen  
1000 Ohm entstört/suppressed  
Verwendung für: / applicable for:  
PORSCHÉ



**7027**  
Zündsystem / system  
**Bosch**  
Polyester/Polyester  
1000 Ohm entstört/suppressed  
Verwendung für: / applicable for:  
MERCEDES-BENZ



**7037**  
Zündsystem / system  
**Bosch**  
Polyester/Polyester  
1000 Ohm entstört/suppressed  
Verwendung für: / applicable for:  
PORSCHÉ



**7028**  
Zündsystem / system  
**Bosch**  
Polyester/Polyester  
1000 Ohm entstört/suppressed  
Verwendung für: / applicable for:  
VOLVO



**7039**  
Zündsystem / system  
**Bosch**  
Polyester/Polyester  
1000 Ohm entstört/suppressed  
Verwendung für: / applicable for:  
VW



**7030**  
Zündsystem / system  
**Bosch**  
Polypropylen/Polypropylen  
1000 Ohm entstört/suppressed  
Verwendung für: / applicable for:  
BMW



**7041**  
Zündsystem / system  
**Bosch**  
Polypropylen/Polypropylen  
1000 Ohm entstört/suppressed  
Verwendung für: / applicable for:  
VW



**7031**  
Zündsystem / system  
**Bosch**  
Polypropylen/Polypropylen  
1000 Ohm entstört/suppressed  
Verwendung für: / applicable for:  
PORSCHÉ



**7042**  
Zündsystem / system  
**Bosch**  
Epoxyharz/Epoxy resin  
1000 Ohm entstört/suppressed  
Verwendung für: / applicable for:  
MERCEDES-BENZ



**7350**  
Zündsystem / system  
Ducellier  
Polyester/Polyester  
1000 Ohm entstört/suppressed  
Max. Drehzahl/RPM: 6800 /min.  
Verwendung für: / applicable for:  
ALFA ROMEO



**7382**  
Zündsystem / system  
Ducellier  
Polypropylen/Polypropylen  
1000 Ohm entstört/suppressed  
Verwendung für: / applicable for:  
CITROEN  
FIAT  
PEUGEOT



**7351**  
Zündsystem / system  
Ducellier  
Polyester/Polyester  
1000 Ohm entstört/suppressed  
Verwendung für: / applicable for:  
AUDI  
SEAT  
VW



**7430**  
Zündsystem / system  
Lucas  
Polypropylen/Polypropylen  
nicht entstört/not suppressed  
Verwendung für: / applicable for:  
LAND ROVER  
MORGAN



**7353**  
Zündsystem / system  
Ducellier  
Polypropylen/Polypropylen  
nicht entstört/not suppressed  
Verwendung für: / applicable for:  
RENAULT



**7501**  
Zündsystem / system  
Hitachi  
Polypropylen/Polypropylen  
nicht entstört/not suppressed  
Verwendung für: / applicable for:  
NISSAN



**7354**  
Zündsystem / system  
Ducellier  
Polypropylen/Polypropylen  
nicht entstört/not suppressed  
Verwendung für: / applicable for:  
CITROEN  
PEUGEOT



**7502**  
Zündsystem / system  
Ford  
Polypropylen/Polypropylen  
nicht entstört/not suppressed  
Verwendung für: / applicable for:  
HONDA



**7380**  
Zündsystem / system  
Ducellier  
PBT/PBT  
nicht entstört/not suppressed  
Verwendung für: / applicable for:  
RENAULT  
VOLVO



**7503**  
Zündsystem / system  
Hitachi  
Polypropylen/Polypropylen  
nicht entstört/not suppressed  
Verwendung für: / applicable for:  
HONDA  
ROVER



**7381**  
Zündsystem / system  
Ducellier  
Polypropylen/Polypropylen  
5000 Ohm entstört/suppressed  
Verwendung für: / applicable for:  
FIAT  
RENAULT  
VOLVO



**7504**  
Zündsystem / system  
Hitachi  
Polypropylen/Polypropylen  
nicht entstört/not suppressed  
Verwendung für: / applicable for:  
SUBARU



**7505**  
Zündsystem / system  
**Hitachi**  
Polypropylen/Polypropylen  
nicht entstört/not suppressed

Verwendung für: / applicable for:  
HONDA  
ROVER



**7506**  
Zündsystem / system  
**Hitachi**  
Polypropylen/Polypropylen  
nicht entstört/not suppressed

Verwendung für: / applicable for:  
NISSAN



**7508**  
Zündsystem / system  
**Hitachi**  
Polypropylen/Polypropylen  
nicht entstört/not suppressed

Verwendung für: / applicable for:  
HONDA



**7605**  
Zündsystem / system  
**Marelli**  
Isolierstoff/Insulating material  
5000 Ohm entstört/suppressed

Verwendung für: / applicable for:  
LADA  
LADA (Shiguli)  
ZAZ



**7606**  
Zündsystem / system  
**Marelli**  
Polyester/Polyester  
nicht entstört/not suppressed

Verwendung für: / applicable for:  
AUTOBIANCHI  
FIAT  
INNOCENTI  
LANCIA  
PEUGEOT  
RENAULT  
SEAT



**7607**  
Zündsystem / system  
**Marelli**  
Isolierstoff/Insulating material  
5000 Ohm entstört/suppressed

Verwendung für: / applicable for:  
ALFA ROMEO  
AUTOBIANCHI  
CITROEN  
FIAT  
SEAT



**7608**  
Zündsystem / system  
**Marelli**  
Isolierstoff/Insulating material  
nicht entstört/not suppressed

Verwendung für: / applicable for:  
CITROEN  
FIAT



**7609**  
Zündsystem / system  
**Marelli**  
Polyester/Polyester  
5000 Ohm entstört/suppressed

Verwendung für: / applicable for:  
AUTOBIANCHI  
FIAT  
INNOCENTI  
LANCIA  
PEUGEOT  
RENAULT  
SEAT



**7613**  
Zündsystem / system  
**Marelli**  
Polypropylen/Polypropylen  
5000 Ohm entstört/suppressed

Verwendung für: / applicable for:  
ALFA ROMEO  
AUTOBIANCHI  
FIAT  
LANCIA  
SEAT



**7615**  
Zündsystem / system  
**Marelli**  
Polypropylen/Polypropylen  
1000 Ohm entstört/suppressed

Verwendung für: / applicable for:  
ALFA ROMEO  
AUTOBIANCHI  
FIAT  
LANCIA



**7617**  
Zündsystem / system  
**Marelli**  
PBT/PBT  
nicht entstört/not suppressed

Verwendung für: / applicable for:  
AUTOBIANCHI  
FIAT  
LANCIA  
PEUGEOT



**7618**  
Zündsystem / system  
**Marelli**  
Polypropylen/Polypropylen  
1000 Ohm entstört/suppressed

Verwendung für: / applicable for:  
FIAT  
FORD  
LANCIA  
SEAT



**7620**  
Zündsystem / system  
**Marelli**  
Polypropylen/Polypropylen  
nicht entstört/not suppressed

Verwendung für: / applicable for:  
ALFA ROMEO  
FIAT  
LANCIA  
RENAULT



**7621**  
Zündsystem / system  
**Marelli**  
Polyester/Polyester  
1000 Ohm entstört/suppressed

Verwendung für: / applicable for:  
SEAT  
SKODA  
VW



**7701**  
Zündsystem / system  
**Chrysler**  
Polypropylen/Polypropylen  
nicht entstört/not suppressed

Verwendung für: / applicable for:  
CHRYSLER



**7702**  
Zündsystem / system  
**Chrysler**  
Polypropylen/Polypropylen  
nicht entstört/not suppressed

Verwendung für: / applicable for:  
CHRYSLER



**7703**  
Zündsystem / system  
**Chrysler**  
Polypropylen/Polypropylen  
nicht entstört/not suppressed

Verwendung für: / applicable for:  
CHRYSLER



**9027**  
Zündsystem / system  
**Bosch**  
Isolierstoff/Insulating material  
nicht entstört/not suppressed

Verwendung für: / applicable for:  
ALFA ROMEO  
CITROEN  
FORD  
OPEL  
RENAULT  
VAUXHALL  
VW



**9032**  
Zündsystem / system  
**Bosch**  
Isolierstoff/Insulating material  
5000 Ohm entstört/suppressed

Verwendung für: / applicable for:  
ALFA ROMEO  
BMW  
CITROEN  
FORD  
OPEL  
RENAULT  
VAUXHALL  
VOLVO  
VW



**9038**  
Zündsystem / system  
**Bosch**  
Isolierstoff/Insulating material  
5000 Ohm entstört/suppressed

Verwendung für: / applicable for:  
PEUGEOT  
RENAULT  
VW



**9045**  
Zündsystem / system  
**Bosch**  
Isolierstoff/Insulating material  
5000 Ohm entstört/suppressed

Verwendung für: / applicable for:  
SAAB



**9046**  
Zündsystem / system  
**Bosch**  
Polyester/Polyester  
5000 Ohm entstört/suppressed  
  
Verwendung für: / applicable for:  
AUDI



**9047**  
Zündsystem / system  
**Bosch**  
Polyester/Polyester  
5000 Ohm entstört/suppressed  
  
Verwendung für: / applicable for:  
VOLVO



**9048**  
Zündsystem / system  
**Bosch**  
Polyester/Polyester  
5000 Ohm entstört/suppressed  
  
Verwendung für: / applicable for:  
LANCIA  
MASERATI  
MERCEDES-BENZ  
PORSCHE  
RENAULT  
VOLVO



**9049**  
Zündsystem / system  
**Bosch**  
Polyester/Polyester  
5000 Ohm entstört/suppressed  
Max. Drehzahl/RPM: 6600 /min.  
  
Verwendung für: / applicable for:  
BMW  
OPEL  
PORSCHE  
VAUXHALL  
VW



**9050**  
Zündsystem / system  
**Bosch**  
**PAL**  
Polyester/Polyester  
5000 Ohm entstört/suppressed  
  
Verwendung für: / applicable for:  
AUDI  
VOLVO



**9051**  
Zündsystem / system  
**Bosch**  
Polyester/Polyester  
5000 Ohm entstört/suppressed  
  
Verwendung für: / applicable for:  
AUDI  
CITROEN  
PEUGEOT



**9053**  
Zündsystem / system  
**Bosch**  
Polyester/Polyester  
5000 Ohm entstört/suppressed  
Max. Drehzahl/RPM: 6350 /min.  
  
Verwendung für: / applicable for:  
BMW  
FORD  
OPEL  
VOLVO  
VW



**9054**  
Zündsystem / system  
**Bosch**  
Polyester/Polyester  
5000 Ohm entstört/suppressed  
Max. Drehzahl/RPM: 5400 /min.  
  
Verwendung für: / applicable for:  
OPEL  
VW



**9057**  
Zündsystem / system  
**Bosch**  
Polyester/Polyester  
5000 Ohm entstört/suppressed  
Max. Drehzahl/RPM: 6650 /min.  
  
Verwendung für: / applicable for:  
MERCEDES-BENZ



**9058**  
Zündsystem / system  
**Bosch**  
Polyester/Polyester  
5000 Ohm entstört/suppressed  
Max. Drehzahl/RPM: 6600 /min.  
  
Verwendung für: / applicable for:  
BMW



**9059**  
Zündsystem / system  
**Bosch**  
Polyester/Polyester  
5000 Ohm entstört/suppressed  
Max. Drehzahl/RPM: 6800 /min.  
  
Verwendung für: / applicable for:  
ALFA ROMEO



**9061**  
Zündsystem / system  
**Bosch**  
Polyester/Polyester  
5000 Ohm entstört/suppressed  
Max. Drehzahl/RPM: 5850 /min.  
  
Verwendung für: / applicable for:  
MERCEDES-BENZ





**9062**  
 Zündsystem / system  
**Bosch**  
 Polyester/Polyester  
 5000 Ohm entstört/suppressed  
 Max. Drehzahl/RPM: 6500 /min.  
 Verwendung für: / applicable for:  
 MERCEDES-BENZ



**9066**  
 Zündsystem / system  
**Bosch**  
 Polyester/Polyester  
 1000 Ohm entstört/suppressed  
 Verwendung für: / applicable for:  
 ALFA ROMEO  
 AUDI  
 BMW  
 DAF  
 FIAT  
 FORD  
 INNOCENTI  
 LANCIA  
 MERCEDES-BENZ  
 NISSAN  
 OPEL  
 PEUGEOT  
 PORSCHE  
 RENAULT  
 SAAB  
 SKODA  
 TALBOT  
 VAUXHALL  
 VOLVO  
 VW  
 ZASTAVA



**9071**  
 Zündsystem / system  
**Bosch**  
 Polyester/Polyester  
 5000 Ohm entstört/suppressed  
 Max. Drehzahl/RPM: 6500 /min.  
 Verwendung für: / applicable for:  
 AUDI  
 BMW  
 PORSCHE



**9072**  
 Zündsystem / system  
**Bosch**  
 Epoxyharz/Epoxy resin  
 1000 Ohm entstört/suppressed  
 Verwendung für: / applicable for:  
 BMW



**9073**  
 Zündsystem / system  
**Bosch**  
 Polyester/Polyester  
 1000 Ohm entstört/suppressed  
 Verwendung für: / applicable for:  
 ALFA ROMEO  
 AUDI  
 BEDFORD  
 CITROEN  
 FIAT  
 HOLDEN  
 OPEL  
 PEUGEOT  
 SAAB  
 SEAT  
 TALBOT  
 VAUXHALL  
 VW  
 WARTBURG



**9082**  
 Zündsystem / system  
**Bosch**  
 Polyester/Polyester  
 1000 Ohm entstört/suppressed  
 Verwendung für: / applicable for:  
 ALFA ROMEO  
 AUDI  
 BEDFORD  
 BMW  
 MERCEDES-BENZ  
 NISSAN  
 OPEL  
 PEUGEOT  
 PORSCHE  
 SAAB  
 SEAT  
 VAUXHALL  
 VOLVO  
 VW  
 ZASTAVA



**9083**  
 Zündsystem / system  
**Bosch**  
 Polyester/Polyester  
 1000 Ohm entstört/suppressed  
 Verwendung für: / applicable for:  
 ALFA ROMEO  
 BMW  
 FORD  
 MERCEDES-BENZ  
 OPEL  
 PORSCHE  
 VAUXHALL  
 VW



**9084**  
 Zündsystem / system  
**Bosch**  
 Polyester/Polyester  
 1000 Ohm entstört/suppressed  
 Max. Drehzahl/RPM: 6700 /min.  
 Verwendung für: / applicable for:  
 AUDI  
 NISSAN  
 TALBOT  
 VW



**9085**  
Zündsystem / system  
**Bosch**  
Polyester/Polyester  
5000 Ohm entstört/suppressed  
Max. Drehzahl/RPM: 6300 /min.

Verwendung für: / applicable for:  
ALFA ROMEO  
FORD  
OPEL



**9089**  
Zündsystem / system  
**Bosch**  
Polyester/Polyester  
1000 Ohm entstört/suppressed  
Max. Drehzahl/RPM: 6900 /min.

Verwendung für: / applicable for:  
VW



**9090**  
Zündsystem / system  
**Bosch**  
Polyester/Polyester  
1000 Ohm entstört/suppressed

Verwendung für: / applicable for:  
MERCEDES-BENZ  
PEUGEOT  
TALBOT



**9092**  
Zündsystem / system  
**Bosch**  
Polyester/Polyester  
1000 Ohm entstört/suppressed  
Max. Drehzahl/RPM: 5400 /min.

Verwendung für: / applicable for:  
TALBOT  
VOLVO  
VW



**9093**  
Zündsystem / system  
**Bosch**  
Polyester/Polyester  
5000 Ohm entstört/suppressed  
Max. Drehzahl/RPM: 6500 /min.

Verwendung für: / applicable for:  
AUDI  
OPEL  
VW



**9094**  
Zündsystem / system  
**Bosch**  
Polyester/Polyester  
1000 Ohm entstört/suppressed  
Max. Drehzahl/RPM: 6400 /min.

Verwendung für: / applicable for:  
BMW  
FORD  
TALBOT  
VOLVO



**9095**  
Zündsystem / system  
**Bosch**  
Polyester/Polyester  
1000 Ohm entstört/suppressed  
Max. Drehzahl/RPM: 6400 /min.

Verwendung für: / applicable for:  
BMW  
FORD  
OPEL  
VW



**9098**  
Zündsystem / system  
**Bosch**  
Polyester/Polyester  
1000 Ohm entstört/suppressed  
Max. Drehzahl/RPM: 6700 /min.

Verwendung für: / applicable for:  
ALFA ROMEO  
AUDI  
FORD  
VW



**9302**  
Zündsystem / system  
**Delco-Remy**  
Isolierstoff/Insulating material  
nicht entstört/not suppressed

Verwendung für: / applicable for:  
BEDFORD



**9317**  
Zündsystem / system  
**Delco-Remy**  
Isolierstoff/Insulating material  
nicht entstört/not suppressed

Verwendung für: / applicable for:  
OPEL  
VAUXHALL  
VOLVO



**9318**  
Zündsystem / system  
**Delco-Remy**  
Isolierstoff/Insulating material  
5000 Ohm entstört/suppressed

Verwendung für: / applicable for:  
OPEL  
VAUXHALL  
VOLVO



**9319**  
Zündsystem / system  
**Delco-Remy**  
Polypropylen/Polypropylen  
nicht entstört/not suppressed

Verwendung für: / applicable for:  
BEDFORD  
OPEL  
VAUXHALL



**9321**  
Zündsystem / system  
Delco-Remy  
Polypropylen/Polypropylen  
1000 Ohm entstört/suppressed

Verwendung für: / applicable for:  
BEDFORD  
OPEL  
VAUXHALL



**9323**  
Zündsystem / system  
Delco-Remy  
Polypropylen/Polypropylen  
nicht entstört/not suppressed

Verwendung für: / applicable for:  
BEDFORD  
OPEL  
VAUXHALL



**9324**  
Zündsystem / system  
Delco-Remy  
PBT/PBT  
nicht entstört/not suppressed

Verwendung für: / applicable for:  
DAEWOO  
HOLDEN



**9382**  
Zündsystem / system  
Ducellier  
Isolierstoff/Insulating material  
nicht entstört/not suppressed

Verwendung für: / applicable for:  
ALFA ROMEO  
AUSTIN  
AUSTIN MORRIS  
AUTOBIANCHI  
CHRYSLER  
CITROEN  
DAF  
FIAT  
HILLMANN  
INNOCENTI  
PEUGEOT  
RENAULT  
SIMCA  
TALBOT  
VOLVO



**9382P**  
Zündsystem / system  
Ducellier  
Polyester/Polyester  
nicht entstört/not suppressed

Verwendung für: / applicable for:  
AUSTIN  
AUSTIN MORRIS  
FIAT  
LAND ROVER  
MG  
PEUGEOT  
RENAULT  
ROVER  
TALBOT



**9383**  
Zündsystem / system  
Ducellier  
Isolierstoff/Insulating material  
nicht entstört/not suppressed

Verwendung für: / applicable for:  
PEUGEOT  
RENAULT



**9385**  
Zündsystem / system  
Ducellier  
Isolierstoff/Insulating material  
5000 Ohm entstört/suppressed

Verwendung für: / applicable for:  
ALFA ROMEO  
AUSTIN  
AUSTIN MORRIS  
AUTOBIANCHI  
CHRYSLER  
CITROEN  
DACIA  
DAF  
FIAT  
HILLMANN  
INNOCENTI  
LANCIA  
PEUGEOT  
RENAULT  
SEAT  
SIMCA  
TALBOT  
VOLVO



**9385P**  
Zündsystem / system  
Ducellier  
Polyester/Polyester  
5000 Ohm entstört/suppressed

Verwendung für: / applicable for:  
AUSTIN  
AUSTIN MORRIS  
FIAT  
LAND ROVER  
MG  
PEUGEOT  
RENAULT  
TALBOT



**9390**  
Zündsystem / system  
Ducellier  
Isolierstoff/Insulating material  
nicht entstört/not suppressed

Verwendung für: / applicable for:  
CITROEN  
PEUGEOT  
RENAULT  
TALBOT



**9394**  
 Zündsystem / system  
 Ducellier  
 Isolierstoff/Insulating material  
 5000 Ohm entstört/suppressed  
 Verwendung für: / applicable for:  
 CITROEN  
 FIAT  
 PEUGEOT  
 RENAULT  
 TALBOT



**9395**  
 Zündsystem / system  
 Ducellier  
 Polyester/Polyester  
 5000 Ohm entstört/suppressed  
 Verwendung für: / applicable for:  
 AUDI  
 VW



**9396**  
 Zündsystem / system  
 Ducellier  
 Isolierstoff/Insulating material  
 nicht entstört/not suppressed  
 Verwendung für: / applicable for:  
 CITROEN  
 FIAT  
 LANCIA  
 PEUGEOT  
 RENAULT  
 TALBOT



**9398**  
 Zündsystem / system  
 Ducellier  
 Polypropylen/Polypropylen  
 nicht entstört/not suppressed  
 Max. Drehzahl/RPM: 6800 /min.  
 Verwendung für: / applicable for:  
 ALFA ROMEO  
 NISSAN



**9449**  
 Zündsystem / system  
 Fensa  
 PBT/PBT  
 nicht entstört/not suppressed  
 Verwendung für: / applicable for:  
 RENAULT



**9472**  
 Zündsystem / system  
 Denso  
 Isolierstoff/Insulating material  
 nicht entstört/not suppressed  
 Verwendung für: / applicable for:  
 TOYOTA



**9474**  
 Zündsystem / system  
 Denso  
 Isolierstoff/Insulating material  
 nicht entstört/not suppressed  
 Verwendung für: / applicable for:  
 BEDFORD  
 DAIHATSU  
 HOLDEN  
 INNOCENTI  
 ISUZU  
 MITSUBISHI  
 SUBARU  
 SUZUKI  
 TOYOTA



**9475**  
 Zündsystem / system  
 Denso  
 Isolierstoff/Insulating material  
 5000 Ohm entstört/suppressed  
 Verwendung für: / applicable for:  
 BEDFORD  
 DAIHATSU  
 INNOCENTI  
 ISUZU  
 MITSUBISHI  
 SUBARU  
 SUZUKI  
 TOYOTA



**9477**  
 Zündsystem / system  
 Denso  
 Isolierstoff/Insulating material  
 5000 Ohm entstört/suppressed  
 Verwendung für: / applicable for:  
 TOYOTA



**9480**  
 Zündsystem / system  
 Denso  
 Polypropylen/Polypropylen  
 nicht entstört/not suppressed  
 Verwendung für: / applicable for:  
 BEDFORD  
 DAIHATSU  
 TOYOTA



**9482**  
 Zündsystem / system  
 Denso  
 Polypropylen/Polypropylen  
 nicht entstört/not suppressed  
 Verwendung für: / applicable for:  
 DAIHATSU  
 ISUZU  
 TOYOTA



**9483**  
Zündsystem / system  
**Denso**  
Polypropylen/Polypropylen  
nicht entstört/not suppressed  
  
Verwendung für: / applicable for:  
TOYOTA



**9484**  
Zündsystem / system  
**Denso**  
Polypropylen/Polypropylen  
nicht entstört/not suppressed  
  
Verwendung für: / applicable for:  
DAIHATSU  
HOLDEN  
ISUZU  
SUBARU  
TOYOTA



**9485**  
Zündsystem / system  
**Denso**  
Polypropylen/Polypropylen  
nicht entstört/not suppressed  
  
Verwendung für: / applicable for:  
DAIHATSU  
HOLDEN  
SUZUKI



**9486**  
Zündsystem / system  
**Denso**  
Polypropylen/Polypropylen  
nicht entstört/not suppressed  
  
Verwendung für: / applicable for:  
SUZUKI



**9487**  
Zündsystem / system  
**Denso**  
Polypropylen/Polypropylen  
nicht entstört/not suppressed  
  
Verwendung für: / applicable for:  
SUZUKI  
TOYOTA



**9488**  
Zündsystem / system  
**Denso**  
Polypropylen/Polypropylen  
nicht entstört/not suppressed  
  
Verwendung für: / applicable for:  
MAZDA



**9489**  
Zündsystem / system  
**Denso**  
Polypropylen/Polypropylen  
nicht entstört/not suppressed  
  
Verwendung für: / applicable for:  
DAIHATSU  
HOLDEN  
SUBARU  
SUZUKI



**9491**  
Zündsystem / system  
**Denso**  
Polypropylen/Polypropylen  
nicht entstört/not suppressed  
  
Verwendung für: / applicable for:  
HOLDEN  
LEXUS  
TOYOTA



**9492**  
Zündsystem / system  
**Denso**  
Polypropylen/Polypropylen  
nicht entstört/not suppressed  
  
Verwendung für: / applicable for:  
TOYOTA



**9493**  
Zündsystem / system  
**Denso**  
Polypropylen/Polypropylen  
nicht entstört/not suppressed  
  
Verwendung für: / applicable for:  
TOYOTA



**9501**  
Zündsystem / system  
**Hitachi**  
Polypropylen/Polypropylen  
nicht entstört/not suppressed  
  
Verwendung für: / applicable for:  
FORD  
HOLDEN  
HONDA  
ISUZU  
NISSAN  
SUBARU



**9502**  
Zündsystem / system  
**Hitachi**  
Polypropylen/Polypropylen  
25 Ohm entstört/suppressed  
  
Verwendung für: / applicable for:  
HONDA



**9503**  
Zündsystem / system  
**Hitachi**  
Epoxydharz/Epoxy resin  
5000 Ohm entstört/suppressed  
  
Verwendung für: / applicable for:  
HONDA  
ISUZU  
NISSAN  
SUBARU



**9504**  
Zündsystem / system  
**Hitachi**  
Polypropylen/Polypropylen  
nicht entstört/not suppressed  
  
Verwendung für: / applicable for:  
HOLDEN  
NISSAN  
SUBARU



**9506**  
Zündsystem / system  
**Hitachi**  
Epoxydharz/Epoxy resin  
nicht entstört/not suppressed  
  
Verwendung für: / applicable for:  
HONDA  
ROVER  
SUBARU  
TRIUMPH



**9507**  
Zündsystem / system  
**Hitachi**  
Epoxydharz/Epoxy resin  
5000 Ohm entstört/suppressed  
  
Verwendung für: / applicable for:  
HONDA  
ROVER  
TRIUMPH



**9508**  
Zündsystem / system  
**Hitachi**  
Epoxydharz/Epoxy resin  
5000 Ohm entstört/suppressed  
  
Verwendung für: / applicable for:  
SUBARU



**9511**  
Zündsystem / system  
**Hitachi**  
Polypropylen/Polypropylen  
nicht entstört/not suppressed  
  
Verwendung für: / applicable for:  
NISSAN



**9512**  
Zündsystem / system  
**Hitachi**  
Polypropylen/Polypropylen  
nicht entstört/not suppressed  
  
Verwendung für: / applicable for:  
HONDA



**9513**  
Zündsystem / system  
**Hitachi**  
Polypropylen/Polypropylen  
nicht entstört/not suppressed  
  
Verwendung für: / applicable for:  
HONDA  
ROVER



**9514**  
Zündsystem / system  
**Hitachi**  
Polypropylen/Polypropylen  
nicht entstört/not suppressed  
  
Verwendung für: / applicable for:  
MAZDA  
SUBARU



**9515**  
Zündsystem / system  
**Hitachi**  
Polypropylen/Polypropylen  
nicht entstört/not suppressed  
  
Verwendung für: / applicable for:  
NISSAN



**9516**  
Zündsystem / system  
**Hitachi**  
Polypropylen/Polypropylen  
nicht entstört/not suppressed  
  
Verwendung für: / applicable for:  
NISSAN



**9517**  
Zündsystem / system  
**Hitachi**  
Polypropylen/Polypropylen  
nicht entstört/not suppressed  
  
Verwendung für: / applicable for:  
NISSAN



**9519**  
Zündsystem / system  
**Hitachi**  
Polypropylen/Polypropylen  
nicht entstört/not suppressed  
  
Verwendung für: / applicable for:  
HONDA



**9521**  
Zündsystem / system  
**Hitachi**  
Polypropylen/Polypropylen  
nicht entstört/not suppressed  
  
Verwendung für: / applicable for:  
SUBARU



**9522**  
Zündsystem / system  
**Hitachi**  
Polypropylen/Polypropylen  
nicht entstört/not suppressed  
  
Verwendung für: / applicable for:  
NISSAN  
SUBARU



**9523**  
Zündsystem / system  
**Hitachi**  
Polypropylen/Polypropylen  
nicht entstört/not suppressed  
  
Verwendung für: / applicable for:  
HOLDEN  
ISUZU  
OPEL



**9524**  
Zündsystem / system  
**Hitachi**  
Polypropylen/Polypropylen  
nicht entstört/not suppressed  
  
Verwendung für: / applicable for:  
HONDA



**9528**  
Zündsystem / system  
**Mitsubishi**  
Epoxydharz/Epoxy resin  
nicht entstört/not suppressed  
  
Verwendung für: / applicable for:  
HYUNDAI  
MAZDA  
MITSUBISHI  
NISSAN



**9530**  
Zündsystem / system  
**Mitsubishi**  
Epoxydharz/Epoxy resin  
5000 Ohm entstört/suppressed  
  
Verwendung für: / applicable for:  
HYUNDAI  
MAZDA  
MITSUBISHI  
NISSAN



**9531**  
Zündsystem / system  
**Mitsubishi**  
Epoxydharz/Epoxy resin  
nicht entstört/not suppressed  
  
Verwendung für: / applicable for:  
MAZDA  
MITSUBISHI



**9534**  
Zündsystem / system  
**Mitsubishi**  
Polypropylen/Polypropylen  
nicht entstört/not suppressed  
  
Verwendung für: / applicable for:  
HYUNDAI  
MITSUBISHI



**9535**  
Zündsystem / system  
**Mitsubishi**  
Polypropylen/Polypropylen  
nicht entstört/not suppressed  
  
Verwendung für: / applicable for:  
NISSAN



**9536**  
Zündsystem / system  
**Mitsubishi**  
Polypropylen/Polypropylen  
nicht entstört/not suppressed  
  
Verwendung für: / applicable for:  
HOLDEN  
MAZDA  
SUZUKI



**9537**  
Zündsystem / system  
**Mitsubishi**  
Polypropylen/Polypropylen  
nicht entstört/not suppressed  
  
Verwendung für: / applicable for:  
MAZDA



**9538**  
 Zündsystem / system  
**Mitsubishi**  
 Polypropylen/Polypropylen  
 nicht entstört/not suppressed  
 Verwendung für: / applicable for:  
 NISSAN



**9547**  
 Zündsystem / system  
**Mitsubishi**  
 Polyester/Polyester  
 nicht entstört/not suppressed  
 Verwendung für: / applicable for:  
 NISSAN



**9539**  
 Zündsystem / system  
**Mitsubishi**  
 Polypropylen/Polypropylen  
 nicht entstört/not suppressed  
 Verwendung für: / applicable for:  
 FORD  
 KIA  
 MAZDA  
 MITSUBISHI  
 PROTON



**9548**  
 Zündsystem / system  
**Mitsubishi**  
 Polyester/Polyester  
 nicht entstört/not suppressed  
 Verwendung für: / applicable for:  
 HYUNDAI  
 KIA



**9541**  
 Zündsystem / system  
**Mitsubishi**  
 Polyester/Polyester  
 nicht entstört/not suppressed  
 Verwendung für: / applicable for:  
 MAZDA  
 MITSUBISHI



**9549**  
 Zündsystem / system  
**Mitsubishi**  
 Polypropylen/Polypropylen  
 nicht entstört/not suppressed  
 Verwendung für: / applicable for:  
 MITSUBISHI



**9543**  
 Zündsystem / system  
**Mitsubishi**  
 Polypropylen/Polypropylen  
 nicht entstört/not suppressed  
 Verwendung für: / applicable for:  
 FORD  
 HOLDEN  
 MAZDA  
 NISSAN  
 SUBARU  
 SUZUKI



**9550**  
 Zündsystem / system  
**Hitachi**  
 Polypropylen/Polypropylen  
 nicht entstört/not suppressed  
 Verwendung für: / applicable for:  
 HONDA  
 ROVER



**9545**  
 Zündsystem / system  
**Mitsubishi**  
 Polypropylen/Polypropylen  
 nicht entstört/not suppressed  
 Verwendung für: / applicable for:  
 CHRYSLER  
 HYUNDAI  
 MITSUBISHI



**9551**  
 Zündsystem / system  
**Lucas**  
**Ford**  
 Polyester/Polyester  
 nicht entstört/not suppressed  
 Verwendung für: / applicable for:  
 MITSUBISHI



**9546**  
 Zündsystem / system  
**Mitsubishi**  
 Polyester/Polyester  
 nicht entstört/not suppressed  
 Verwendung für: / applicable for:  
 MAZDA



**9556**  
 Zündsystem / system  
**Lucas**  
 Polypropylen/Polypropylen  
 1000 Ohm entstört/suppressed  
 Verwendung für: / applicable for:  
 ROVER





**9563**  
Zündsystem / system  
Lucas  
Ford  
Polyester/Polyester  
nicht entstört/not suppressed  
  
Verwendung für: / applicable for:  
FORD  
MORGAN



**9565**  
Zündsystem / system  
Lucas  
Ford  
Polyester/Polyester  
5000 Ohm entstört/suppressed  
  
Verwendung für: / applicable for:  
FORD  
MORGAN



**9567**  
Zündsystem / system  
Lucas  
Ford  
Isolierstoff/Insulating material  
nicht entstört/not suppressed  
  
Verwendung für: / applicable for:  
AUSTIN  
AUSTIN MORRIS  
HILLMANN  
INNOCENTI  
LAND ROVER  
LOTUS  
MG  
MORRIS  
RENAULT  
ROVER  
TRIUMPH  
WOLSELEY



**9571**  
Zündsystem / system  
Lucas  
Ford  
Isolierstoff/Insulating material  
1000 Ohm entstört/suppressed  
  
Verwendung für: / applicable for:  
FORD  
RENAULT



**9575**  
Zündsystem / system  
Ford  
Polypropylen/Polypropylen  
nicht entstört/not suppressed  
  
Verwendung für: / applicable for:  
FORD  
SUBARU



**9576**  
Zündsystem / system  
Lucas  
Ford  
Polypropylen/Polypropylen  
nicht entstört/not suppressed  
  
Verwendung für: / applicable for:  
AUSTIN  
AUSTIN MORRIS  
MG  
ROVER



**9577**  
Zündsystem / system  
Lucas  
Ford  
Polypropylen/Polypropylen  
1000 Ohm entstört/suppressed  
  
Verwendung für: / applicable for:  
AUSTIN  
MG  
ROVER



**9578**  
Zündsystem / system  
Lucas  
Ford  
Polyester/Polyester  
1000 Ohm entstört/suppressed  
  
Verwendung für: / applicable for:  
FORD  
LAND ROVER



**9579**  
Zündsystem / system  
Ford  
PBT/PBT  
nicht entstört/not suppressed  
  
Verwendung für: / applicable for:  
CHRYSLER  
FORD



**9580**  
Zündsystem / system  
Lucas  
Polypropylen/Polypropylen  
5000 Ohm entstört/suppressed  
  
Verwendung für: / applicable for:  
HOLDEN  
OPEL  
VAUXHALL



**9581**  
Zündsystem / system  
Ford  
Polypropylen/Polypropylen  
1000 Ohm entstört/suppressed  
  
Verwendung für: / applicable for:  
FORD



**9582**  
Zündsystem / system  
**Lucas**  
Polypropylen/Polypropylen  
nicht entstört/not suppressed  
Verwendung für: / applicable for:  
NISSAN



**9591**  
Zündsystem / system  
**Mitsubishi**  
Polypropylen/Polypropylen  
nicht entstört/not suppressed  
Verwendung für: / applicable for:  
MITSUBISHI



**9584**  
Zündsystem / system  
**Mitsubishi**  
Polypropylen/Polypropylen  
nicht entstört/not suppressed  
Verwendung für: / applicable for:  
MAZDA



**9623**  
Zündsystem / system  
**Marelli**  
Isolierstoff/Insulating material  
5000 Ohm entstört/suppressed  
Verwendung für: / applicable for:  
AUTOBIANCHI  
FIAT  
GAZ  
LADA (Shiguli)  
LANCIA  
RENAULT  
SEAT



**9585**  
Zündsystem / system  
**Lucas**  
Polypropylen/Polypropylen  
nicht entstört/not suppressed  
Verwendung für: / applicable for:  
MAZDA



**9833**  
Zündsystem / system  
**Russia**  
Polypropylen/Polypropylen  
1000 Ohm entstört/suppressed  
Verwendung für: / applicable for:  
LADA  
LADA (Shiguli)



**9586**  
Zündsystem / system  
**Hitachi**  
Polypropylen/Polypropylen  
nicht entstört/not suppressed  
Verwendung für: / applicable for:  
MAZDA



**9587**  
Zündsystem / system  
**Mitsubishi**  
Polypropylen/Polypropylen  
nicht entstört/not suppressed  
Verwendung für: / applicable for:  
MAZDA



**9590**  
Zündsystem / system  
**Mitsubishi**  
Polypropylen/Polypropylen  
nicht entstört/not suppressed  
Verwendung für: / applicable for:  
MITSUBISHI



**6001**  
Zündsystem / system  
**Bosch**  
Polyester/Polyester  
nicht entstört/not suppressed

Anschluß:  
Connector: 

Verwendung für: / applicable for:  
FORD



**6002**  
Zündsystem / system  
**Bosch**  
Polyester/Polyester  
nicht entstört/not suppressed

Anschluß:  
Connector: 

Verwendung für: / applicable for:  
VW

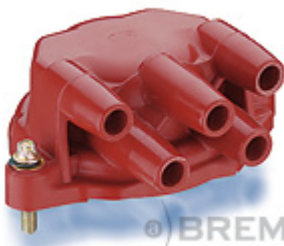

**6003**  
Zündsystem / system  
**Bosch**  
Polyester/Polyester  
nicht entstört/not suppressed

Anschluß:  
Connector: 

Verwendung für: / applicable for:  
OPEL  
VAUXHALL



**6004**  
Zündsystem / system  
**Bosch**  
Polyester/Polyester  
nicht entstört/not suppressed

Anschluß:  
Connector: 

Verwendung für: / applicable for:  
CITROEN  
PEUGEOT



**6005**  
Zündsystem / system  
**Bosch**  
Polyester/Polyester  
1000 Ohm entstört/suppressed

Anschluß:  
Connector: 

Verwendung für: / applicable for:  
MERCEDES-BENZ



**6006**  
Zündsystem / system  
**Bosch**  
Polyester/Polyester  
1000 Ohm entstört/suppressed

Anschluß:  
Connector: 

Verwendung für: / applicable for:  
MERCEDES-BENZ



**6007**  
Zündsystem / system  
**Bosch**  
Polyester/Polyester  
Haube aus leitendem Kunststoff/  
Shield of conductive material  
1000 Ohm entstört/suppressed

Anschluß:  
Connector: 

Verwendung für: / applicable for:  
MERCEDES-BENZ



**6008**  
Zündsystem / system  
**Bosch**  
Polyester/Polyester  
Haube aus leitendem Kunststoff/  
Shield of conductive material  
1000 Ohm entstört/suppressed

Anschluß:  
Connector: 

Verwendung für: / applicable for:  
PORSCHE



**6009**  
Zündsystem / system  
**Bosch**  
Polyester/Polyester  
nicht entstört/not suppressed

Anschluß:  
Connector: 

Verwendung für: / applicable for:  
FORD

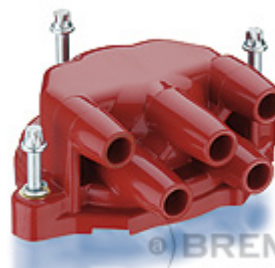

**6010**  
Zündsystem / system  
**Bosch**  
Polyester/Polyester  
nicht entstört/not suppressed

Anschluß:  
Connector: 

Verwendung für: / applicable for:  
OPEL  
VAUXHALL



**6011**  
Zündsystem / system  
**Bosch**  
Polyester/Polyester  
nicht entstört/not suppressed

Anschluß:  
Connector: 

Verwendung für: / applicable for:  
OPEL  
VAUXHALL



M4 Anschluß  
M4 connection



SAE Anschluß  
SAE connection



Rastanschluß  
Snap on connection



Buchsenanschluß  
Bush connection



SAE Rillenanschluß  
SAE-Groove connection



**6012R**  
 Zündsystem / system  
 Bosch  
 Polyester/Polyester  
 Haube aus leitendem Kunststoff/  
 Shield of conductive material  
 1000 Ohm entstört/suppressed  
 Anschluß:  
 Connector:  
 Verwendung für: / applicable for:  
 MERCEDES-BENZ  
 OPEL



**6017R**  
 Zündsystem / system  
 Bosch  
 Polyester/Polyester  
 Haube aus leitendem Kunststoff/  
 Shield of conductive material  
 1000 Ohm entstört/suppressed  
 Anschluß:  
 Connector:  
 Verwendung für: / applicable for:  
 MERCEDES-BENZ



**6013**  
 Zündsystem / system  
 Bosch  
 Polyester/Polyester  
 nicht entstört/not suppressed  
 Anschluß:  
 Connector:  
 Verwendung für: / applicable for:  
 AUDI



**6018R**  
 Zündsystem / system  
 Bosch  
 Polyester/Polyester  
 1000 Ohm entstört/suppressed  
 Anschluß:  
 Connector:  
 Verwendung für: / applicable for:  
 MERCEDES-BENZ



**6014**  
 Zündsystem / system  
 Bosch  
 Polyester/Polyester  
 nicht entstört/not suppressed  
 Anschluß:  
 Connector:  
 Verwendung für: / applicable for:  
 HOLDEN  
 OPEL  
 VAUXHALL



**6019R**  
 Zündsystem / system  
 Bosch  
 Polyester/Polyester  
 Haube aus leitendem Kunststoff/  
 Shield of conductive material  
 nicht entstört/not suppressed  
 Anschluß:  
 Connector:  
 Verwendung für: / applicable for:  
 ALFA ROMEO  
 ALPINE  
 LANCIA  
 PEUGEOT  
 RENAULT  
 VOLVO



**6015**  
 Zündsystem / system  
 Bosch  
 Polyester/Polyester  
 nicht entstört/not suppressed  
 Anschluß:  
 Connector:  
 Verwendung für: / applicable for:  
 OPEL  
 VAUXHALL



**6020**  
 Zündsystem / system  
 Bosch  
 Polyester/Polyester  
 nicht entstört/not suppressed  
 Anschluß:  
 Connector:  
 Verwendung für: / applicable for:  
 VOLVO



**6016**  
 Zündsystem / system  
 Bosch  
 Polyester/Polyester  
 nicht entstört/not suppressed  
 Anschluß:  
 Connector:  
 Verwendung für: / applicable for:  
 HOLDEN  
 OPEL  
 VAUXHALL



**6021R**  
 Zündsystem / system  
 Bosch  
 Polyester/Polyester  
 Haube aus leitendem Kunststoff/  
 Shield of conductive material  
 nicht entstört/not suppressed  
 Anschluß:  
 Connector:  
 Verwendung für: / applicable for:  
 CITROEN  
 PEUGEOT  
 RENAULT



M4 Anschluß  
 M4 connection



SAE Anschluß  
 SAE connection



Rastanschluß  
 Snap on connection



Buchsenanschluß  
 Bush connection



SAE Rillenanschluß  
 SAE-Groove connection



**6022R**  
 Zündsystem / system  
 Bosch  
 Polyester/Polyester  
 Haube aus leitendem Kunststoff/  
 Shield of conductive material  
 nicht entstört/not suppressed  
 Anschluß:  
 Connector:  
 Verwendung für: / applicable for:  
 BMW



**6023R**  
 Zündsystem / system  
 Bosch  
 Polyester/Polyester  
 Haube aus leitendem Kunststoff/  
 Shield of conductive material  
 1000 Ohm entstört/suppressed  
 Anschluß:  
 Connector:  
 Verwendung für: / applicable for:  
 PORSCHE



**6027**  
 Zündsystem / system  
 Bosch  
 Polyester/Polyester  
 nicht entstört/not suppressed  
 Anschluß:  
 Connector:  
 Verwendung für: / applicable for:  
 SEAT  
 SKODA  
 VW



**6027R**  
 Zündsystem / system  
 Bosch  
 Polyester/Polyester  
 Haube aus leitendem Kunststoff/  
 Shield of conductive material  
 nicht entstört/not suppressed  
 Anschluß:  
 Connector:  
 Verwendung für: / applicable for:  
 AUDI  
 SEAT  
 VW



**6028R**  
 Zündsystem / system  
 Bosch  
 Polyester/Polyester  
 Haube aus leitendem Kunststoff/  
 Shield of conductive material  
 1000 Ohm entstört/suppressed  
 Anschluß:  
 Connector:  
 Verwendung für: / applicable for:  
 MERCEDES-BENZ



**6029**  
 Zündsystem / system  
 Bosch  
 Polyester/Polyester  
 nicht entstört/not suppressed  
 Anschluß:  
 Connector:  
 Verwendung für: / applicable for:  
 SEAT  
 VW



**6300**  
 Zündsystem / system  
 Ducellier  
 Polyester/Polyester  
 nicht entstört/not suppressed  
 Anschluß:  
 Connector:  
 Verwendung für: / applicable for:  
 RENAULT  
 VOLVO



**6301**  
 Zündsystem / system  
 Ducellier  
 Polyester/Polyester  
 nicht entstört/not suppressed  
 Anschluß:  
 Connector:  
 Verwendung für: / applicable for:  
 RENAULT



**6302**  
 Zündsystem / system  
 Ducellier  
 Polyester/Polyester  
 nicht entstört/not suppressed  
 Anschluß:  
 Connector:  
 Verwendung für: / applicable for:  
 CITROEN  
 PEUGEOT  
 RENAULT



**6303**  
 Zündsystem / system  
 Ducellier  
 Polypropylen/Polypropylen  
 nicht entstört/not suppressed  
 Anschluß:  
 Connector:  
 Verwendung für: / applicable for:  
 RENAULT  
 VOLVO



M4 Anschluß  
 M4 connection



SAE Anschluß  
 SAE connection



Rastanschluß  
 Snap on connection



Buchsenanschluß  
 Bush connection



SAE Rillenanschluß  
 SAE-Groove connection



**6304**  
 Zündsystem / system  
 Ducellier  
 Polyester/Polyester  
 nicht entstört/not suppressed  
 Anschluß:  
 Connector:  
 Verwendung für: / applicable for:  
 AUDI  
 SEAT  
 VW



**6309**  
 Zündsystem / system  
 Ducellier  
 Polypropylen/Polypropylen  
 nicht entstört/not suppressed  
 Anschluß:  
 Connector:  
 Verwendung für: / applicable for:  
 RENAULT



**6305**  
 Zündsystem / system  
 Ducellier  
 Polypropylen/Polypropylen  
 nicht entstört/not suppressed  
 Anschluß:  
 Connector:  
 Verwendung für: / applicable for:  
 CITROEN  
 FIAT  
 LANCIA  
 PEUGEOT



**6310**  
 Zündsystem / system  
 Ducellier  
 Polypropylen/Polypropylen  
 nicht entstört/not suppressed  
 Anschluß:  
 Connector:  
 Verwendung für: / applicable for:  
 RENAULT



**6306**  
 Zündsystem / system  
 Ducellier  
 Polypropylen/Polypropylen  
 nicht entstört/not suppressed  
 Anschluß:  
 Connector:  
 Verwendung für: / applicable for:  
 CITROEN  
 PEUGEOT  
 RENAULT



**6402**  
 Zündsystem / system  
 Denso  
 Polypropylen/Polypropylen  
 nicht entstört/not suppressed  
 Anschluß:  
 Connector:  
 Verwendung für: / applicable for:  
 MITSUBISHI



**6307**  
 Zündsystem / system  
 Ducellier  
 Polyester/Polyester  
 nicht entstört/not suppressed  
 Anschluß:  
 Connector:  
 Verwendung für: / applicable for:  
 RENAULT



**6404**  
 Zündsystem / system  
 Denso  
 Polypropylen/Polypropylen  
 nicht entstört/not suppressed  
 Anschluß:  
 Connector:  
 Verwendung für: / applicable for:  
 TOYOTA



**6308**  
 Zündsystem / system  
 Ducellier  
 Polypropylen/Polypropylen  
 nicht entstört/not suppressed  
 Anschluß:  
 Connector:  
 Verwendung für: / applicable for:  
 RENAULT



**6405**  
 Zündsystem / system  
 Denso  
 Polypropylen/Polypropylen  
 nicht entstört/not suppressed  
 Anschluß:  
 Connector:  
 Verwendung für: / applicable for:  
 HOLDEN  
 TOYOTA



**6406**  
 Zündsystem / system  
 Denso  
 Polypropylen/Polypropylen  
 nicht entstört/not suppressed  
 Anschluß:  
 Connector:  
 Verwendung für: / applicable for:  
 SUZUKI



M4 Anschluß  
 M4 connection



SAE Anschluß  
 SAE connection



Rastanschluß  
 Snap on connection



Buchsenanschluß  
 Bush connection



SAE Rillenanschluß  
 SAE-Groove connection



**6407**  
 Zündsystem / system  
 Denso  
 Polypropylen/Polypropylen  
 nicht entstört/not suppressed  
 Anschluß:  
 Connector:  
 Verwendung für: / applicable for:  
 DAIHATSU



**6408**  
 Zündsystem / system  
 Denso  
 Polypropylen/Polypropylen  
 nicht entstört/not suppressed  
 Anschluß:  
 Connector:  
 Verwendung für: / applicable for:  
 DAIHATSU



**6409**  
 Zündsystem / system  
 Denso  
 Polypropylen/Polypropylen  
 nicht entstört/not suppressed  
 Anschluß:  
 Connector:  
 Verwendung für: / applicable for:  
 SUBARU



**6410**  
 Zündsystem / system  
 Denso  
 Polypropylen/Polypropylen  
 nicht entstört/not suppressed  
 Anschluß:  
 Connector:  
 Verwendung für: / applicable for:  
 DAIHATSU  
 TOYOTA



**6412**  
 Zündsystem / system  
 Bosch  
 Polypropylen/Polypropylen  
 nicht entstört/not suppressed  
 Anschluß:  
 Connector:  
 Verwendung für: / applicable for:  
 TOYOTA



**6413**  
 Zündsystem / system  
 Denso  
 Polypropylen/Polypropylen  
 nicht entstört/not suppressed  
 Anschluß:  
 Connector:  
 Verwendung für: / applicable for:  
 TOYOTA



**6414**  
 Zündsystem / system  
 Denso  
 Polypropylen/Polypropylen  
 15000 Ohm entstört/suppressed  
 Anschluß:  
 Connector:  
 Verwendung für: / applicable for:  
 TOYOTA



**6415**  
 Zündsystem / system  
 Denso  
 Polypropylen/Polypropylen  
 nicht entstört/not suppressed  
 Anschluß:  
 Connector:  
 Verwendung für: / applicable for:  
 TOYOTA



**6416**  
 Zündsystem / system  
 Denso  
 PBT/PBT  
 nicht entstört/not suppressed  
 Anschluß:  
 Connector:  
 Verwendung für: / applicable for:  
 TOYOTA



**6417**  
 Zündsystem / system  
 Denso  
 PBT/PBT  
 nicht entstört/not suppressed  
 Anschluß:  
 Connector:  
 Verwendung für: / applicable for:  
 HOLDEN  
 LEXUS  
 TOYOTA



**6418**  
 Zündsystem / system  
 Denso  
 Polypropylen/Polypropylen  
 15000 Ohm entstört/suppressed  
 Anschluß:  
 Connector:  
 Verwendung für: / applicable for:  
 HOLDEN  
 TOYOTA



**6420**  
 Zündsystem / system  
 Denso  
 Polypropylen/Polypropylen  
 15000 Ohm entstört/suppressed  
 Anschluß:  
 Connector:  
 Verwendung für: / applicable for:  
 HOLDEN  
 TOYOTA



M4 Anschluß  
 M4 connection



SAE Anschluß  
 SAE connection



Rastanschluß  
 Snap on connection



Buchsenanschluß  
 Bush connection



SAE Rillenanschluß  
 SAE-Groove connection



**6421**  
Zündsystem / system  
Denso  
Polypropylen/Polypropylen  
15000 Ohm entstört/suppressed  
Anschluß:  
Connector:  
Verwendung für: / applicable for:  
HOLDEN  
TOYOTA



**6428**  
Zündsystem / system  
Denso  
Polypropylen/Polypropylen  
15000 Ohm entstört/suppressed  
Anschluß:  
Connector:  
Verwendung für: / applicable for:  
TOYOTA



**6422**  
Zündsystem / system  
Valeo  
Polyester/Polyester  
nicht entstört/not suppressed  
Anschluß:  
Connector:  
Verwendung für: / applicable for:  
OPEL  
VAUXHALL



**6502**  
Zündsystem / system  
Hitachi  
Polypropylen/Polypropylen  
nicht entstört/not suppressed  
Anschluß:  
Connector:  
Verwendung für: / applicable for:  
HONDA



**6423**  
Zündsystem / system  
Denso  
Polypropylen/Polypropylen  
nicht entstört/not suppressed  
Verwendung für: / applicable for:  
TOYOTA



**6503**  
Zündsystem / system  
Hitachi  
Polypropylen/Polypropylen  
nicht entstört/not suppressed  
Anschluß:  
Connector:  
Verwendung für: / applicable for:  
HONDA



**6424**  
Zündsystem / system  
Denso  
Polypropylen/Polypropylen  
nicht entstört/not suppressed  
Verwendung für: / applicable for:  
TOYOTA



**6505**  
Zündsystem / system  
Hitachi  
Polypropylen/Polypropylen  
nicht entstört/not suppressed  
Anschluß:  
Connector:  
Verwendung für: / applicable for:  
HONDA



**6425**  
Zündsystem / system  
Denso  
Polypropylen/Polypropylen  
nicht entstört/not suppressed  
Verwendung für: / applicable for:  
TOYOTA



**6506**  
Zündsystem / system  
Hitachi  
Polypropylen/Polypropylen  
nicht entstört/not suppressed  
Anschluß:  
Connector:  
Verwendung für: / applicable for:  
HONDA  
ROVER



**6427**  
Zündsystem / system  
Denso  
Polypropylen/Polypropylen  
15000 Ohm entstört/suppressed  
Anschluß:  
Connector:  
Verwendung für: / applicable for:  
TOYOTA



**6507**  
Zündsystem / system  
Hitachi  
Polypropylen/Polypropylen  
nicht entstört/not suppressed  
Anschluß:  
Connector:  
Verwendung für: / applicable for:  
HONDA



M4 Anschluß  
M4 connection



SAE Anschluß  
SAE connection



Rastanschluß  
Snap on connection



Buchsenanschluß  
Bush connection



SAE Rillenanschluß  
SAE-Groove connection





**6508**  
 Zündsystem / system  
 Hitachi  
 Polypropylen/Polypropylen  
 nicht entstört/not suppressed  
 Anschluß:  
 Connector:  
 Verwendung für: / applicable for:  
 SUBARU



**6509**  
 Zündsystem / system  
 Hitachi  
 Polypropylen/Polypropylen  
 nicht entstört/not suppressed  
 Anschluß:  
 Connector:  
 Verwendung für: / applicable for:  
 SUBARU



**6510**  
 Zündsystem / system  
 Hitachi  
 Polypropylen/Polypropylen  
 5000 Ohm entstört/suppressed  
 Anschluß:  
 Connector:  
 Verwendung für: / applicable for:  
 HONDA  
 ROVER



**6512**  
 Zündsystem / system  
 Hitachi  
 Polypropylen/Polypropylen  
 nicht entstört/not suppressed  
 Anschluß:  
 Connector:  
 Verwendung für: / applicable for:  
 NISSAN



**6513**  
 Zündsystem / system  
 Hitachi  
 Polypropylen/Polypropylen  
 nicht entstört/not suppressed  
 Anschluß:  
 Connector:  
 Verwendung für: / applicable for:  
 HOLDEN  
 ISUZU  
 OPEL



**6517**  
 Zündsystem / system  
 Hitachi  
 Polypropylen/Polypropylen  
 nicht entstört/not suppressed  
 Anschluß:  
 Connector:  
 Verwendung für: / applicable for:  
 SUBARU



**6520**  
 Zündsystem / system  
 Hitachi  
 Polypropylen/Polypropylen  
 nicht entstört/not suppressed  
 Anschluß:  
 Connector:  
 Verwendung für: / applicable for:  
 HONDA



**6521**  
 Zündsystem / system  
 Hitachi  
 Polypropylen/Polypropylen  
 nicht entstört/not suppressed  
 Anschluß:  
 Connector:  
 Verwendung für: / applicable for:  
 NISSAN



**6522**  
 Zündsystem / system  
 Hitachi  
 Polypropylen/Polypropylen  
 nicht entstört/not suppressed  
 Anschluß:  
 Connector:  
 Verwendung für: / applicable for:  
 NISSAN



**6523**  
 Zündsystem / system  
 Hitachi  
 Polypropylen/Polypropylen  
 nicht entstört/not suppressed  
 Anschluß:  
 Connector:  
 Verwendung für: / applicable for:  
 HONDA



**6524**  
 Zündsystem / system  
 Mitsubishi  
 Polypropylen/Polypropylen  
 10000 Ohm entstört/suppressed  
 Anschluß:  
 Connector:  
 Verwendung für: / applicable for:  
 MAZDA



**6550**  
 Zündsystem / system  
 Lucas  
 Ford  
 Polypropylen/Polypropylen  
 nicht entstört/not suppressed  
 Anschluß:  
 Connector:  
 Verwendung für: / applicable for:  
 AUSTIN  
 MG  
 ROVER



M4 Anschluß  
 M4 connection



SAE Anschluß  
 SAE connection



Rastanschluß  
 Snap on connection



Buchsenanschluß  
 Bush connection



SAE Rillenanschluß  
 SAE-Groove connection



**6552**  
 Zündsystem / system  
 Lucas  
 Ford  
 Polyester/Polyester  
 nicht entstört/not suppressed

Anschluß:  
 Connector:  
 Verwendung für: / applicable for:  
 AUSTIN  
 AUSTIN MORRIS  
 FORD  
 LAND ROVER  
 MG  
 ROVER



**6553**  
 Zündsystem / system  
 Ford  
 Polypropylen/Polypropylen  
 nicht entstört/not suppressed

Anschluß:  
 Connector:  
 Verwendung für: / applicable for:  
 CHRYSLER  
 FORD



**6554**  
 Zündsystem / system  
 Lucas  
 Ford  
 Polypropylen/Polypropylen  
 nicht entstört/not suppressed

Anschluß:  
 Connector:  
 Verwendung für: / applicable for:  
 OPEL



**6555**  
 Zündsystem / system  
 Lucas  
 Ford  
 Polyester/Polyester  
 nicht entstört/not suppressed

Anschluß:  
 Connector:  
 Verwendung für: / applicable for:  
 HOLDEN  
 OPEL  
 VAUXHALL



**6556**  
 Zündsystem / system  
 Ford  
 Polyester/Polyester  
 nicht entstört/not suppressed

Anschluß:  
 Connector:  
 Verwendung für: / applicable for:  
 FORD



**6557**  
 Zündsystem / system  
 Ford  
 Polyester/Polyester  
 nicht entstört/not suppressed

Anschluß:  
 Connector:  
 Verwendung für: / applicable for:  
 FORD



**6558**  
 Zündsystem / system  
 Lucas  
 Polypropylen/Polypropylen  
 nicht entstört/not suppressed

Anschluß:  
 Connector:  
 Verwendung für: / applicable for:  
 HONDA  
 NISSAN



**6560**  
 Zündsystem / system  
 Lucas  
 Polypropylen/Polypropylen  
 nicht entstört/not suppressed

Anschluß:  
 Connector:  
 Verwendung für: / applicable for:  
 LAND ROVER  
 MORGAN



**6602**  
 Zündsystem / system  
 Fems  
 Marelli  
 Isolierstoff/Insulating material  
 nicht entstört/not suppressed

Anschluß:  
 Connector:  
 Verwendung für: / applicable for:  
 FIAT  
 SEAT



**6603**  
 Zündsystem / system  
 Marelli  
 Isolierstoff/Insulating material  
 nicht entstört/not suppressed

Anschluß:  
 Connector:  
 Verwendung für: / applicable for:  
 FIAT



M4 Anschluß  
 M4 connection



SAE Anschluß  
 SAE connection



Rastanschluß  
 Snap on connection



Buchsenanschluß  
 Bush connection



SAE Rillenanschluß  
 SAE-Groove connection



**6604**  
 Zündsystem / system  
**Marelli**  
 Isolierstoff/Insulating material  
 nicht entstört/not suppressed  
 Anschluß:  
 Connector:  
 Verwendung für: / applicable for:  
 LADA  
 LADA (Shiguli)  
 ZAZ



**6617**  
 Zündsystem / system  
**Marelli**  
 Isolierstoff/Insulating material  
 nicht entstört/not suppressed  
 Anschluß:  
 Connector:  
 Verwendung für: / applicable for:  
 AUTOBIANCHI  
 FIAT  
 LANCIA



**6608**  
 Zündsystem / system  
**Marelli**  
 Isolierstoff/Insulating material  
 nicht entstört/not suppressed  
 Anschluß:  
 Connector:  
 Verwendung für: / applicable for:  
 ALFA ROMEO  
 CITROEN  
 FIAT  
 LANCIA  
 NISSAN



**6618**  
 Zündsystem / system  
**Marelli**  
 Isolierstoff/Insulating material  
 nicht entstört/not suppressed  
 Anschluß:  
 Connector:  
 Verwendung für: / applicable for:  
 ALFA ROMEO



**6610**  
 Zündsystem / system  
**Femsa**  
**Marelli**  
 Isolierstoff/Insulating material  
 nicht entstört/not suppressed  
 Anschluß:  
 Connector:  
 Verwendung für: / applicable for:  
 SEAT



**6624**  
 Zündsystem / system  
**Marelli**  
 Polyester/Polyester  
 nicht entstört/not suppressed  
 Anschluß:  
 Connector:  
 Verwendung für: / applicable for:  
 ALFA ROMEO  
 AUTOBIANCHI  
 FIAT  
 INNOCENTI  
 LANCIA  
 PEUGEOT  
 RENAULT  
 SEAT  
 ZASTAVA



**6612**  
 Zündsystem / system  
**Marelli**  
 Isolierstoff/Insulating material  
 nicht entstört/not suppressed  
 Anschluß:  
 Connector:  
 Verwendung für: / applicable for:  
 AUTOBIANCHI  
 FIAT  
 SEAT



**6625**  
 Zündsystem / system  
**Marelli**  
 PBT/PBT  
 nicht entstört/not suppressed  
 Anschluß:  
 Connector:  
 Verwendung für: / applicable for:  
 AUTOBIANCHI  
 FIAT  
 LANCIA



**6614**  
 Zündsystem / system  
**Marelli**  
 Polyester/Polyester  
 nicht entstört/not suppressed  
 Anschluß:  
 Connector:  
 Verwendung für: / applicable for:  
 AUTOBIANCHI  
 FIAT  
 FORD  
 LANCIA  
 PEUGEOT  
 RENAULT  
 SEAT



**6626**  
 Zündsystem / system  
**Marelli**  
 Isolierstoff/Insulating material  
 nicht entstört/not suppressed  
 Anschluß:  
 Connector:  
 Verwendung für: / applicable for:  
 FIAT



M4 Anschluß  
 M4 connection



SAE Anschluß  
 SAE connection



Rastanschluß  
 Snap on connection



Buchsenanschluß  
 Bush connection



SAE Rillenanschluß  
 SAE-Groove connection



**6627**  
Zündsystem / system  
**Marelli**  
PBT/PBT  
nicht entstört/not suppressed

Anschluß:  
Connector:   
Verwendung für: / applicable for:  
RENAULT



**6628**  
Zündsystem / system  
**Marelli**  
PBT/PBT  
nicht entstört/not suppressed

Anschluß:  
Connector:   
Verwendung für: / applicable for:  
PEUGEOT



**6629**  
Zündsystem / system  
**Femsa**  
Polypropylen/Polypropylen  
nicht entstört/not suppressed

Anschluß:  
Connector:   
Verwendung für: / applicable for:  
SEAT



**6630**  
Zündsystem / system  
**Marelli**  
Polyester/Polyester  
nicht entstört/not suppressed

Anschluß:  
Connector:   
Verwendung für: / applicable for:  
SEAT  
SKODA  
VW



**6702**  
Zündsystem / system  
**Chrysler**  
Polypropylen/Polypropylen  
nicht entstört/not suppressed

Anschluß:  
Connector:   
Verwendung für: / applicable for:  
CHRYSLER



**8002R**  
Zündsystem / system  
**Bosch**  
Polyester/Polyester  
Haube aus leitendem Kunststoff/  
Shield of conductive material  
nicht entstört/not suppressed

Anschluß:  
Connector:   
Verwendung für: / applicable for:  
BMW



**8016**  
Zündsystem / system

Anschluß:  
Connector:   
Verwendung für: / applicable for:  
BMW



**8016P**  
Zündsystem / system

Polyester/Polyester

Anschluß:  
Connector:   
Verwendung für: / applicable for:  
ALFA ROMEO  
BMW  
BORGWARD  
MERCEDES-BENZ  
OPEL  
PORSCHE  
VOLVO



**8045**  
Zündsystem / system  
**Bosch**  
Polyester/Polyester  
nicht entstört/not suppressed

Anschluß:  
Connector:   
Verwendung für: / applicable for:  
ALFA ROMEO  
AUDI  
BEDFORD  
BMW  
FIAT  
FORD  
MERCEDES-BENZ  
NISSAN  
PEUGEOT  
PORSCHE  
RENAULT  
SAAB  
SEAT  
TALBOT  
VAUXHALL  
VOLVO  
VW  
ZASTAVA



**8046**  
Zündsystem / system  
**Bosch**  
Polyester/Polyester

Anschluß:  
Connector:   
Verwendung für: / applicable for:  
FORD  
MERCEDES-BENZ



M4 Anschluß  
M4 connection



SAE Anschluß  
SAE connection



Rastanschluß  
Snap on connection



Buchsenanschluß  
Bush connection



SAE Rillenanschluß  
SAE-Groove connection



**8048**  
 Zündsystem / system  
**Bosch**  
 Polyester/Polyester  
 nicht entstört/not suppressed

Anschluß:  
 Connector:  
 Verwendung für: / applicable for:  
 ALFA ROMEO  
 BMW  
 FORD  
 PEUGEOT  
 PORSCHE



**8054**  
 Zündsystem / system  
**Bosch**  
 Polyester/Polyester  
 1000 Ohm entstört/suppressed

Anschluß:  
 Connector:  
 Verwendung für: / applicable for:  
 MERCEDES-BENZ



**8049**  
 Zündsystem / system  
**Bosch**  
 Polyester/Polyester  
 nicht entstört/not suppressed

Anschluß:  
 Connector:  
 Verwendung für: / applicable for:  
 BEDFORD  
 HOLDEN  
 OPEL  
 VAUXHALL



**8056**  
 Zündsystem / system  
**Bosch**  
 Polyester/Polyester  
 Haube aus leitendem Kunststoff/  
 Shield of conductive material  
 nicht entstört/not suppressed

Anschluß:  
 Connector:  
 Verwendung für: / applicable for:  
 BMW



**8049R**  
 Zündsystem / system  
**Bosch**  
 Polyester/Polyester  
 Haube aus leitendem Kunststoff/  
 Shield of conductive material  
 nicht entstört/not suppressed

Anschluß:  
 Connector:  
 Verwendung für: / applicable for:  
 OPEL



**8056E**  
 Zündsystem / system  
**Bosch**  
 Epoxydharz/Epoxy resin  
 nicht entstört/not suppressed

Anschluß:  
 Connector:  
 Verwendung für: / applicable for:  
 BMW



**8052**  
 Zündsystem / system  
**Bosch**  
 Polyester/Polyester  
 nicht entstört/not suppressed

Anschluß:  
 Connector:  
 Verwendung für: / applicable for:  
 FORD  
 OPEL  
 VAUXHALL



**8057**  
 Zündsystem / system  
**Bosch**  
 Polyester/Polyester  
 nicht entstört/not suppressed

Anschluß:  
 Connector:  
 Verwendung für: / applicable for:  
 AUDI  
 VW



**8052A**  
 Zündsystem / system  
**Bosch**  
 Polyester/Polyester  
 Haube: nicht leitender Kunststoff/  
 Shield of nonconductive material  
 nicht entstört/not suppressed

Anschluß:  
 Connector:  
 Verwendung für: / applicable for:  
 OPEL  
 VAUXHALL



**8058**  
 Zündsystem / system  
**Bosch**  
 Polyester/Polyester  
 nicht entstört/not suppressed

Anschluß:  
 Connector:  
 Verwendung für: / applicable for:  
 LANCIA  
 MASERATI  
 PEUGEOT  
 RENAULT  
 TALBOT  
 VOLVO  
 VW



M4 Anschluß  
 M4 connection



SAE Anschluß  
 SAE connection



Rastanschluß  
 Snap on connection



Buchsenanschluß  
 Bush connection



SAE Rillenanschluß  
 SAE-Groove connection



**8059**  
 Zündsystem / system  
 Bosch  
 Polyester/Polyester  
 nicht entstört/not suppressed

Anschluß:  
 Connector:  
 Verwendung für: / applicable for:  
 AUDI  
 BMW  
 NISSAN  
 SEAT  
 VW  
 WARTBURG



**8063**  
 Zündsystem / system  
 Bosch  
 Polyester/Polyester  
 1000 Ohm entstört/suppressed

Anschluß:  
 Connector:  
 Verwendung für: / applicable for:  
 MERCEDES-BENZ



**8059R**  
 Zündsystem / system  
 Bosch  
 Polyester/Polyester  
 Haube aus leitendem Kunststoff/  
 Shield of conductive material  
 nicht entstört/not suppressed

Anschluß:  
 Connector:  
 Verwendung für: / applicable for:  
 AUDI  
 SEAT  
 VW



**8064**  
 Zündsystem / system  
 Bosch  
 Polyester/Polyester  
 nicht entstört/not suppressed

Anschluß:  
 Connector:  
 Verwendung für: / applicable for:  
 FORD



**8060**  
 Zündsystem / system  
 Bosch  
 Polyester/Polyester  
 Haube aus leitendem Kunststoff/  
 Shield of conductive material  
 1000 Ohm entstört/suppressed

Anschluß:  
 Connector:  
 Verwendung für: / applicable for:  
 MERCEDES-BENZ



**8065**  
 Zündsystem / system  
 Bosch  
 Polyester/Polyester  
 nicht entstört/not suppressed

Anschluß:  
 Connector:  
 Verwendung für: / applicable for:  
 FORD



**8066**  
 Zündsystem / system  
 Bosch  
 Polyester/Polyester  
 nicht entstört/not suppressed

Anschluß:  
 Connector:  
 Verwendung für: / applicable for:  
 FIAT  
 LANCIA



**8062**  
 Zündsystem / system  
 Bosch  
 Epoxyharz/Epoxy resin  
 Haube aus leitendem Kunststoff/  
 Shield of conductive material  
 nicht entstört/not suppressed

Anschluß:  
 Connector:  
 Verwendung für: / applicable for:  
 BMW



**8067**  
 Zündsystem / system  
 Bosch  
 Polyester/Polyester  
 Haube aus leitendem Kunststoff/  
 Shield of conductive material  
 1000 Ohm entstört/suppressed

Anschluß:  
 Connector:  
 Verwendung für: / applicable for:  
 MERCEDES-BENZ



**8062/10**  
 Zündsystem / system  
 Bosch  
 Verwendung für: / applicable for:  
 BMW



**8068**  
 Zündsystem / system  
 Bosch  
 Polyester/Polyester  
 1000 Ohm entstört/suppressed

Anschluß:  
 Connector:  
 Verwendung für: / applicable for:  
 MERCEDES-BENZ



M4 Anschluß  
 M4 connection



SAE Anschluß  
 SAE connection



Rastanschluß  
 Snap on connection



Buchsenanschluß  
 Bush connection



SAE Rillenanschluß  
 SAE-Groove connection



**8069R**  
 Zündsystem / system  
**Bosch**  
 Polyester/Polyester  
 Haube aus leitendem Kunststoff/  
 Shield of conductive material  
 nicht entstört/not suppressed  
 Anschluß:  
 Connector:  
 Verwendung für: / applicable for:  
 BMW  
 ROLLS-ROYCE  
 VOLVO



**8073R**  
 Zündsystem / system  
**Bosch**  
 Polyester/Polyester  
 Haube: nicht leitender Kunststoff/  
 Shield of nonconductive material  
 nicht entstört/not suppressed  
 Anschluß:  
 Connector:  
 Verwendung für: / applicable for:  
 AUDI  
 NISSAN  
 VOLVO  
 VW



**8070**  
 Zündsystem / system  
**Bosch**  
 Polyester/Polyester  
 nicht entstört/not suppressed  
 Anschluß:  
 Connector:  
 Verwendung für: / applicable for:  
 CITROEN  
 HYUNDAI  
 PEUGEOT  
 SAAB  
 TALBOT



**8074R**  
 Zündsystem / system  
**Bosch**  
 Polyester/Polyester  
 Haube aus leitendem Kunststoff/  
 Shield of conductive material  
 nicht entstört/not suppressed  
 Anschluß:  
 Connector:  
 Verwendung für: / applicable for:  
 PORSCHE  
 VOLVO



**8071**  
 Zündsystem / system  
**Bosch**  
 Polyester/Polyester  
 Haube aus leitendem Kunststoff/  
 Shield of conductive material  
 1000 Ohm entstört/suppressed  
 Anschluß:  
 Connector:  
 Verwendung für: / applicable for:  
 MERCEDES-BENZ



**8077**  
 Zündsystem / system  
**PAL**  
 Isolierstoff/Insulating material  
 nicht entstört/not suppressed  
 Anschluß:  
 Connector:  
 Verwendung für: / applicable for:  
 SKODA



**8073**  
 Zündsystem / system  
**Bosch**  
 Polyester/Polyester  
 Haube: nicht leitender Kunststoff/  
 Shield of nonconductive material  
 nicht entstört/not suppressed  
 Anschluß:  
 Connector:  
 Verwendung für: / applicable for:  
 AUDI



**8078**  
 Zündsystem / system  
**PAL**  
 Isolierstoff/Insulating material  
 nicht entstört/not suppressed  
 Anschluß:  
 Connector:  
 Verwendung für: / applicable for:  
 SKODA



**8310**  
 Zündsystem / system  
**Delco-Remy**  
 Isolierstoff/Insulating material  
 nicht entstört/not suppressed  
 Anschluß:  
 Connector:  
 Verwendung für: / applicable for:  
 BEDFORD



M4 Anschluß  
 M4 connection



SAE Anschluß  
 SAE connection



Rastanschluß  
 Snap on connection



Buchsenanschluß  
 Bush connection



SAE Rillenanschluß  
 SAE-Groove connection



**8324H**  
 Zündsystem / system  
 Delco-Remy  
 Isolierstoff/Insulating material  
 nicht entstört/not suppressed  
 Anschluß:  
 Connector:  
 Verwendung für: / applicable for:  
 OPEL  
 VAUXHALL  
 VOLVO



**8325**  
 Zündsystem / system  
 Delco-Remy  
 Isolierstoff/Insulating material  
 nicht entstört/not suppressed  
 Anschluß:  
 Connector:  
 Verwendung für: / applicable for:  
 NISSAN  
 TRIUMPH



**8327**  
 Zündsystem / system  
 Delco-Remy  
 Polypropylen/Polypropylen  
 nicht entstört/not suppressed  
 Anschluß:  
 Connector:  
 Verwendung für: / applicable for:  
 BEDFORD  
 OPEL  
 VAUXHALL



**8328**  
 Zündsystem / system  
 Delco-Remy  
 Polypropylen/Polypropylen  
 nicht entstört/not suppressed  
 Anschluß:  
 Connector:  
 Verwendung für: / applicable for:  
 BEDFORD  
 OPEL  
 VAUXHALL



**8329**  
 Zündsystem / system  
 Delco-Remy  
 Polypropylen/Polypropylen  
 nicht entstört/not suppressed  
 Anschluß:  
 Connector:  
 Verwendung für: / applicable for:  
 DAEWOO  
 HOLDEN



**8385P**  
 Zündsystem / system  
 Ducellier  
 Polyester/Polyester  
 nicht entstört/not suppressed  
 Anschluß:  
 Connector:  
 Verwendung für: / applicable for:  
 ALFA ROMEO  
 AUSTIN  
 AUSTIN MORRIS  
 CITROEN  
 DACIA  
 DAF  
 FIAT  
 HILLMANN  
 MG  
 NISSAN  
 PEUGEOT  
 RENAULT  
 VOLVO



**8392**  
 Zündsystem / system  
 Ducellier  
 Isolierstoff/Insulating material  
 nicht entstört/not suppressed  
 Anschluß:  
 Connector:  
 Verwendung für: / applicable for:  
 CITROEN  
 RENAULT



**8393P**  
 Zündsystem / system  
 Ducellier  
 Polyester/Polyester  
 nicht entstört/not suppressed  
 Anschluß:  
 Connector:  
 Verwendung für: / applicable for:  
 CITROEN  
 FIAT  
 RENAULT  
 VOLVO



**8396**  
 Zündsystem / system  
 Ducellier  
 Polyester/Polyester  
 nicht entstört/not suppressed  
 Anschluß:  
 Connector:  
 Verwendung für: / applicable for:  
 AUDI  
 SEAT  
 VW



M4 Anschluß  
 M4 connection



SAE Anschluß  
 SAE connection



Rastanschluß  
 Snap on connection



Buchsenanschluß  
 Bush connection



SAE Rillenanschluß  
 SAE-Groove connection





**8397**  
 Zündsystem / system  
 Ducellier  
 Polyester/Polyester  
 nicht entstört/not suppressed

Anschluß:  
 Connector:  
 Verwendung für: / applicable for:  
 ALFA ROMEO  
 FIAT  
 LAND ROVER  
 PEUGEOT  
 RENAULT  
 TALBOT



**8398**  
 Zündsystem / system  
 Ducellier  
 Polyester/Polyester  
 nicht entstört/not suppressed

Anschluß:  
 Connector:  
 Verwendung für: / applicable for:  
 AUTOBIANCHI  
 CITROEN  
 FIAT  
 INNOCENTI  
 LANCIA  
 PEUGEOT  
 RENAULT  
 SEAT  
 TALBOT



**8453**  
 Zündsystem / system  
 Fensa  
 Polyester/Polyester  
 nicht entstört/not suppressed

Anschluß:  
 Connector:  
 Verwendung für: / applicable for:  
 RENAULT



**8471**  
 Zündsystem / system  
 Denso  
 Polypropylen/Polypropylen  
 nicht entstört/not suppressed

Anschluß:  
 Connector:  
 Verwendung für: / applicable for:  
 TOYOTA



**8473**  
 Zündsystem / system  
 Denso  
 Isolierstoff/Insulating material  
 nicht entstört/not suppressed

Anschluß:  
 Connector:  
 Verwendung für: / applicable for:  
 BEDFORD  
 ISUZU  
 TOYOTA



**8475**  
 Zündsystem / system  
 Denso  
 Isolierstoff/Insulating material  
 nicht entstört/not suppressed

Anschluß:  
 Connector:  
 Verwendung für: / applicable for:  
 HOLDEN  
 ISUZU  
 TOYOTA



**8477**  
 Zündsystem / system  
 Denso  
 Polyester/Polyester  
 nicht entstört/not suppressed

Anschluß:  
 Connector:  
 Verwendung für: / applicable for:  
 BEDFORD  
 DAIHATSU  
 HOLDEN  
 SUZUKI  
 TOYOTA



**8479**  
 Zündsystem / system  
 Denso  
 Polypropylen/Polypropylen  
 nicht entstört/not suppressed

Anschluß:  
 Connector:  
 Verwendung für: / applicable for:  
 DAIHATSU  
 INNOCENTI



**8480**  
 Zündsystem / system  
 Denso  
 Polypropylen/Polypropylen  
 nicht entstört/not suppressed

Anschluß:  
 Connector:  
 Verwendung für: / applicable for:  
 DAIHATSU



**8482**  
 Zündsystem / system  
 Denso  
 Polypropylen/Polypropylen  
 nicht entstört/not suppressed

Anschluß:  
 Connector:  
 Verwendung für: / applicable for:  
 ISUZU  
 SUZUKI



M4 Anschluß  
 M4 connection



SAE Anschluß  
 SAE connection



Rastanschluß  
 Snap on connection



Buchsenanschluß  
 Bush connection



SAE Rillenanschluß  
 SAE-Groove connection



**8484**  
 Zündsystem / system  
 Denso  
 Polypropylen/Polypropylen  
 nicht entstört/not suppressed  
 Anschluß:  
 Connector:  
 Verwendung für: / applicable for:  
 MAZDA  
 TOYOTA



**8490**  
 Zündsystem / system  
 Denso  
 Polypropylen/Polypropylen  
 nicht entstört/not suppressed  
 Anschluß:  
 Connector:  
 Verwendung für: / applicable for:  
 DAIHATSU



**8485**  
 Zündsystem / system  
 Denso  
 Polypropylen/Polypropylen  
 nicht entstört/not suppressed  
 Anschluß:  
 Connector:  
 Verwendung für: / applicable for:  
 TOYOTA



**8491**  
 Zündsystem / system  
 Denso  
 Polypropylen/Polypropylen  
 nicht entstört/not suppressed  
 Anschluß:  
 Connector:  
 Verwendung für: / applicable for:  
 HOLDEN  
 SUZUKI



**8486**  
 Zündsystem / system  
 Denso  
 Polypropylen/Polypropylen  
 15000 Ohm entstört/suppressed  
 Anschluß:  
 Connector:  
 Verwendung für: / applicable for:  
 DAIHATSU  
 TOYOTA



**8492**  
 Zündsystem / system  
 Denso  
 Polypropylen/Polypropylen  
 nicht entstört/not suppressed  
 Anschluß:  
 Connector:  
 Verwendung für: / applicable for:  
 SUZUKI



**8487**  
 Zündsystem / system  
 Denso  
 Polypropylen/Polypropylen  
 nicht entstört/not suppressed  
 Anschluß:  
 Connector:  
 Verwendung für: / applicable for:  
 TOYOTA



**8493**  
 Zündsystem / system  
 Denso  
 Polypropylen/Polypropylen  
 nicht entstört/not suppressed  
 Anschluß:  
 Connector:  
 Verwendung für: / applicable for:  
 SUZUKI



**8488**  
 Zündsystem / system  
 Denso  
 Polypropylen/Polypropylen  
 nicht entstört/not suppressed  
 Anschluß:  
 Connector:  
 Verwendung für: / applicable for:  
 TOYOTA



**8494**  
 Zündsystem / system  
 Denso  
 Polypropylen/Polypropylen  
 nicht entstört/not suppressed  
 Anschluß:  
 Connector:  
 Verwendung für: / applicable for:  
 DAIHATSU



**8489**  
 Zündsystem / system  
 Denso  
 Polypropylen/Polypropylen  
 15000 Ohm entstört/suppressed  
 Anschluß:  
 Connector:  
 Verwendung für: / applicable for:  
 ISUZU  
 TOYOTA



**8496**  
 Zündsystem / system  
 Denso  
 Polypropylen/Polypropylen  
 nicht entstört/not suppressed  
 Anschluß:  
 Connector:  
 Verwendung für: / applicable for:  
 TOYOTA



M4 Anschluß  
 M4 connection



SAE Anschluß  
 SAE connection



Rastanschluß  
 Snap on connection



Buchsenanschluß  
 Bush connection



SAE Rillenanschluß  
 SAE-Groove connection



**8497**  
 Zündsystem / system  
**Denso**  
 Polypropylen/Polypropylen  
 nicht entzündet/not suppressed  
 Anschluß:  
 Connector:  
 Verwendung für: / applicable for:  
 SUBARU



**8506**  
 Zündsystem / system  
**Hitachi**  
 Polypropylen/Polypropylen  
 nicht entzündet/not suppressed  
 Anschluß:  
 Connector:  
 Verwendung für: / applicable for:  
 HONDA  
 NISSAN  
 SUBARU



**8499**  
 Zündsystem / system  
**Denso**  
 Polypropylen/Polypropylen  
 nicht entzündet/not suppressed  
 Anschluß:  
 Connector:  
 Verwendung für: / applicable for:  
 PEUGEOT  
 SUBARU



**8507**  
 Zündsystem / system  
**Hitachi**  
 Isolierstoff/Insulating material  
 nicht entzündet/not suppressed  
 Anschluß:  
 Connector:  
 Verwendung für: / applicable for:  
 HONDA  
 TRIUMPH



**8503**  
 Zündsystem / system  
**Hitachi**  
 Polypropylen/Polypropylen  
 nicht entzündet/not suppressed  
 Anschluß:  
 Connector:  
 Verwendung für: / applicable for:  
 HOLDEN  
 HONDA  
 ISUZU  
 NISSAN  
 SUBARU



**8508**  
 Zündsystem / system  
**Hitachi**  
 Polypropylen/Polypropylen  
 nicht entzündet/not suppressed  
 Anschluß:  
 Connector:  
 Verwendung für: / applicable for:  
 HONDA



**8504**  
 Zündsystem / system  
**Hitachi**  
 Isolierstoff/Insulating material  
 nicht entzündet/not suppressed  
 Anschluß:  
 Connector:  
 Verwendung für: / applicable for:  
 ISUZU  
 NISSAN



**8509**  
 Zündsystem / system  
**Hitachi**  
 Polypropylen/Polypropylen  
 nicht entzündet/not suppressed  
 Anschluß:  
 Connector:  
 Verwendung für: / applicable for:  
 HONDA  
 ROVER



**8505**  
 Zündsystem / system  
**Hitachi**  
 Polypropylen/Polypropylen  
 nicht entzündet/not suppressed  
 Anschluß:  
 Connector:  
 Verwendung für: / applicable for:  
 NISSAN



**8510**  
 Zündsystem / system  
**Hitachi**  
 Polypropylen/Polypropylen  
 nicht entzündet/not suppressed  
 Anschluß:  
 Connector:  
 Verwendung für: / applicable for:  
 HONDA



M4 Anschluß  
 M4 connection



SAE Anschluß  
 SAE connection



Rastanschluß  
 Snap on connection



Buchsenanschluß  
 Bush connection



SAE Rillenanschluß  
 SAE-Groove connection



**8513**  
 Zündsystem / system  
**Hitachi**  
 Polypropylen/Polypropylen  
 nicht entstört/not suppressed  
 Anschluß:  
 Connector:  
 Verwendung für: / applicable for:  
 HOLDEN  
 NISSAN  
 SUBARU



**8523**  
 Zündsystem / system  
**Hitachi**  
 Polypropylen/Polypropylen  
 nicht entstört/not suppressed  
 Anschluß:  
 Connector:  
 Verwendung für: / applicable for:  
 NISSAN



**8516**  
 Zündsystem / system  
**Hitachi**  
 Polypropylen/Polypropylen  
 nicht entstört/not suppressed  
 Anschluß:  
 Connector:  
 Verwendung für: / applicable for:  
 MAZDA



**8524**  
 Zündsystem / system  
**Hitachi**  
 Polypropylen/Polypropylen  
 nicht entstört/not suppressed  
 Anschluß:  
 Connector:  
 Verwendung für: / applicable for:  
 NISSAN



**8517**  
 Zündsystem / system  
**Hitachi**  
 Polyester/Polyester  
 nicht entstört/not suppressed  
 Anschluß:  
 Connector:  
 Verwendung für: / applicable for:  
 NISSAN



**8527**  
 Zündsystem / system  
**Hitachi**  
**Mitsubishi**  
 Isolierstoff/Insulating material  
 nicht entstört/not suppressed  
 Anschluß:  
 Connector:  
 Verwendung für: / applicable for:  
 HONDA  
 NISSAN



**8518**  
 Zündsystem / system  
**Hitachi**  
 Polypropylen/Polypropylen  
 nicht entstört/not suppressed  
 Anschluß:  
 Connector:  
 Verwendung für: / applicable for:  
 HONDA



**8528**  
 Zündsystem / system  
**Mitsubishi**  
 Polyester/Polyester  
 nicht entstört/not suppressed  
 Anschluß:  
 Connector:  
 Verwendung für: / applicable for:  
 HYUNDAI  
 MAZDA  
 MITSUBISHI  
 NISSAN



**8519**  
 Zündsystem / system  
**Hitachi**  
 Polypropylen/Polypropylen  
 nicht entstört/not suppressed  
 Anschluß:  
 Connector:  
 Verwendung für: / applicable for:  
 HONDA



**8529**  
 Zündsystem / system  
**Mitsubishi**  
 Polypropylen/Polypropylen  
 nicht entstört/not suppressed  
 Anschluß:  
 Connector:  
 Verwendung für: / applicable for:  
 MAZDA  
 MITSUBISHI  
 NISSAN



**8522**  
 Zündsystem / system  
**Hitachi**  
 Polypropylen/Polypropylen  
 nicht entstört/not suppressed  
 Anschluß:  
 Connector:  
 Verwendung für: / applicable for:  
 SUBARU



M4 Anschluß  
 M4 connection



SAE Anschluß  
 SAE connection



Rastanschluß  
 Snap on connection



Buchsenanschluß  
 Bush connection



SAE Rillenanschluß  
 SAE-Groove connection



**8530**  
Zündsystem / system  
Mitsubishi  
Polyester/Polyester  
nicht entstört/not suppressed

Anschluß:  
Connector:  
Verwendung für: / applicable for:  
FORD  
HYUNDAI  
MAZDA  
MITSUBISHI  
NISSAN



**8536**  
Zündsystem / system  
Mitsubishi  
Polypropylen/Polypropylen  
nicht entstört/not suppressed

Anschluß:  
Connector:  
Verwendung für: / applicable for:  
FORD  
HYUNDAI  
KIA  
MAZDA



**8532**  
Zündsystem / system  
Mitsubishi  
Polypropylen/Polypropylen  
nicht entstört/not suppressed

Anschluß:  
Connector:  
Verwendung für: / applicable for:  
MAZDA



**8538**  
Zündsystem / system  
Mitsubishi  
Polypropylen/Polypropylen  
nicht entstört/not suppressed

Anschluß:  
Connector:  
Verwendung für: / applicable for:  
MAZDA



**8533**  
Zündsystem / system  
Mitsubishi  
Polypropylen/Polypropylen  
nicht entstört/not suppressed

Anschluß:  
Connector:  
Verwendung für: / applicable for:  
MAZDA



**8540**  
Zündsystem / system  
Mitsubishi  
Polypropylen/Polypropylen  
nicht entstört/not suppressed

Anschluß:  
Connector:  
Verwendung für: / applicable for:  
MAZDA



**8534**  
Zündsystem / system  
Mitsubishi  
Polypropylen/Polypropylen  
nicht entstört/not suppressed

Anschluß:  
Connector:  
Verwendung für: / applicable for:  
NISSAN



**8542**  
Zündsystem / system  
Mitsubishi  
Polypropylen/Polypropylen  
nicht entstört/not suppressed

Anschluß:  
Connector:  
Verwendung für: / applicable for:  
HOLDEN  
MAZDA  
SUZUKI



**8535**  
Zündsystem / system  
Mitsubishi  
Polypropylen/Polypropylen  
nicht entstört/not suppressed

Anschluß:  
Connector:  
Verwendung für: / applicable for:  
HOLDEN  
MAZDA



**8543**  
Zündsystem / system  
Mitsubishi  
Polypropylen/Polypropylen  
nicht entstört/not suppressed

Anschluß:  
Connector:  
Verwendung für: / applicable for:  
NISSAN



M4 Anschluß  
M4 connection



SAE Anschluß  
SAE connection



Rastanschluß  
Snap on connection



Buchsenanschluß  
Bush connection



SAE Rillenanschluß  
SAE-Groove connection



**8544**  
 Zündsystem / system  
 Mitsubishi  
 Polypropylen/Polypropylen  
 nicht entzündet/not suppressed  
 Anschluß:  
 Connector:  
 Verwendung für: / applicable for:  
 MAZDA



**8545**  
 Zündsystem / system  
 Mitsubishi  
 Polypropylen/Polypropylen  
 nicht entzündet/not suppressed  
 Anschluß:  
 Connector:  
 Verwendung für: / applicable for:  
 CHRYSLER  
 MITSUBISHI



**8546**  
 Zündsystem / system  
 Mitsubishi  
 Polypropylen/Polypropylen  
 nicht entzündet/not suppressed  
 Anschluß:  
 Connector:  
 Verwendung für: / applicable for:  
 NISSAN



**8547**  
 Zündsystem / system  
 Mitsubishi  
 Polypropylen/Polypropylen  
 nicht entzündet/not suppressed  
 Anschluß:  
 Connector:  
 Verwendung für: / applicable for:  
 MITSUBISHI



**8549**  
 Zündsystem / system  
 Mitsubishi  
 Polypropylen/Polypropylen  
 nicht entzündet/not suppressed  
 Anschluß:  
 Connector:  
 Verwendung für: / applicable for:  
 MITSUBISHI



**8588**  
 Zündsystem / system  
 Lucas  
 Ford  
 Isolierstoff/Insulating material  
 nicht entzündet/not suppressed  
 Anschluß:  
 Connector:  
 Verwendung für: / applicable for:  
 FORD



**8592**  
 Zündsystem / system  
 Lucas  
 Ford  
 Isolierstoff/Insulating material  
 nicht entzündet/not suppressed  
 Anschluß:  
 Connector:  
 Verwendung für: / applicable for:  
 AUSTIN  
 AUSTIN MORRIS  
 HILLMANN  
 INNOCENTI  
 LAND ROVER  
 LOTUS  
 MG  
 MORRIS  
 RENAULT  
 ROVER  
 TRIUMPH  
 WOLSELEY



**8594**  
 Zündsystem / system  
 Lucas  
 Ford  
 Polyester/Polyester  
 nicht entzündet/not suppressed  
 Anschluß:  
 Connector:  
 Verwendung für: / applicable for:  
 FORD



**8595**  
 Zündsystem / system  
 Lucas  
 Ford  
 Polyester/Polyester  
 nicht entzündet/not suppressed  
 Anschluß:  
 Connector:  
 Verwendung für: / applicable for:  
 FORD



**8597**  
 Zündsystem / system  
 Lucas  
 Ford  
 Polypropylen/Polypropylen  
 nicht entzündet/not suppressed  
 Anschluß:  
 Connector:  
 Verwendung für: / applicable for:  
 FORD



**8599**  
 Zündsystem / system  
 Ford  
 Polyester/Polyester  
 nicht entzündet/not suppressed  
 Anschluß:  
 Connector:  
 Verwendung für: / applicable for:  
 FORD



M4 Anschluß  
 M4 connection



SAE Anschluß  
 SAE connection



Rastanschluß  
 Snap on connection



Buchsenanschluß  
 Bush connection



SAE Rillenanschluß  
 SAE-Groove connection



**8617**  
 Zündsystem / system  
 Femsä  
 Marelli  
 Isolierstoff/Insulating material  
 nicht entstört/not suppressed  
 Anschluß:  
 Connector:  
 Verwendung für: / applicable for:  
 ALFA ROMEO



**8622**  
 Zündsystem / system  
 Femsä  
 Marelli  
 Isolierstoff/Insulating material  
 nicht entstört/not suppressed  
 Anschluß:  
 Connector:  
 Verwendung für: / applicable for:  
 RENAULT



**8635**  
 Zündsystem / system  
 SEV-Marchal  
 Isolierstoff/Insulating material  
 nicht entstört/not suppressed  
 Anschluß:  
 Connector:  
 Verwendung für: / applicable for:  
 RENAULT



**8637**  
 Zündsystem / system  
 SEV-Marchal  
 Isolierstoff/Insulating material  
 nicht entstört/not suppressed  
 Anschluß:  
 Connector:  
 Verwendung für: / applicable for:  
 RENAULT



**8640**  
 Zündsystem / system  
 SEV-Marchal  
 Isolierstoff/Insulating material  
 nicht entstört/not suppressed  
 Anschluß:  
 Connector:  
 Verwendung für: / applicable for:  
 CITROEN



**8642**  
 Zündsystem / system  
 SEV-Marchal  
 Isolierstoff/Insulating material  
 nicht entstört/not suppressed  
 Anschluß:  
 Connector:  
 Verwendung für: / applicable for:  
 TALBOT



**8643**  
 Zündsystem / system  
 SEV-Marchal  
 Isolierstoff/Insulating material  
 nicht entstört/not suppressed  
 Anschluß:  
 Connector:  
 Verwendung für: / applicable for:  
 PEUGEOT  
 RENAULT



**8644**  
 Zündsystem / system  
 SEV-Marchal  
 Isolierstoff/Insulating material  
 nicht entstört/not suppressed  
 Anschluß:  
 Connector:  
 Verwendung für: / applicable for:  
 RENAULT



**8685**  
 Zündsystem / system  
 Paris-Rhone  
 Polyester/Polyester  
 nicht entstört/not suppressed  
 Anschluß:  
 Connector:  
 Verwendung für: / applicable for:  
 FIAT  
 LANCIA  
 RENAULT  
 TALBOT



**8687**  
 Zündsystem / system  
 Paris-Rhone  
 Isolierstoff/Insulating material  
 nicht entstört/not suppressed  
 Anschluß:  
 Connector:  
 Verwendung für: / applicable for:  
 PEUGEOT  
 RENAULT  
 VW



**8688**  
 Zündsystem / system  
 Paris-Rhone  
 Polyester/Polyester  
 nicht entstört/not suppressed  
 Anschluß:  
 Connector:  
 Verwendung für: / applicable for:  
 CITROEN



M4 Anschluß  
 M4 connection



SAE Anschluß  
 SAE connection



Rastanschluß  
 Snap on connection



Buchsenanschluß  
 Bush connection



SAE Rillenanschluß  
 SAE-Groove connection



**8701**  
 Zündsystem / system  
**Chrysler**  
 PBT/PBT  
 nicht entstört/not suppressed  
 Anschluß:  
 Connector:  
 Verwendung für: / applicable for:  
 TALBOT



**8726**  
 Zündsystem / system  
**Mitsubishi**  
 Polypropylen/Polypropylen  
 nicht entstört/not suppressed  
 Anschluß:  
 Connector:  
 Verwendung für: / applicable for:  
 MITSUBISHI



**8702**  
 Zündsystem / system  
**Chrysler**  
 PBT/PBT  
 nicht entstört/not suppressed  
 Anschluß:  
 Connector:  
 Verwendung für: / applicable for:  
 VOLVO



**8727**  
 Zündsystem / system  
**Mitsubishi**  
 Polypropylen/Polypropylen  
 nicht entstört/not suppressed  
 Anschluß:  
 Connector:  
 Verwendung für: / applicable for:  
 MITSUBISHI



**8720**  
 Zündsystem / system  
**Mitsubishi**  
 Polypropylen/Polypropylen  
 5000 Ohm entstört/suppressed  
 Anschluß:  
 Connector:  
 Verwendung für: / applicable for:  
 MAZDA



**8728**  
 Zündsystem / system  
**Mitsubishi**  
 Polypropylen/Polypropylen  
 Anschluß:  
 Connector:  
 Verwendung für: / applicable for:  
 MITSUBISHI



**8721**  
 Zündsystem / system  
**Mitsubishi**  
 Polypropylen/Polypropylen  
 5000 Ohm entstört/suppressed  
 Anschluß:  
 Connector:  
 Verwendung für: / applicable for:  
 MAZDA



**8729**  
 Zündsystem / system  
**Mitsubishi**  
 Polypropylen/Polypropylen  
 Anschluß:  
 Connector:  
 Verwendung für: / applicable for:  
 MITSUBISHI



**8722**  
 Zündsystem / system  
**Mitsubishi**  
 Polypropylen/Polypropylen  
 5000 Ohm entstört/suppressed  
 Anschluß:  
 Connector:  
 Verwendung für: / applicable for:  
 MAZDA



**8730**  
 Zündsystem / system  
**Mitsubishi**  
 Polypropylen/Polypropylen  
 Anschluß:  
 Connector:  
 Verwendung für: / applicable for:  
 MITSUBISHI



**8723**  
 Zündsystem / system  
**Hitachi**  
 Polypropylen/Polypropylen  
 nicht entstört/not suppressed  
 Anschluß:  
 Connector:  
 Verwendung für: / applicable for:  
 MAZDA



**8750**  
 Zündsystem / system  
**Denso**  
 Polypropylen/Polypropylen  
 nicht entstört/not suppressed  
 Anschluß:  
 Connector:  
 Verwendung für: / applicable for:  
 TOYOTA



M4 Anschluß  
 M4 connection



SAE Anschluß  
 SAE connection



Rastanschluß  
 Snap on connection



Buchsenanschluß  
 Bush connection



SAE Rillenanschluß  
 SAE-Groove connection





**8751**  
 Zündsystem / system  
**Denso**  
 Polypropylen/Polypropylen  
 nicht entzündet/not suppressed  
 Anschluß:  
 Connector:  
 Verwendung für: / applicable for:  
 TOYOTA



**8759**  
 Zündsystem / system  
**Denso**  
 Polypropylen/Polypropylen  
 Anschluß:  
 Connector:  
 Verwendung für: / applicable for:  
 DAIHATSU



**8752**  
 Zündsystem / system  
**Denso**  
 Polypropylen/Polypropylen  
 nicht entzündet/not suppressed  
 Anschluß:  
 Connector:  
 Verwendung für: / applicable for:  
 TOYOTA



**8787**  
 Zündsystem / system  
**Lucas**  
 Polypropylen/Polypropylen  
 nicht entzündet/not suppressed  
 Anschluß:  
 Connector:  
 Verwendung für: / applicable for:  
 NISSAN



**8754**  
 Zündsystem / system  
**Denso**  
 Polypropylen/Polypropylen  
 15000 Ohm entzündet/suppressed  
 Anschluß:  
 Connector:  
 Verwendung für: / applicable for:  
 TOYOTA



**8788**  
 Zündsystem / system  
**Hitachi**  
 Polypropylen/Polypropylen  
 nicht entzündet/not suppressed  
 Anschluß:  
 Connector:  
 Verwendung für: / applicable for:  
 NISSAN



**8755**  
 Zündsystem / system  
**Denso**  
 Polypropylen/Polypropylen  
 15000 Ohm entzündet/suppressed  
 Anschluß:  
 Connector:  
 Verwendung für: / applicable for:  
 TOYOTA



**8789**  
 Zündsystem / system  
**Hitachi**  
 Polypropylen/Polypropylen  
 nicht entzündet/not suppressed  
 Anschluß:  
 Connector:  
 Verwendung für: / applicable for:  
 NISSAN



**8756**  
 Zündsystem / system  
**Denso**  
 Polypropylen/Polypropylen  
 nicht entzündet/not suppressed  
 Anschluß:  
 Connector:  
 Verwendung für: / applicable for:  
 TOYOTA



**8790**  
 Zündsystem / system  
**Hitachi**  
 Polypropylen/Polypropylen  
 nicht entzündet/not suppressed  
 Anschluß:  
 Connector:  
 Verwendung für: / applicable for:  
 NISSAN



**8758**  
 Zündsystem / system  
**Denso**  
 Polypropylen/Polypropylen  
 nicht entzündet/not suppressed  
 Anschluß:  
 Connector:  
 Verwendung für: / applicable for:  
 SUZUKI



**8791**  
 Zündsystem / system  
**Mitsubishi**  
 Polypropylen/Polypropylen  
 nicht entzündet/not suppressed  
 Anschluß:  
 Connector:  
 Verwendung für: / applicable for:  
 NISSAN



M4 Anschluß  
 M4 connection



SAE Anschluß  
 SAE connection



Rastanschluß  
 Snap on connection



Buchsenanschluß  
 Bush connection



SAE Rillenanschluß  
 SAE-Groove connection



**8793**  
 Zündsystem / system  
**Mitsubishi**  
 Polypropylen/Polypropylen  
 nicht entstört/not suppressed  
 Anschluß:  
 Connector:  
 Verwendung für: / applicable for:  
 NISSAN



**8794**  
 Zündsystem / system  
**Lucas**  
 Polypropylen/Polypropylen  
 Anschluß:  
 Connector:  
 Verwendung für: / applicable for:  
 NISSAN



**8834**  
 Zündsystem / system  
**Russia**  
 Isolierstoff/Insulating material  
 nicht entstört/not suppressed  
 Anschluß:  
 Connector:  
 Verwendung für: / applicable for:  
 LADA  
 LADA (Shiguli)



**8835**  
 Zündsystem / system  
**Marelli**  
 Polyester/Polyester  
 nicht entstört/not suppressed  
 Anschluß:  
 Connector:  
 Verwendung für: / applicable for:  
 FIAT  
 LANCIA



**8836**  
 Zündsystem / system  
**Marelli**  
 Polyester/Polyester  
 nicht entstört/not suppressed  
 Anschluß:  
 Connector:  
 Verwendung für: / applicable for:  
 FIAT  
 LANCIA



M4 Anschluß  
 M4 connection



SAE Anschluß  
 SAE connection



Rastanschluß  
 Snap on connection



Buchsenanschluß  
 Bush connection



SAE Rillenanschluß  
 SAE-Groove connection

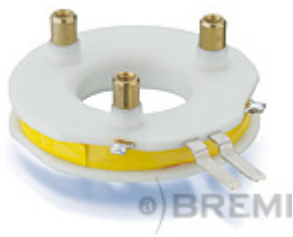

**16500**  
Zündsystem / system  
Bosch



**16503**  
Zündsystem / system  
Bosch



**16505**  
Zündsystem / system  
Bosch



**16509**  
Zündsystem / system  
Bosch



**16510**  
Zündsystem / system  
Bosch



**16511**  
Zündsystem / system  
Bosch



**16512**  
Zündsystem / system  
Bosch



**16513**  
Zündsystem / system  
Bosch



**16514**  
Zündsystem / system  
Bosch



**16515**  
Zündsystem / system  
Bosch



**16516**  
Zündsystem / system  
Bosch



**16517**  
Zündsystem / system  
Bosch





**16518**  
Zündsystem / system  
Bosch



**16519**  
Zündsystem / system  
Bosch

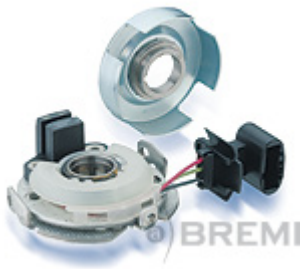

**16520**  
Zündsystem / system  
Bosch



**16521**  
Zündsystem / system  
Bosch



**16522**  
Zündsystem / system  
Bosch



**16523**  
Zündsystem / system  
Bosch



**16524**  
Zündsystem / system  
Bosch



**16525**  
Zündsystem / system  
Bosch



**16526**  
Zündsystem / system  
Bosch



**16527**  
Zündsystem / system  
Bosch

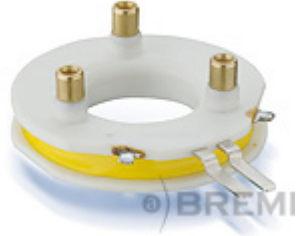

**16528**  
Zündsystem / system  
Bosch

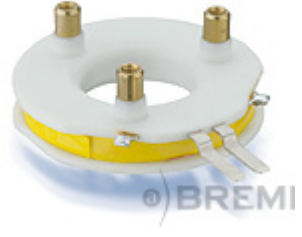

**16529**  
Zündsystem / system  
Bosch



**16600**  
Zündsystem / system  
Ducellier

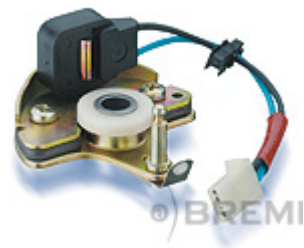

**16700**  
Zündsystem / system  
Marelli



**16601**  
Zündsystem / system  
Ducellier



**16701**  
Zündsystem / system  
Marelli



**16602**  
Zündsystem / system  
Ducellier



**16702**  
Zündsystem / system  
Marelli



**16603**  
Zündsystem / system  
Ducellier



**16604**  
Zündsystem / system  
Ducellier



**16605**  
Zündsystem / system  
Ducellier

**14001**  
Zündsystem / system  
Bosch



**14002**  
Zündsystem / system  
Bosch



**14003**  
Zündsystem / system  
Bosch



**14004**  
Zündsystem / system  
Bosch



**14005**  
Zündsystem / system  
Bosch



**14006**  
Zündsystem / system  
Bosch



**14007**  
Zündsystem / system  
Bosch



**14008**  
Zündsystem / system  
Bosch



**14009**  
Zündsystem / system  
Bosch



**14010**  
Zündsystem / system  
Bosch

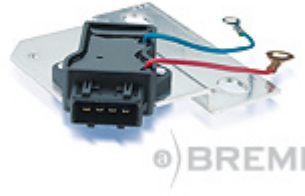

**14011**  
Zündsystem / system  
Bosch



**14012**  
Zündsystem / system  
Bosch



**14014**  
Zündsystem / system  
Bosch



**14015**  
Zündsystem / system  
Bosch



**14016**  
Zündsystem / system  
Bosch

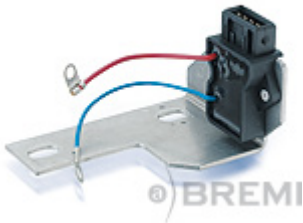

**14017**  
Zündsystem / system  
Bosch

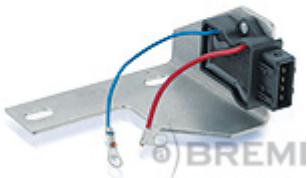

**14018**  
Zündsystem / system  
Bosch



**14019**  
Zündsystem / system  
Bosch



**14021**  
Zündsystem / system  
Bosch

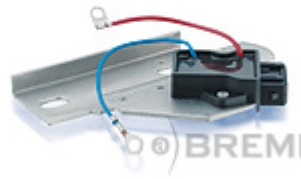

**14022**  
Zündsystem / system  
Bosch



**14050**  
Zündsystem / system  
Bosch



**14051**  
Zündsystem / system



**14052**  
Zündsystem / system  
Bosch



**14053**  
Zündsystem / system  
Bosch



**14054**  
Zündsystem / system



BREMI

**14100**  
Zündsystem / system  
Delco-Remy



BREMI

**14101**  
Zündsystem / system  
Delco-Remy



BREMI

**14102**  
Zündsystem / system  
Delco-Remy

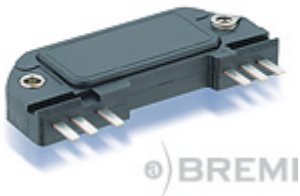

BREMI

**14103**  
Zündsystem / system  
Delco-Remy



BREMI

**14104**  
Zündsystem / system  
Delco-Remy



BREMI

**14150**  
Zündsystem / system  
Lucas

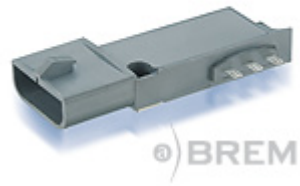

BREMI

**14151**  
Zündsystem / system  
Lucas



BREMI

**14152**  
Zündsystem / system  
Lucas



BREMI

**14153**  
Zündsystem / system  
Lucas



BREMI

**14154**  
Zündsystem / system  
Lucas



BREMI

**14155**  
Zündsystem / system  
Lucas



BREMI



**14156**  
Zündsystem / system  
Lucas



**14300**  
Zündsystem / system  
Marelli



**14200**  
Zündsystem / system  
Hitachi



**14301**  
Zündsystem / system  
Marelli



**14201**  
Zündsystem / system  
Hitachi



**14350**  
Zündsystem / system  
Mitsubishi

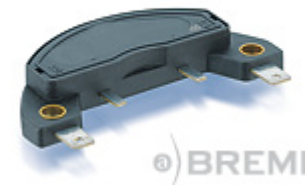

**14202**  
Zündsystem / system  
Hitachi



**14352**  
Zündsystem / system  
Mitsubishi



**14203**  
Zündsystem / system  
Hitachi



**14353**  
Zündsystem / system  
Mitsubishi



**14250**  
Zündsystem / system  
Lucas  
Marelli



**14355**  
Zündsystem / system  
Mitsubishi



**14400**  
Zündsystem / system  
Valeo



**14450**  
Zündsystem / system  
Valeo



**14500**  
Zündsystem / system  
Denso  
Hitachi

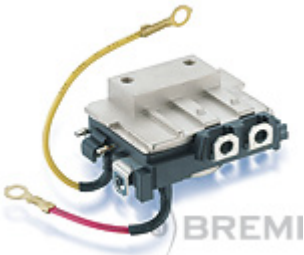

**14501**  
Zündsystem / system  
Valeo

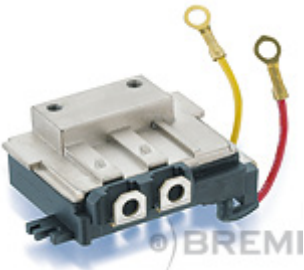

**14502**  
Zündsystem / system  
Valeo

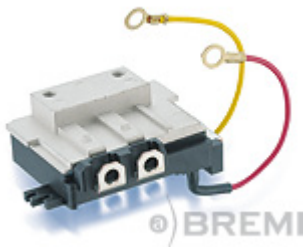

**14600**  
Zündsystem / system  
Ducellier  
Ohne Zündspule, mit Klemmkontakten für Zündspulenanschluß  
Without ignition coil, with clamp connection for ignition coil connector



**14601**  
Zündsystem / system  
Ducellier  
Ohne Zündspule, mit Schraubverbindung für Zündspulenanschluß  
Without ignition coil, with screw connection for ignition coil connector



**14650**  
Zündsystem / system  
Bosch



**14700**  
Zündsystem / system  
Ducellier  
Ohne Zündspule, mit Klemmkontakten für Zündspulenanschluß  
Without ignition coil, with clamp connection for ignition coil connector



**14750**  
Zündsystem / system  
Mitsubishi



**14800**  
Zündsystem / system  
Hitachi





**11700**  
12 Volt  
Verwendung für: / applicable for:  
SEAT

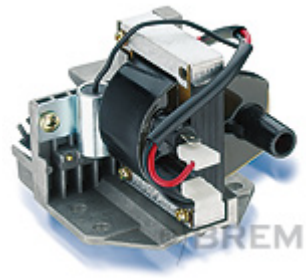

**11710**  
12 Volt  
Verwendung für: / applicable for:  
LANCIA



**11701**  
12 Volt  
Verwendung für: / applicable for:  
FIAT  
LANCIA



**11713**  
12 Volt  
Verwendung für: / applicable for:  
VOLVO



**11703**  
12 Volt  
Verwendung für: / applicable for:  
AUDI



**11714**  
12 Volt  
Verwendung für: / applicable for:  
PEUGEOT  
RENAULT



**11705**  
12 Volt  
Verwendung für: / applicable for:  
ALFA ROMEO



**11715**  
12 Volt  
Verwendung für: / applicable for:  
OPEL



**11706**  
12 Volt  
Verwendung für: / applicable for:  
ALFA ROMEO



**11716**  
12 Volt  
Verwendung für: / applicable for:  
OPEL



**11709**  
12 Volt  
Verwendung für: / applicable for:  
AUDI



**11717**  
12 Volt  
Verwendung für: / applicable for:  
OPEL





**11718**  
12 Volt

Verwendung für: / applicable for:  
OPEL

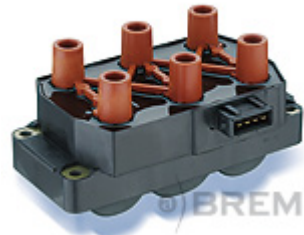

**11727**  
12 Volt

Verwendung für: / applicable for:  
ALFA ROMEO  
FIAT  
LANCIA



**11719**  
12 Volt

Verwendung für: / applicable for:  
RENAULT



**11730**  
12 Volt

Verwendung für: / applicable for:  
FORD



**11720**  
12 Volt

Verwendung für: / applicable for:  
DACIA  
NISSAN  
RENAULT



**11731**  
12 Volt

Verwendung für: / applicable for:  
AUDI  
SEAT  
SKODA  
SVW  
VW  
VW CHINA



**11722**  
12 Volt

Verwendung für: / applicable for:  
RENAULT



**11732**  
12 Volt

Verwendung für: / applicable for:  
BMW



**11723**  
12 Volt

Verwendung für: / applicable for:  
RENAULT



**11800**

Hochleistungs-Zündspule für kontaktgesteuerte Zündanlagen ohne Vorwiderstand  
High performance ignition coil for conventional (contact points) ignition systems without series resistor

6 Volt



**11726**  
12 Volt

Verwendung für: / applicable for:  
HONDA

Verwendung für: / applicable for:  
BORGWARD  
OPEL  
PORSCHE  
RENAULT

**11801**

Hochleistungs-Zündspule für kontaktgesteuerte Zündanlagen ohne Vorwiderstand  
High performance ignition coil for conventional (contact points) ignition systems without series resistor

12 Volt

Verwendung für: / applicable for:

ALFA ROMEO  
AUDI  
AUSTIN  
AUSTIN HEALEY  
AUTOBIANCHI  
BEDFORD  
BMW  
CITROEN  
DACIA  
DAF  
FIAT  
FORD  
GAZ  
HILLMANN  
INNOCENTI  
ISUZU  
LADA  
LADA (Shiguli)  
LANCIA  
MERCEDES-BENZ  
MITSUBISHI  
MORGAN  
MORRIS  
NISSAN  
NSU  
OPEL  
PEUGEOT  
PININFARINA  
PORSCHE  
RENAULT  
SAAB  
SEAT  
SKOD

**11802**

Orange Resistor- Hochleistungs-Zündspule. Kaltstartsicher mit Startanhebung für kontaktgesteuerte Zündanlagen mit eingebautem 1,8 Ohm Vorwiderstand  
High performance ignition coil (orange) for conventional (contact points) ignition systems, safety cold start with start release for ignitions with 1.8 Ohm series resistor

12 Volt

Verwendung für: / applicable for:

ALFA ROMEO  
AUSTIN  
CITROEN  
DAIHATSU  
ISUZU  
LAND ROVER  
MERCEDES-BENZ  
MG  
NISSAN  
SKODA  
SUZUKI  
TOYOTA  
TRIUMPH  
VAUXHALL

**11803**

Wie Typ 11802, jedoch mit beige-packtem 1,8 Ohm Vorwiderstand zur Nachrüstung  
Like type 11802, but including 1.8 Ohm series resistor for supplementary assembly

12 Volt

Verwendung für: / applicable for:

CITROEN  
FIAT  
HONDA  
HYUNDAI  
MITSUBISHI  
NISSAN  
PEUGEOT  
RENAULT  
SUBARU  
SUZUKI  
TOYOTA

**11805**

12 Volt

Verwendung für: / applicable for:

MERCEDES-BENZ  
PORSCHE  
RENAULT

**11806**

12 Volt

Verwendung für: / applicable for:

AUDI  
VW

**11810**

12 Volt

Verwendung für: / applicable for:

FORD  
MAZDA

**11812**

12 Volt

Verwendung für: / applicable for:

FORD  
OPEL



**11814**  
12 Volt

Verwendung für: / applicable for:  
MERCEDES-BENZ  
MORGAN  
SAAB



**11816**  
12 Volt

Verwendung für: / applicable for:  
ALFA ROMEO  
BMW  
PORSCHE



**11819**  
12 Volt

Verwendung für: / applicable for:  
BMW



**11820**  
12 Volt

Verwendung für: / applicable for:  
BMW  
MITSUBISHI  
TOYOTA



**11821**

Für kontaktgesteuerte Fahrzeuge mit 4- und 6- Zylindern. Zündspule arbeitet mit 1,8 Ohm Vorwiderstand als Festwiderstand oder Widerstandskabel  
For vehicles with 4- and 6- cylinders and conventional (contact points) ignition systems. Ignition coil operates with 1.8 Ohm fixed series resistor or resistance lead

12 Volt

Verwendung für: / applicable for:  
ALFA ROMEO  
AUDI  
AUSTIN  
BMW  
CITROEN  
FIAT  
LADA  
LADA (Shiguli)  
LANCIA  
MITSUBISHI  
NISSAN  
PEUGEOT  
PININFARINA  
PORSCHE  
SAAB  
VAUXHALL  
VOLVO  
VW



**11822**  
12 Volt

Verwendung für: / applicable for:  
AUDI  
SEAT  
VW  
WARTBURG



**11824**  
12 Volt

Verwendung für: / applicable for:  
AUDI



**11825**  
12 Volt

Verwendung für: / applicable for:  
VOLVO



**11855T**

12 Volt

Verwendung für: / applicable for:  
BMW



**11864T**

Zündkerzensteckerlänge 122mm  
Length of spark plug terminal  
122mm

12 Volt

Verwendung für: / applicable for:  
BMW



**11856T**

Zündkerzensteckerlänge 118mm  
Length of spark plug terminal  
118mm

12 Volt

Verwendung für: / applicable for:  
BMW



**11866T**

12 Volt

Verwendung für: / applicable for:  
AUDI  
SKODA  
VW



**11857T**

Zündkerzensteckerlänge 122mm  
Length of spark plug terminal  
122mm

12 Volt

Verwendung für: / applicable for:  
BMW



**11869**

Zündkerzensteckerlänge 110mm  
Length of spark plug terminal  
110mm

12 Volt

Verwendung für: / applicable for:  
AUDI  
SEAT  
SKODA  
VW



**11859T**

12 Volt

Verwendung für: / applicable for:  
BMW  
ROLLS-ROYCE  
ROVER



**11871**

Zündkerzensteckerlänge 132mm  
Length of spark plug terminal  
132mm

12 Volt

Verwendung für: / applicable for:  
AUDI



**11860T**

Zündkerzensteckerlänge 118mm  
Length of spark plug terminal  
118mm

12 Volt

Verwendung für: / applicable for:  
ALPINA  
BMW  
LAND ROVER



**11873**

12 Volt

Verwendung für: / applicable for:  
CHRYSLER  
MERCEDES-BENZ  
MERCEDES-BENZ (FJDA)



**11863T**

Zündkerzensteckerlänge 151mm  
Length of spark plug terminal  
151mm

12 Volt

Verwendung für: / applicable for:  
BMW



**11875**

12 Volt

Verwendung für: / applicable for:  
FORD  
MAZDA



**11876**  
12 Volt  
Verwendung für: / applicable for:  
CHEVROLET  
HOLDEN  
OPEL  
VAUXHALL



**11877**  
12 Volt  
Verwendung für: / applicable for:  
ALPINE  
RENAULT  
VOLVO



**11878**  
12 Volt  
Verwendung für: / applicable for:  
CITROEN  
PEUGEOT



**11879**  
12 Volt  
Verwendung für: / applicable for:  
CITROEN  
PEUGEOT



**11880**  
12 Volt  
Verwendung für: / applicable for:  
CITROEN  
PEUGEOT



**11881**  
12 Volt  
Verwendung für: / applicable for:  
CITROEN  
PEUGEOT  
ROVER



**11882**  
12 Volt  
Verwendung für: / applicable for:  
CITROEN  
FIAT  
LANCIA  
PEUGEOT



**11883**  
12 Volt  
Verwendung für: / applicable for:  
ALFA ROMEO  
CITROEN  
FERRARI  
FIAT  
KIA  
LANCIA  
LAND ROVER  
PEUGEOT  
PROTON  
VW



**11884**  
12 Volt  
Verwendung für: / applicable for:  
CITROEN  
PEUGEOT



**11885**  
12 Volt  
Verwendung für: / applicable for:  
MAZDA



**11886**  
12 Volt  
Verwendung für: / applicable for:  
HONDA  
ROVER



**11887**  
12 Volt  
Verwendung für: / applicable for:  
HYUNDAI  
MITSUBISHI





**11888**  
12 Volt

Verwendung für: / applicable for:  
FORD  
INFINITI  
NISSAN



**11889**  
12 Volt

Verwendung für: / applicable for:  
MAZDA  
NISSAN



**11890**  
12 Volt

Verwendung für: / applicable for:  
MITSUBISHI



**11892**  
12 Volt

Verwendung für: / applicable for:  
AUDI  
PEUGEOT  
SEAT  
VW



**11893**  
12 Volt

Verwendung für: / applicable for:  
AUDI  
SEAT  
SKODA  
VW



**11894T**  
12 Volt

Verwendung für: / applicable for:  
ROVER



**11895**  
12 Volt

Verwendung für: / applicable for:  
OPEL  
VAUXHALL

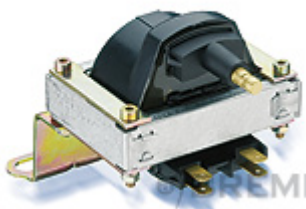

**11896**  
12 Volt

Verwendung für: / applicable for:  
OPEL  
VAUXHALL



**11897**  
12 Volt

Verwendung für: / applicable for:  
AUTOBIANCHI  
FIAT  
LANCIA



**11898**  
12 Volt

Verwendung für: / applicable for:  
FIAT  
LANCIA



**11899**  
12 Volt

Verwendung für: / applicable for:  
ALFA ROMEO  
FIAT  
LANCIA



**11900**  
12 Volt

Verwendung für: / applicable for:  
FIAT  
LANCIA



**11906**  
12 Volt  
Verwendung für: / applicable for:  
VW



**11913**  
12 Volt  
Verwendung für: / applicable for:  
FORD  
HONDA



**11907**  
12 Volt  
Verwendung für: / applicable for:  
MAZDA



**11914**  
12 Volt  
Verwendung für: / applicable for:  
SUZUKI



**11908**  
12 Volt  
Verwendung für: / applicable for:  
CITROEN  
FIAT  
PEUGEOT



**11915**  
12 Volt  
Verwendung für: / applicable for:  
HONDA  
ROVER



**11910**  
12 Volt  
Verwendung für: / applicable for:  
HOLDEN  
OPEL  
VAUXHALL



**11916**  
12 Volt  
Verwendung für: / applicable for:  
RENAULT



**11911**  
12 Volt  
Verwendung für: / applicable for:  
OPEL  
SAAB  
VAUXHALL



**11917**  
12 Volt  
Verwendung für: / applicable for:  
RENAULT



**11912**  
12 Volt  
Verwendung für: / applicable for:  
OPEL  
VAUXHALL



**11921**  
12 Volt  
Verwendung für: / applicable for:  
DAIHATSU



**11922**  
12 Volt  
Verwendung für: / applicable for:  
CHEVROLET  
HOLDEN  
OPEL  
VAUXHALL

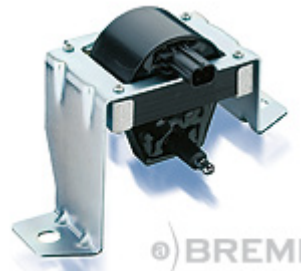

**11935**  
12 Volt  
Verwendung für: / applicable for:  
LAND ROVER  
ROVER



**11925**  
12 Volt  
Verwendung für: / applicable for:  
DAIHATSU



**11937**  
12 Volt  
Verwendung für: / applicable for:  
FORD



**11927**  
12 Volt  
Verwendung für: / applicable for:  
KIA



**11938**  
Zündmodul an Zündspule gesteckt  
12 Volt  
Verwendung für: / applicable for:  
RENAULT

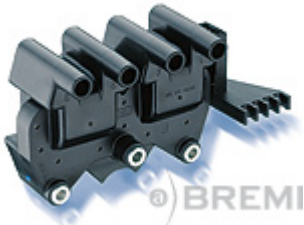

**11929**  
12 Volt  
Verwendung für: / applicable for:  
FIAT  
LANCIA



**20110**  
12 Volt  
Verwendung für: / applicable for:  
BMW  
BMW (BRILLIANCE)  
ROLLS-ROYCE



**11930**  
12 Volt  
Verwendung für: / applicable for:  
RENAULT  
VOLVO



**20111**  
12 Volt  
Verwendung für: / applicable for:  
DACIA  
NISSAN  
OPEL  
RENAULT  
VAUXHALL



**11931**  
12 Volt  
Verwendung für: / applicable for:  
RENAULT  
VOLVO



**20112**  
Empfehlung:  
20113/40 mit verwenden  
Recommendation:  
20113/40 with use  
12 Volt  
Verwendung für: / applicable for:  
AUDI  
BENTLEY  
FAW-AUDI  
VW



**20113**  
 Empfehlung:  
 20113/40 mit verwenden  
 Recommendation:  
 20113/40 with use

12 Volt

Verwendung für: / applicable for:  
 AUDI  
 SEAT  
 SKODA  
 VW



20113/40  
 12 Volt

Verwendung für: / applicable for:  
 AUDI  
 SEAT  
 SKODA  
 VW



**20114**  
 Empfehlung:  
 20113/40 mit verwenden  
 Recommendation:  
 20113/40 with use

12 Volt

Verwendung für: / applicable for:  
 AUDI  
 AUDI (FAW)  
 VW



**20115**  
 Empfehlung:  
 20113/40 mit verwenden  
 Recommendation:  
 20113/40 with use

12 Volt

Verwendung für: / applicable for:  
 AUDI  
 VW



**20116**  
 Empfehlung:  
 20113/40 mit verwenden  
 Recommendation:  
 20113/40 with use

12 Volt

Verwendung für: / applicable for:  
 SEAT  
 SKODA  
 VW



**20117**  
 Empfehlung:  
 20113/40 mit verwenden  
 Recommendation:  
 20113/40 with use

12 Volt

Verwendung für: / applicable for:  
 AUDI  
 SEAT  
 SKODA  
 SVW  
 VW



**20120**  
 Empfehlung:  
 20113/40 mit verwenden  
 Recommendation:  
 20113/40 with use

12 Volt

Verwendung für: / applicable for:  
 AUDI  
 SEAT  
 SKODA  
 VW



**20121**  
 Empfehlung:  
 20113/40 mit verwenden  
 Recommendation:  
 20113/40 with use

12 Volt

Verwendung für: / applicable for:  
 FORD  
 SEAT  
 VW



**20122**  
 Empfehlung:  
 20113/40 mit verwenden  
 Recommendation:  
 20113/40 with use

12 Volt

Verwendung für: / applicable for:  
 AUDI  
 PORSCHE  
 SEAT  
 VW



**20124**  
 Empfehlung:  
 20113/40 mit verwenden  
 Recommendation:  
 20113/40 with use

12 Volt

Verwendung für: / applicable for:  
 VW



**20125**  
 Empfehlung:  
 20113/40 mit verwenden  
 Recommendation:  
 20113/40 with use  
 12 Volt

Verwendung für: / applicable for:  
 AUDI  
 AUDI (FAW)



**20126**  
 Empfehlung:  
 20113/40 mit verwenden  
 Recommendation:  
 20113/40 with use  
 12 Volt

Verwendung für: / applicable for:  
 AUDI



**20129**  
 12 Volt  
 Verwendung für: / applicable for:  
 SKODA  
 VW



**20130**  
 12 Volt  
 Verwendung für: / applicable for:  
 AUDI  
 SEAT  
 VW



**20131**  
 12 Volt  
 Verwendung für: / applicable for:  
 NISSAN



**20132**  
 12 Volt  
 Verwendung für: / applicable for:  
 FORD  
 MERCEDES-BENZ  
 VW



**20133**  
 12 Volt  
 Verwendung für: / applicable for:  
 SEAT  
 VW



**20135**  
 12 Volt  
 Verwendung für: / applicable for:  
 HYUNDAI  
 KIA



**20136**  
 12 Volt  
 Verwendung für: / applicable for:  
 HOLDEN  
 OPEL  
 VAUXHALL



**20137**  
 12 Volt  
 Verwendung für: / applicable for:  
 HYUNDAI  
 MITSUBISHI



**20138**  
 12 Volt  
 Verwendung für: / applicable for:  
 CHEVROLET  
 DAEWOO  
 OPEL



**20139**  
 12 Volt  
 Verwendung für: / applicable for:  
 FORD



**20140**  
12 Volt

Verwendung für: / applicable for:  
HONDA  
ROVER



**20146**  
12 Volt

Verwendung für: / applicable for:  
AUDI



**20141**  
12 Volt

Verwendung für: / applicable for:  
HYUNDAI  
KIA  
MITSUBISHI  
NISSAN



**20147**  
12 Volt

Verwendung für: / applicable for:  
OPEL



**20142**  
12 Volt

Verwendung für: / applicable for:  
RENAULT



**20148**  
12 Volt

Verwendung für: / applicable for:  
LEXUS  
TOYOTA



**20143**  
12 Volt

Verwendung für: / applicable for:  
HYUNDAI



**20149**  
12 Volt

Verwendung für: / applicable for:  
INFINITI  
NISSAN



**20144**  
12 Volt

Verwendung für: / applicable for:  
VW



**20150**  
12 Volt

Verwendung für: / applicable for:  
SUZUKI



**20145**  
12 Volt

Verwendung für: / applicable for:  
MERCEDES-BENZ



**20151**  
12 Volt

Verwendung für: / applicable for:  
SUZUKI



**20152**  
12 Volt

Verwendung für: / applicable for:  
TOYOTA



**20153**  
12 Volt

Verwendung für: / applicable for:  
MERCEDES-BENZ



**20154**  
12 Volt

Verwendung für: / applicable for:  
JAGUAR



**20155**

Empfehlung: 20155/17 mit verwenden  
Recommendation: 20155/17 with use

12 Volt

Verwendung für: / applicable for:  
FORD  
FORD USA  
MAZDA



**20156**  
12 Volt

Verwendung für: / applicable for:  
CITROEN  
PEUGEOT



**20157**  
12 Volt

Verwendung für: / applicable for:  
SMART



**20158**  
12 Volt

Verwendung für: / applicable for:  
HONDA



**20159**  
12 Volt

Verwendung für: / applicable for:  
AUDI



**20160**  
12 Volt

Verwendung für: / applicable for:  
CHEVROLET  
OPEL  
VAUXHALL



**20161**  
12 Volt

Verwendung für: / applicable for:  
CITROEN  
PEUGEOT



**20162**  
12 Volt

Verwendung für: / applicable for:  
TOYOTA



**20163**  
12 Volt

Verwendung für: / applicable for:  
TOYOTA



**20164**  
12 Volt  
Verwendung für: / applicable for:  
HYUNDAI



**20170**  
12 Volt  
Verwendung für: / applicable for:  
HYUNDAI



**20165**  
12 Volt  
Verwendung für: / applicable for:  
DAIHATSU



**20171**  
12 Volt  
Verwendung für: / applicable for:  
NISSAN



**20166**  
12 Volt  
Verwendung für: / applicable for:  
CHEVROLET  
DAEWOO  
OPEL  
VAUXHALL



**20172**  
12 Volt  
Verwendung für: / applicable for:  
LAND ROVER  
MG  
ROVER



**20167**  
12 Volt  
Verwendung für: / applicable for:  
RENAULT



**20173**  
12 Volt  
Verwendung für: / applicable for:  
HYUNDAI

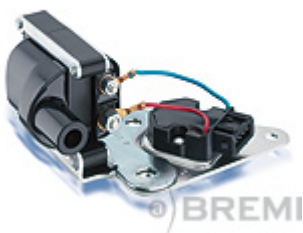

**20168**  
12 Volt  
Verwendung für: / applicable for:  
RENAULT  
VOLVO



**20174**  
12 Volt  
Verwendung für: / applicable for:  
ALFA ROMEO



**20169**  
12 Volt  
Verwendung für: / applicable for:  
OPEL  
VAUXHALL



**20175**  
12 Volt  
Verwendung für: / applicable for:  
ALFA ROMEO





**20176**  
12 Volt  
Verwendung für: / applicable for:  
FORD  
FORD ASIA  
VOLVO



**20182**  
12 Volt  
Verwendung für: / applicable for:  
CITROEN  
PEUGEOT



**20177**  
12 Volt  
Verwendung für: / applicable for:  
DAIMLER  
FORD  
JAGUAR



**20183**  
12 Volt  
Verwendung für: / applicable for:  
CITROEN  
PEUGEOT



**20178**  
12 Volt  
Verwendung für: / applicable for:  
OPEL  
SAAB  
VAUXHALL



**20184**  
12 Volt  
Verwendung für: / applicable for:  
OPEL  
VAUXHALL



**20179**  
12 Volt  
Verwendung für: / applicable for:  
OPEL  
VAUXHALL



**20185**  
12 Volt  
Verwendung für: / applicable for:  
MERCEDES-BENZ  
MERCEDES-BENZ (BBDC)



**20180**  
12 Volt  
Verwendung für: / applicable for:  
MERCEDES-BENZ



**20186**  
12 Volt  
Verwendung für: / applicable for:  
LANCIA  
VOLVO



**20181**  
12 Volt  
Verwendung für: / applicable for:  
FERRARI  
OPEL  
SAAB  
VAUXHALL



**20187**  
12 Volt  
Verwendung für: / applicable for:  
FIAT  
LANCIA



**20188**  
12 Volt  
Verwendung für: / applicable for:  
MERCEDES-BENZ



**20194**  
12 Volt  
Verwendung für: / applicable for:  
LOTUS  
ROVER



**20189**  
12 Volt  
Verwendung für: / applicable for:  
OPEL  
VAUXHALL



**20195**  
12 Volt  
Verwendung für: / applicable for:  
MERCEDES-BENZ



**20190**  
12 Volt  
Verwendung für: / applicable for:  
FORD



**20196**  
12 Volt  
Verwendung für: / applicable for:  
TOYOTA



**20191**  
12 Volt  
Verwendung für: / applicable for:  
SCION  
TOYOTA



**20197**  
12 Volt  
Verwendung für: / applicable for:  
FIAT  
LANCIA



**20192**  
12 Volt  
Verwendung für: / applicable for:  
INFINITI  
NISSAN



**20198**  
12 Volt  
Verwendung für: / applicable for:  
FIAT  
SUBARU  
SUZUKI



**20193**  
12 Volt  
Verwendung für: / applicable for:  
HOLDEN  
OPEL  
SAAB  
VAUXHALL



**20199**  
12 Volt  
Verwendung für: / applicable for:  
MERCEDES-BENZ



**20200**  
12 Volt  
Verwendung für: / applicable for:  
RENAULT



**20306**  
12 Volt  
Verwendung für: / applicable for:  
CITROEN  
FIAT  
LANCIA  
PEUGEOT  
RENAULT



**20300**  
12 Volt  
Verwendung für: / applicable for:  
DAEWOO

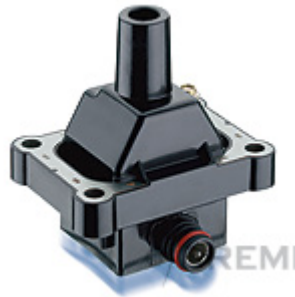

**20307**  
12 Volt  
Verwendung für: / applicable for:  
DAEWOO  
MERCEDES-BENZ  
PUCH  
SSANGYONG  
VW



**20301**  
12 Volt  
Verwendung für: / applicable for:  
LEXUS  
TOYOTA  
VW



**20308**  
12 Volt  
Verwendung für: / applicable for:  
DAIHATSU  
MITSUBISHI

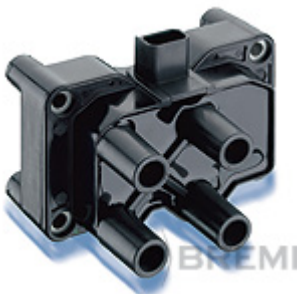

**20303**  
12 Volt  
Verwendung für: / applicable for:  
FORD



**20309**  
12 Volt  
Verwendung für: / applicable for:  
SUZUKI



**20304**  
12 Volt  
Verwendung für: / applicable for:  
HYUNDAI



**20310**  
12 Volt  
Verwendung für: / applicable for:  
OPEL  
VAUXHALL



**20305**  
12 Volt  
Verwendung für: / applicable for:  
SUBARU



**20311**  
12 Volt  
Verwendung für: / applicable for:  
OPEL  
VAUXHALL



**20312**  
12 Volt  
Verwendung für: / applicable for:  
ALFA ROMEO  
LANCIA



**20318**  
12 Volt  
Verwendung für: / applicable for:  
NISSAN



**20313**  
12 Volt  
Verwendung für: / applicable for:  
FORD  
VOLVO



**20319**  
12 Volt  
Verwendung für: / applicable for:  
MERCEDES-BENZ  
PORSCHE



**20314**  
12 Volt  
Verwendung für: / applicable for:  
TOYOTA



**20320**  
12 Volt  
Verwendung für: / applicable for:  
CITROEN  
PEUGEOT



**20315**  
12 Volt  
Verwendung für: / applicable for:  
KIA



**20321**  
12 Volt  
Verwendung für: / applicable for:  
OPEL  
VAUXHALL



**20316**  
12 Volt  
Verwendung für: / applicable for:  
CITROEN  
PEUGEOT



**20322**  
12 Volt  
Verwendung für: / applicable for:  
NISSAN



**20317**  
12 Volt  
Verwendung für: / applicable for:  
HYUNDAI  
KIA



**20323**  
12 Volt  
Verwendung für: / applicable for:  
CHEVROLET  
CITROEN  
PEUGEOT  
PONTIAC  
TOYOTA



**20324**  
12 Volt

Verwendung für: / applicable for:  
NISSAN



**20331**

Empfehlung:  
20113/40 mit verwenden  
Recommendation:  
20113/40 with use

12 Volt

Verwendung für: / applicable for:  
AUDI  
SKODA  
VW



**20325**  
12 Volt

Verwendung für: / applicable for:  
NISSAN



**20332**  
12 Volt

Verwendung für: / applicable for:  
TOYOTA



**20326**  
12 Volt

Verwendung für: / applicable for:  
HYUNDAI  
KIA



**20333**  
12 Volt

Verwendung für: / applicable for:  
ACURA  
HONDA



**20327**  
12 Volt

Verwendung für: / applicable for:  
MERCEDES-BENZ



**20334**  
12 Volt

Verwendung für: / applicable for:  
CITROEN  
PEUGEOT



**20328**  
12 Volt

Verwendung für: / applicable for:  
NISSAN



**20335**  
12 Volt

Verwendung für: / applicable for:  
OPEL  
VAUXHALL



**20329**  
12 Volt

Verwendung für: / applicable for:  
FORD  
FORD USA



**20336**  
12 Volt

Verwendung für: / applicable for:  
FIAT  
LANCIA



**20337**  
12 Volt  
Verwendung für: / applicable for:  
NISSAN



**20345**  
12 Volt  
Verwendung für: / applicable for:  
DACIA  
RENAULT



**20338**  
12 Volt  
Verwendung für: / applicable for:  
ALFA ROMEO



**20346**  
12 Volt  
Verwendung für: / applicable for:  
TOYOTA



**20339**  
12 Volt  
Verwendung für: / applicable for:  
HYUNDAI  
KIA



**20347**  
12 Volt  
Verwendung für: / applicable for:  
RENAULT



**20340**  
12 Volt  
Verwendung für: / applicable for:  
CITROEN  
FIAT  
LANCIA  
PEUGEOT



**20348**  
12 Volt  
Verwendung für: / applicable for:  
RENAULT



**20341**  
12 Volt  
Verwendung für: / applicable for:  
CHRYSLER  
DODGE  
PLYMOUTH



**20349**  
12 Volt  
Verwendung für: / applicable for:  
TOYOTA



**20344**  
12 Volt  
Verwendung für: / applicable for:  
HYUNDAI  
KIA

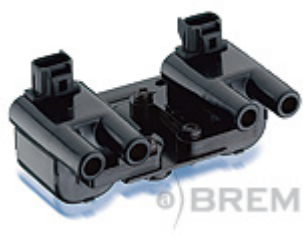

**20350**  
12 Volt  
Verwendung für: / applicable for:  
CHEVROLET  
DAEWOO



**20351**  
12 Volt

Verwendung für: / applicable for:  
CHRYSLER  
MITSUBISHI



**20357**  
12 Volt

Verwendung für: / applicable for:  
HYUNDAI  
KIA



**20352**  
12 Volt

Verwendung für: / applicable for:  
CITROEN  
PEUGEOT  
RENAULT



**20358**  
12 Volt

Verwendung für: / applicable for:  
CHRYSLER  
DODGE  
JEEP



**20353**  
12 Volt

Verwendung für: / applicable for:  
MAZDA



**20359**  
12 Volt

Verwendung für: / applicable for:  
HYUNDAI  
KIA



**20354**  
12 Volt

Verwendung für: / applicable for:  
MITSUBISHI



**20361**  
12 Volt

Verwendung für: / applicable for:  
KIA



**20355**  
12 Volt

Verwendung für: / applicable for:  
MITSUBISHI



**20362**  
12 Volt

Verwendung für: / applicable for:  
TOYOTA



**20356**  
12 Volt

Verwendung für: / applicable for:  
CHRYSLER



**20363**  
12 Volt

Verwendung für: / applicable for:  
VW



**20364**  
12 Volt  
Verwendung für: / applicable for:  
VOLVO



**20370**  
12 Volt  
Verwendung für: / applicable for:  
HONDA



**20365**  
12 Volt  
Verwendung für: / applicable for:  
CADILLAC  
OPEL  
VAUXHALL



**20371**  
12 Volt  
Verwendung für: / applicable for:  
SKODA



**20366**  
12 Volt  
Verwendung für: / applicable for:  
AUDI



**20372**  
12 Volt  
Verwendung für: / applicable for:  
CHRYSLER  
JEEP  
MINI  
MITSUBISHI

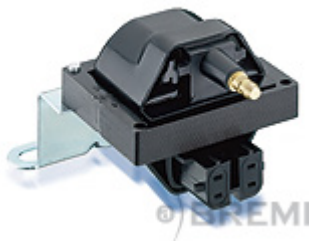

**20367**  
12 Volt  
Verwendung für: / applicable for:  
DAEWOO



**20373**  
12 Volt  
Verwendung für: / applicable for:  
CITROEN  
PEUGEOT



**20368**  
12 Volt  
Verwendung für: / applicable for:  
CADILLAC  
OPEL  
VAUXHALL



**20374**  
12 Volt  
Verwendung für: / applicable for:  
VOLVO



**20369**  
12 Volt  
Verwendung für: / applicable for:  
KIA



**20375**  
12 Volt  
Verwendung für: / applicable for:  
PORSCH





**20376**  
12 Volt  
Verwendung für: / applicable for:  
HYUNDAI  
KIA



**20382**  
12 Volt  
Verwendung für: / applicable for:  
FIAT



**20377**  
12 Volt  
Verwendung für: / applicable for:  
CITROEN  
PEUGEOT



**20383**  
12 Volt  
Verwendung für: / applicable for:  
CITROEN  
PEUGEOT



**20378**  
12 Volt  
Verwendung für: / applicable for:  
HYUNDAI  
KIA



**20384**  
12 Volt  
Verwendung für: / applicable for:  
CHRYSLER  
DODGE  
JEEP



**20379**  
12 Volt  
Verwendung für: / applicable for:  
MAZDA



**20385**  
12 Volt  
Verwendung für: / applicable for:  
TOYOTA



**20380**  
12 Volt  
Verwendung für: / applicable for:  
FIAT



**20386**  
12 Volt  
Verwendung für: / applicable for:  
PONTIAC  
TOYOTA



**20381**  
12 Volt  
Verwendung für: / applicable for:  
LADA



**20387**  
12 Volt  
Verwendung für: / applicable for:  
LADA



**20388**  
12 Volt

Verwendung für: / applicable for:  
HYUNDAI  
KIA



**20394**  
12 Volt

Verwendung für: / applicable for:  
NISSAN



**20389**  
12 Volt

Verwendung für: / applicable for:  
HYUNDAI  
KIA



**20395**  
12 Volt

Verwendung für: / applicable for:  
HYUNDAI



**20390**  
12 Volt

Verwendung für: / applicable for:  
NISSAN



**20396**  
12 Volt

Verwendung für: / applicable for:  
LEXUS  
TOYOTA



**20391**  
12 Volt

Verwendung für: / applicable for:  
CHRYSLER  
DODGE

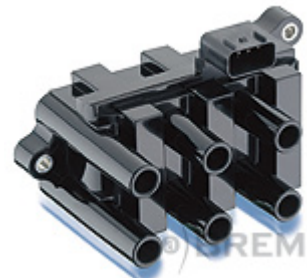

**20397**  
12 Volt

Verwendung für: / applicable for:  
FORD  
FORD USA  
MAZDA  
MERCURY



**20392**  
12 Volt

Verwendung für: / applicable for:  
FORD  
FORD USA  
LINCOLN  
MERCURY



**20398**  
12 Volt

Verwendung für: / applicable for:  
LEXUS  
TOYOTA



**20393**  
12 Volt

Verwendung für: / applicable for:  
FORD  
FORD USA  
LINCOLN  
MERCURY



**20399**  
12 Volt

Verwendung für: / applicable for:  
SUBARU



**20400**  
12 Volt  
Verwendung für: / applicable for:  
HONDA



**20406**  
12 Volt  
Verwendung für: / applicable for:  
MAZDA



**20401**  
12 Volt  
Verwendung für: / applicable for:  
HONDA



**20407**  
12 Volt  
Verwendung für: / applicable for:  
CHRYSLER  
DODGE  
PLYMOUTH



**20402**  
12 Volt  
Verwendung für: / applicable for:  
LEXUS  
TOYOTA



**20408**  
12 Volt  
Verwendung für: / applicable for:  
FORD USA  
MAZDA



**20403**  
12 Volt  
Verwendung für: / applicable for:  
HONDA



**20409**  
12 Volt  
Verwendung für: / applicable for:  
MITSUBISHI



**20404**  
12 Volt  
Verwendung für: / applicable for:  
CADILLAC  
CHEVROLET  
GMC



**20410**  
12 Volt  
Verwendung für: / applicable for:  
CHEVROLET  
GMC



**20405**  
12 Volt  
Verwendung für: / applicable for:  
CHRYSLER



**20411**  
12 Volt  
Verwendung für: / applicable for:  
NISSAN



**20412**  
12 Volt

Verwendung für: / applicable for:  
FIAT  
LANCIA



**20418**  
12 Volt

Verwendung für: / applicable for:  
BUICK  
CHEVROLET  
GMC  
HUMMER  
ISUZU  
OLDSMOBILE  
SAAB

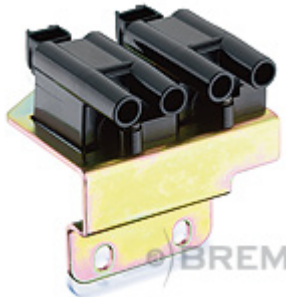

**20413**  
12 Volt

Verwendung für: / applicable for:  
IRAN KHODRO



**20420**  
12 Volt

Verwendung für: / applicable for:  
VW



**20414**  
12 Volt

Verwendung für: / applicable for:  
HONDA



**20421**  
12 Volt

Verwendung für: / applicable for:  
JEEP



**20415**  
12 Volt

Verwendung für: / applicable for:  
DAIHATSU  
TOYOTA



**20422**  
12 Volt

Verwendung für: / applicable for:  
CADILLAC  
CHEVROLET  
PONTIAC



**20416**  
12 Volt

Verwendung für: / applicable for:  
LAND ROVER  
MG  
ROVER



**20423**  
12 Volt

Verwendung für: / applicable for:  
BUICK  
CHEVROLET  
PONTIAC



**20417**  
12 Volt

Verwendung für: / applicable for:  
CHRYSLER  
DODGE  
JEEP



**20424**  
12 Volt

Verwendung für: / applicable for:  
CADILLAC  
CHEVROLET  
GMC



**20425**  
12 Volt

Verwendung für: / applicable for:  
CADILLAC  
CHEVROLET  
ISUZU  
OPEL  
VAUXHALL

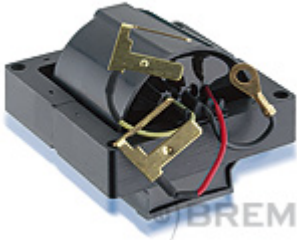

**20426**  
12 Volt

Verwendung für: / applicable for:  
BUICK  
CADILLAC  
CHEVROLET

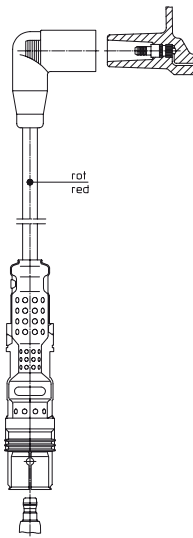

1A01/ 58  
 1A01/ 66  
 1A01/ 77  
 1A01/ 80  
 Verwendung für: /  
 applicable for:  
 VW

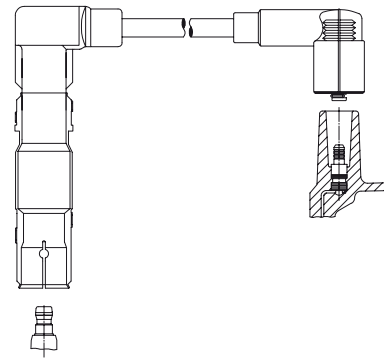

1A03/ 26  
 1A03/ 39  
 1A03/ 44  
 1A03/ 58  
 Verwendung für: /  
 applicable for:  
 VW

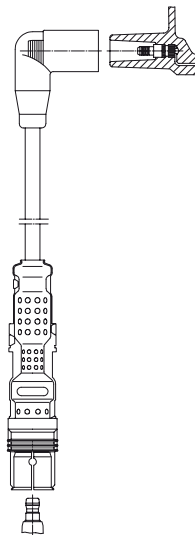

1A02/ 61  
 1A02/ 70  
 Verwendung für: /  
 applicable for:  
 SEAT  
 SKODA  
 VW

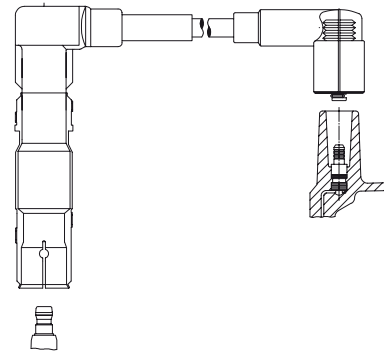

1A03E 66  
 Verwendung für: /  
 applicable for:  
 VW

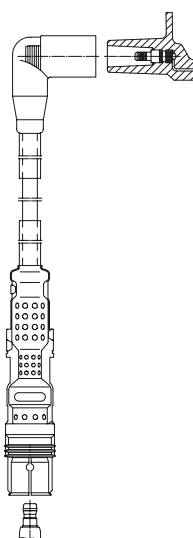

1A02F 37  
 1A02F 43  
 1A02F 49  
 1A02F 50  
 1A02F 57  
 1A02F 59  
 1A02F 63  
 1A02F 67  
 1A02F 72  
 1A02F 85  
 Verwendung für: /  
 applicable for:  
 SEAT  
 SKODA  
 VW

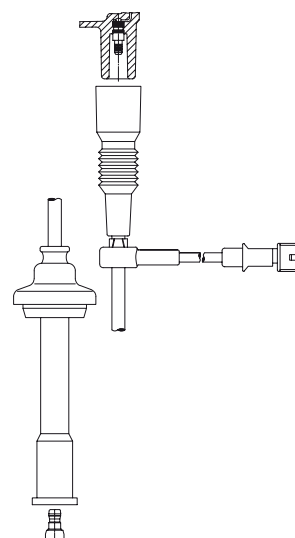

1A04/100  
 Verwendung für: /  
 applicable for:  
 ALFA ROMEO

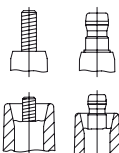

Connection spark plug: M4, SAE

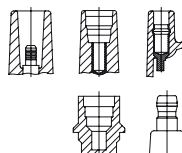

Connection distr. cap/ign. coil: 4 mm, Toyota 5 mm, DIN



Connection distributor cap: M4, SAE



Connection distr. cap/ign. coil: Ford, SAE



1A05/ 73  
1A05/ 85  
1A05/108  
Verwendung für: /  
applicable for:  
ALFA ROMEO

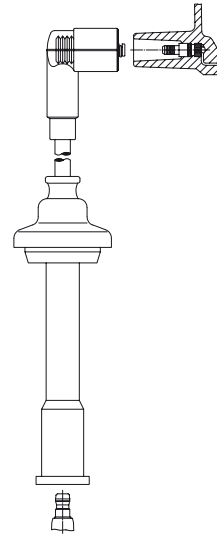

1A08/ 63  
1A08/ 70  
1A08/ 80  
1A08/ 85  
1A08/ 88  
1A08/ 90  
1A08/ 93  
1A08/ 97  
1A08/100  
1A08/105  
1A08/110  
Verwendung für: /  
applicable for:  
ALFA ROMEO  
FIAT  
LANCIA

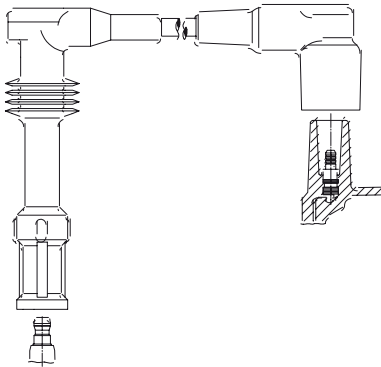

1A06/ 50  
1A06/ 58  
1A06/ 72  
Verwendung für: /  
applicable for:  
ALFA ROMEO

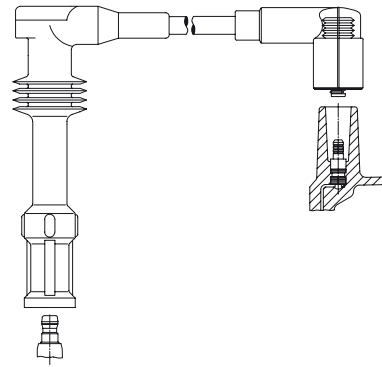

1A09/ 32  
1A09/ 48  
1A09/ 60  
Verwendung für: /  
applicable for:  
ALFA ROMEO

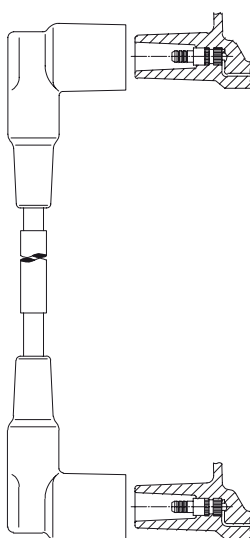

1A07E 25  
Verwendung für: /  
applicable for:  
ALFA ROMEO

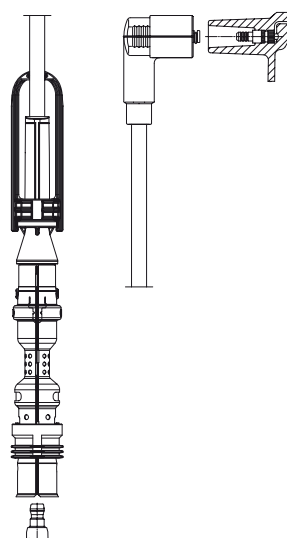

1A10/ 72  
1A10/ 85  
1A10/ 88  
1A10/100  
Verwendung für: /  
applicable for:  
VW

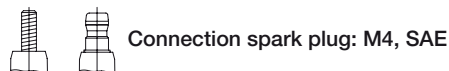

Connection spark plug: M4, SAE

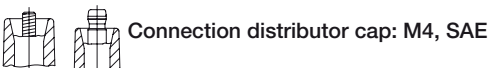

Connection distributor cap: M4, SAE

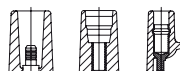

Connection distr. cap/ign. coil: 4 mm, Toyota 5 mm, DIN



Connection distr. cap/ign. coil: Ford, SAE

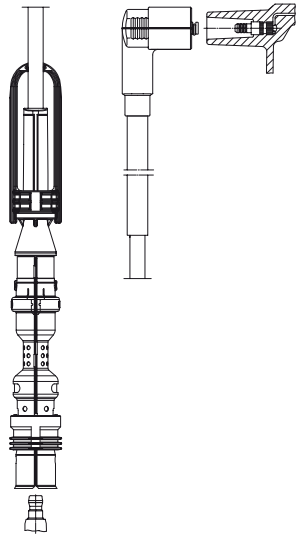

1A10E 58  
1A10E 73  
Verwendung für: /  
applicable for:  
VW

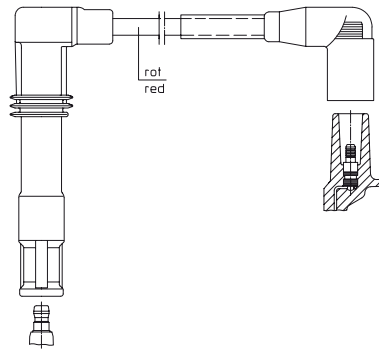

1A12E 43  
1A12E 47  
Verwendung für: /  
applicable for:  
SEAT  
SKODA  
VW

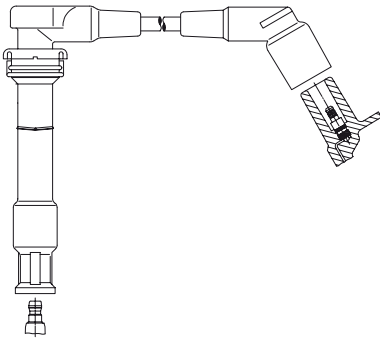

1A11/ 40  
1A11/ 42  
1A11/ 63  
Verwendung für: /  
applicable for:  
ROVER

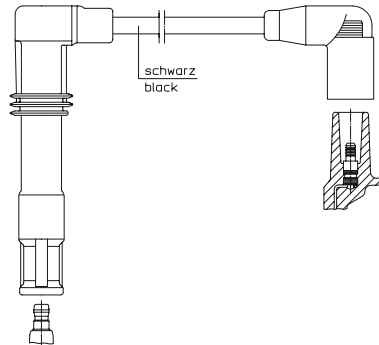

1A13/ 26  
1A13/ 33  
Verwendung für: /  
applicable for:  
AUDI  
SEAT  
SKODA  
VW

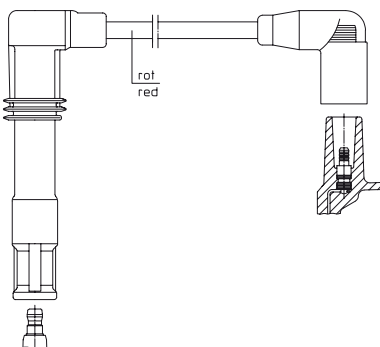

1A12/ 26  
1A12/ 33  
Verwendung für: /  
applicable for:  
SEAT  
SKODA  
VW

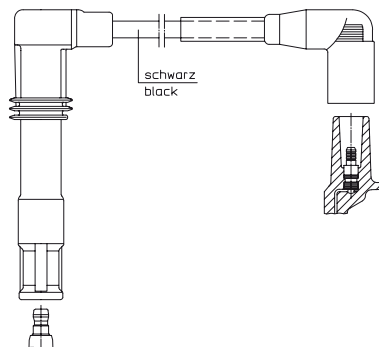

1A13E 43  
1A13E 47  
Verwendung für: /  
applicable for:  
AUDI  
SEAT  
SKODA  
VW

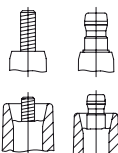

Connection spark plug: M4, SAE

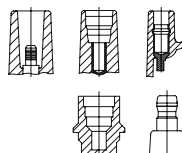

Connection distr. cap/ign. coil: 4 mm, Toyota 5 mm, DIN

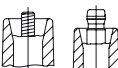

Connection distributor cap: M4, SAE



Connection distr. cap/ign. coil: Ford, SAE



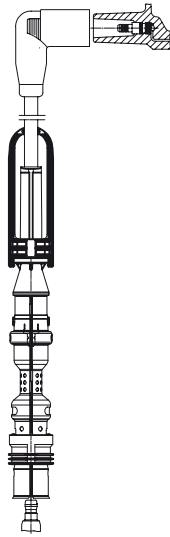

1A14/ 58  
 1A14/ 65  
 1A14/ 66  
 1A14/ 77  
 1A14/ 79  
 Verwendung für: /  
 applicable for:  
 SEAT  
 VW

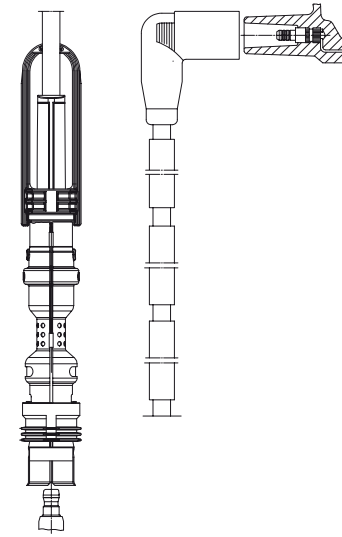

1A15H 86  
 Verwendung für: /  
 applicable for:  
 VW

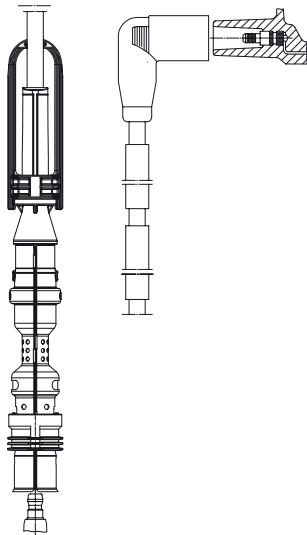

1A14F 57  
 1A14F 66  
 Verwendung für: /  
 applicable for:  
 VW

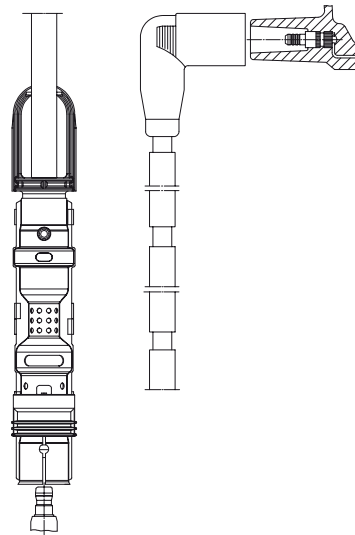

1A16H 73  
 Verwendung für: /  
 applicable for:  
 VW

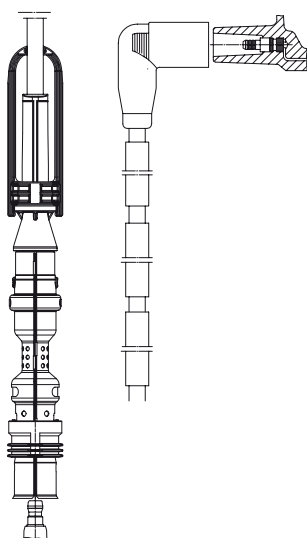

1A14H 71  
 Verwendung für: /  
 applicable for:  
 VW

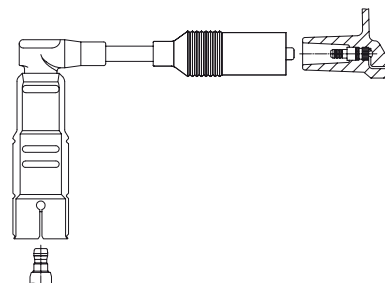

1A17/ 58  
 1A17/ 68  
 1A17/ 76  
 1A17/ 83  
 Verwendung für: /  
 applicable for:  
 ALFA ROMEO

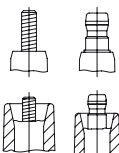

Connection spark plug: M4, SAE

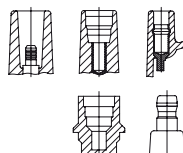

Connection distr. cap/ign. coil: 4 mm, Toyota 5 mm, DIN



Connection distributor cap: M4, SAE



Connection distr. cap/ign. coil: Ford, SAE

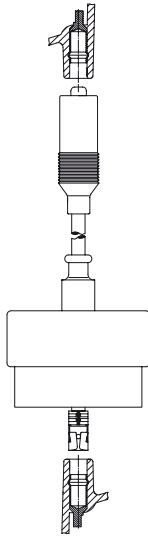

1A18/ 78  
Verwendung für: /  
applicable for:  
ALFA ROMEO

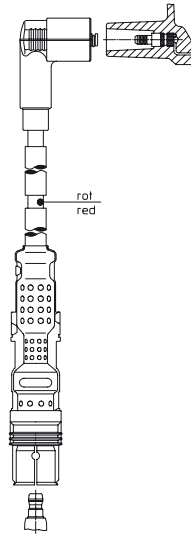

1A21E 68  
1A21E 69  
1A21E 85  
1A21E 86  
1A21E 97  
Verwendung für: /  
applicable for:  
VW

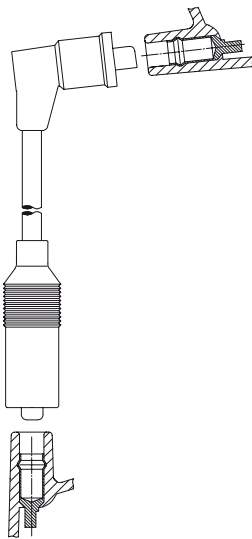

1A19/ 50  
Verwendung für: /  
applicable for:  
ALFA ROMEO

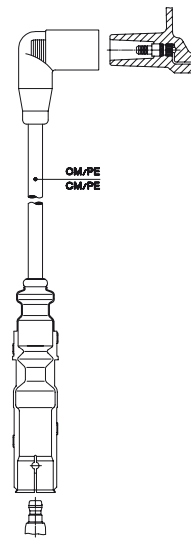

1A22/ 46  
Verwendung für: /  
applicable for:  
AUDI  
VW

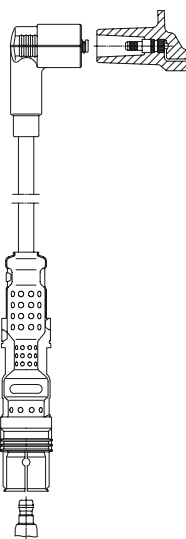

1A21/ 54  
Verwendung für: /  
applicable for:  
VW

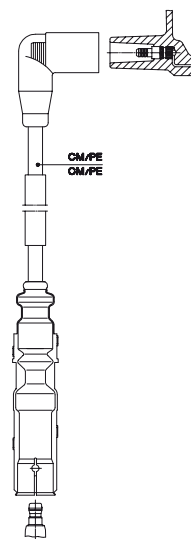

1A22E 26  
1A22E 65  
Verwendung für: /  
applicable for:  
AUDI  
VW

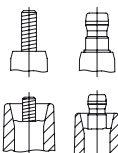

Connection spark plug: M4, SAE

Connection distributor cap: M4, SAE

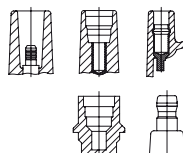

Connection distr. cap/ign. coil: 4 mm, Toyota 5 mm, DIN

Connection distr. cap/ign. coil: Ford, SAE

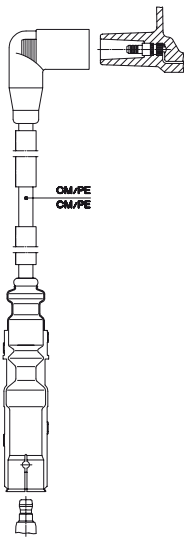

1A22F 64  
Verwendung für: /  
applicable for:  
AUDI  
VW

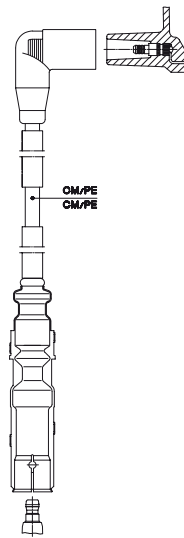

1A23F 61  
Verwendung für: /  
applicable for:  
AUDI  
SEAT  
VW

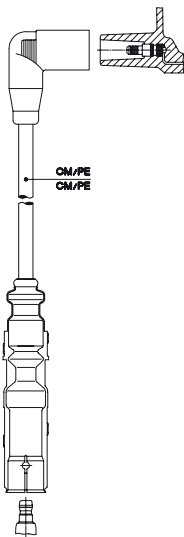

1A23/ 46  
Verwendung für: /  
applicable for:  
AUDI  
SEAT  
VW

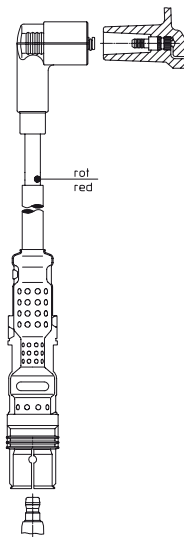

1A24E 52  
1A24E 69  
1A24E 86  
Verwendung für: /  
applicable for:  
VW

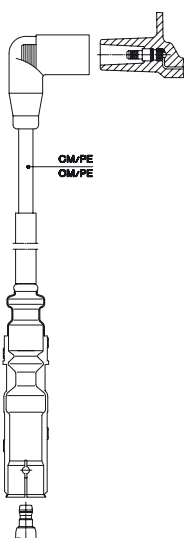

1A23E 26  
1A23E 65  
Verwendung für: /  
applicable for:  
AUDI  
SEAT  
VW

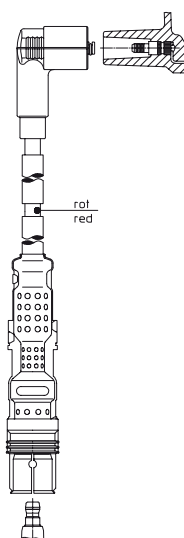

1A24F 92  
1A24F 99  
1A24F100  
Verwendung für: /  
applicable for:  
VW

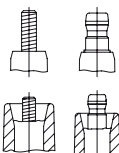

Connection spark plug: M4, SAE

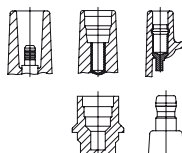

Connection distr. cap/ign. coil: 4 mm, Toyota 5 mm, DIN



Connection distributor cap: M4, SAE



Connection distr. cap/ign. coil: Ford, SAE

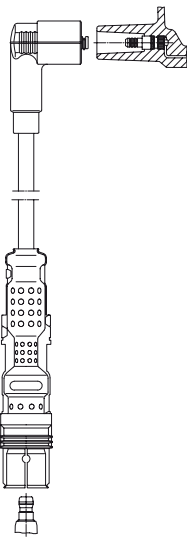

1A25/ 52  
1A25/ 70  
1A25/ 89  
Verwendung für: /  
applicable for:  
MERCEDES-BENZ

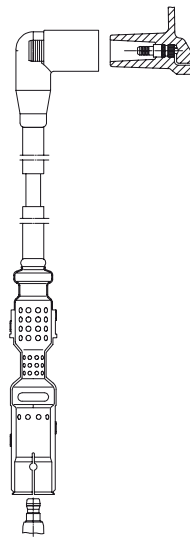

1A28F 59  
1A28F 85  
Verwendung für: /  
applicable for:  
SEAT  
VW

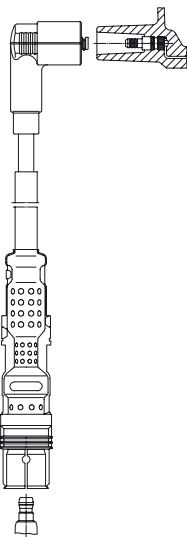

1A25E 95  
1A25E108  
1A25E110  
Verwendung für: /  
applicable for:  
MERCEDES-BENZ

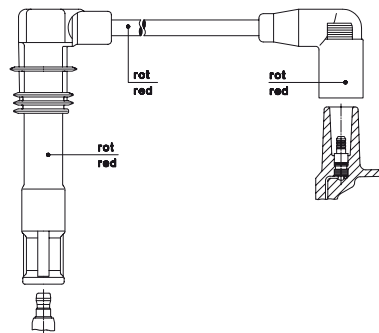

1A30/ 25  
1A30/ 33  
Verwendung für: /  
applicable for:  
SEAT  
VW

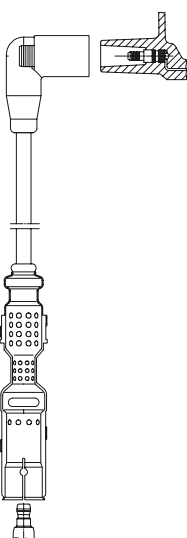

1A28/ 61  
1A28/ 70  
Verwendung für: /  
applicable for:  
SEAT  
VW

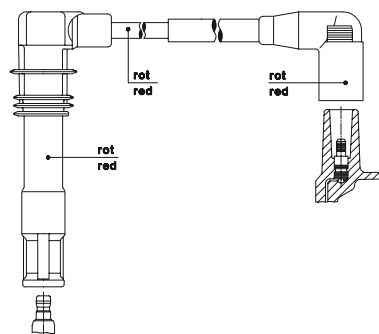

1A30E 43  
1A30E 47  
Verwendung für: /  
applicable for:  
SEAT  
VW

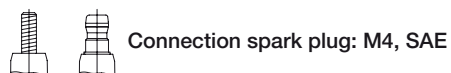

Connection spark plug: M4, SAE

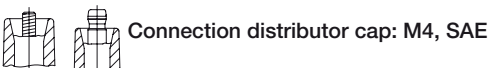

Connection distributor cap: M4, SAE

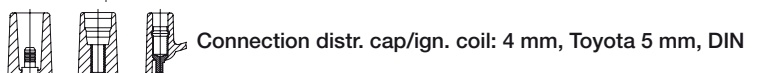

Connection distr. cap/ign. coil: 4 mm, Toyota 5 mm, DIN

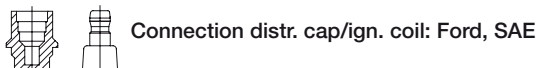

Connection distr. cap/ign. coil: Ford, SAE

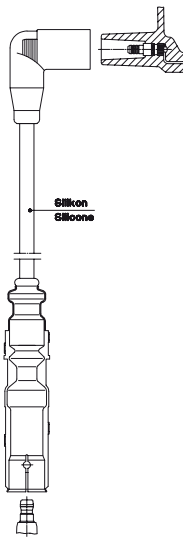

1A32/ 25  
1A32/ 27  
Verwendung für: /  
applicable for:  
AUDI  
SEAT  
SKODA  
SVW  
VW

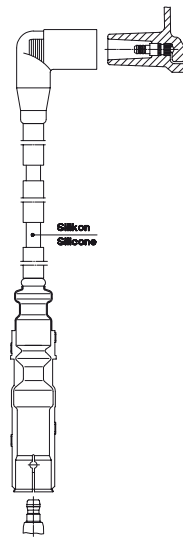

1A32H 42  
1A32H 61  
Verwendung für: /  
applicable for:  
AUDI  
SEAT  
SKODA  
SVW  
VW

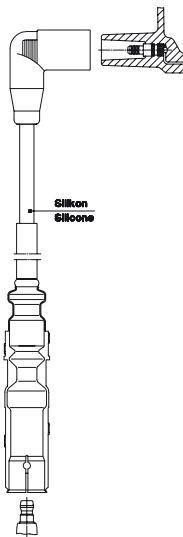

1A32E 26  
1A32E 44  
1A32E 58  
1A32E 64  
1A32E 78  
Verwendung für: /  
applicable for:  
AUDI  
SEAT  
SKODA  
SVW  
VW



1A46E 37  
1A46E 42  
1A46E 43  
1A46E 44  
Verwendung für: /  
applicable for:  
MERCEDES-BENZ

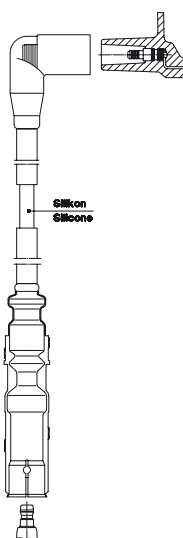

1A32F 49  
1A32F 60  
1A32F 63  
Verwendung für: /  
applicable for:  
AUDI  
SEAT  
SKODA  
VW

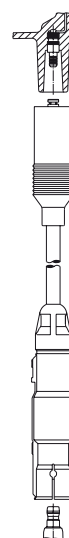

1A48/ 22  
Verwendung für: /  
applicable for:  
SMART

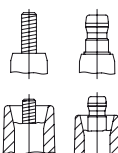

Connection spark plug: M4, SAE

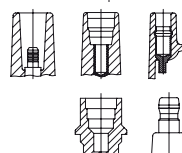

Connection distr. cap/ign. coil: 4 mm, Toyota 5 mm, DIN

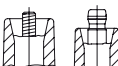

Connection distributor cap: M4, SAE



Connection distr. cap/ign. coil: Ford, SAE



1A48E 46  
Verwendung für: /  
applicable for:  
SMART

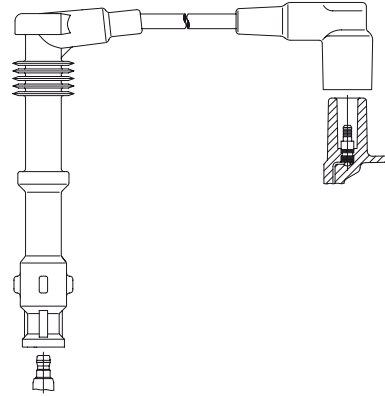

106/ 25  
106/ 50  
106/ 55  
106/ 80  
106/ 85  
106/ 90  
106/ 95  
Verwendung für: /  
applicable for:  
AUDI

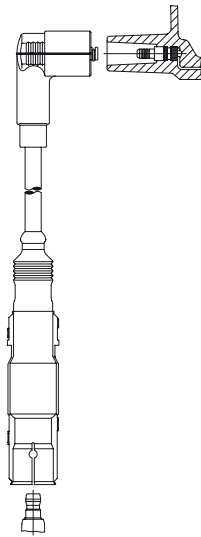

104/ 56  
104/ 62  
104/ 70  
104/ 72  
104/ 76  
104/ 86  
104/ 90  
104/ 98  
Verwendung für: /  
applicable for:  
VW

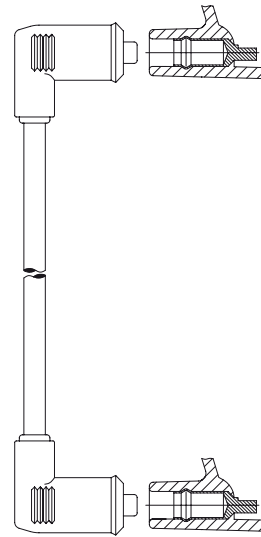

107/ 45  
Verwendung für: /  
applicable for:  
AUDI  
VW

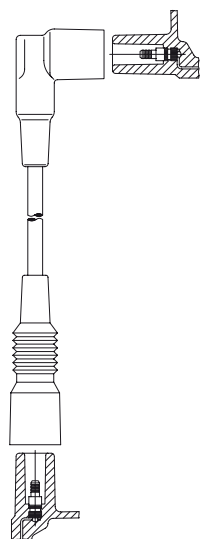

105/ 30  
Verwendung für: /  
applicable for:  
AUDI

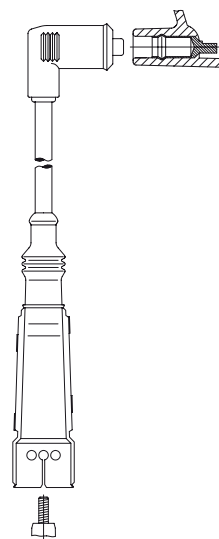

108/ 75  
Verwendung für: /  
applicable for:  
AUDI  
SEAT  
VW

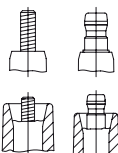

Connection spark plug: M4, SAE

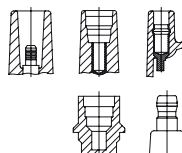

Connection distr. cap/ign. coil: 4 mm, Toyota 5 mm, DIN

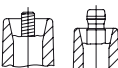

Connection distributor cap: M4, SAE



Connection distr. cap/ign. coil: Ford, SAE

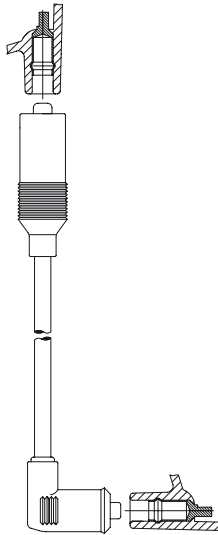

109/ 57  
109/ 65  
Verwendung für: /  
applicable for:  
AUDI  
LANCIA  
SEAT  
VW

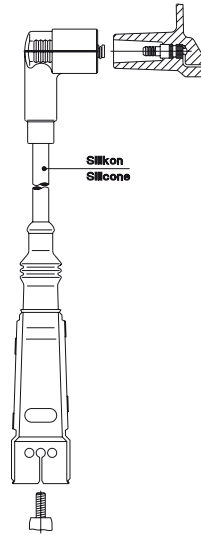

111A 33  
111A 40  
111A 47  
111A 52  
111A 55  
111A 66  
111A 70  
Verwendung für: /  
applicable for:  
SEAT  
VW

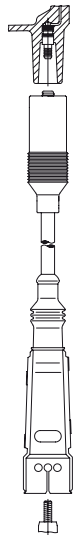

110/ 30  
110/ 35  
110/ 40  
110/ 50  
110/ 60  
110/ 70  
Verwendung für: /  
applicable for:  
AUDI  
SEAT  
VW

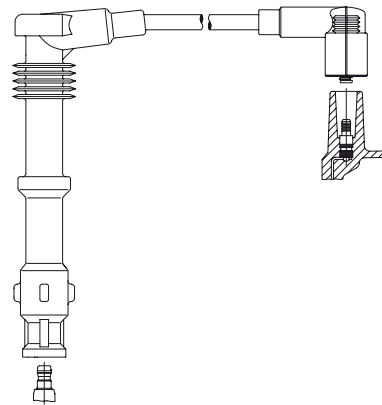

112/ 60  
112/ 75  
112/ 80  
112/ 90  
112/100  
Verwendung für: /  
applicable for:  
AUDI

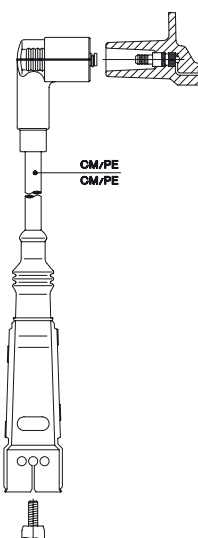

111/ 40  
111/ 50  
111/ 52  
111/ 54  
111/ 55  
111/ 60  
111/ 70  
111/ 75  
111/ 80  
111/ 82  
111/ 85  
Verwendung für: /  
applicable for:  
AUDI  
SEAT  
SKODA  
VW  
WARTBURG

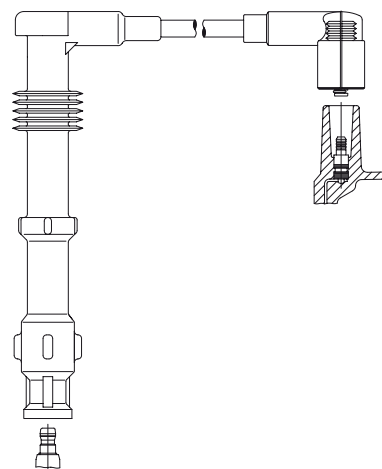

113/ 45  
113/ 50  
113/ 60  
113/ 65  
113/ 75  
113/ 80  
113/ 83  
113/ 85  
Verwendung für: /  
applicable for:  
AUDI  
SEAT  
VW

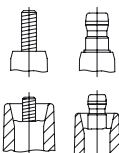

Connection spark plug: M4, SAE

Connection distributor cap: M4, SAE

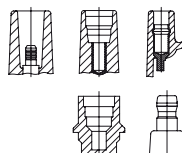

Connection distr. cap/ign. coil: 4 mm, Toyota 5 mm, DIN

Connection distr. cap/ign. coil: Ford, SAE

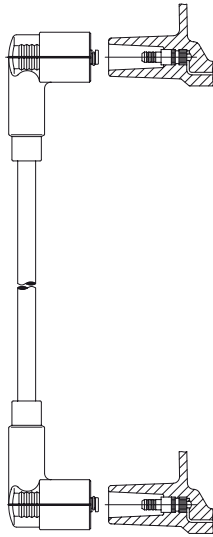

114/ 35  
 114/ 40  
 114/ 47  
 114/ 50  
 114/ 55  
 114/ 60  
 114/ 75  
 Verwendung für: /  
 applicable for:  
 AUDI  
 SEAT  
 SKODA  
 VW

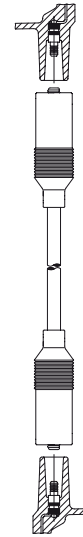

117/ 50  
 117/ 60  
 Verwendung für: /  
 applicable for:  
 SEAT  
 VW

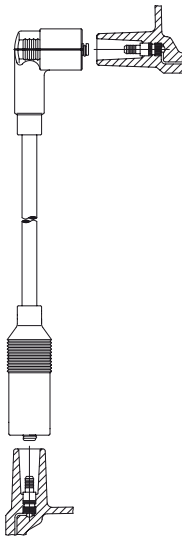

115/ 30  
 115/ 36  
 115/ 40  
 115/ 55  
 115/ 60  
 115/ 70  
 Verwendung für: /  
 applicable for:  
 AUDI  
 SEAT  
 VW  
 WARTBURG

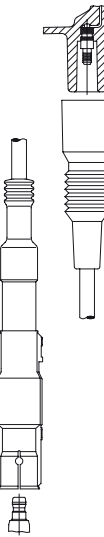

118/ 35  
 118/ 45  
 118/ 55  
 118/ 60  
 118/ 65  
 Verwendung für: /  
 applicable for:  
 AUDI

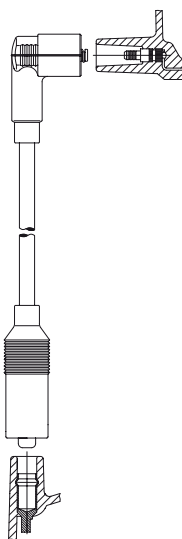

116/ 75  
 Verwendung für: /  
 applicable for:  
 BMW

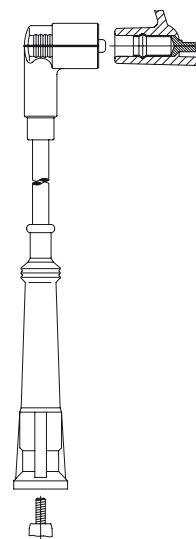

120/ 50  
 120/ 55  
 120/ 65  
 120/ 80  
 120/ 90  
 120/ 95  
 Verwendung für: /  
 applicable for:  
 BMW

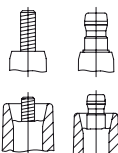

Connection spark plug: M4, SAE

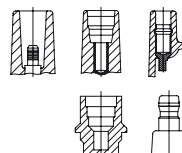

Connection distr. cap/ign. coil: 4 mm, Toyota 5 mm, DIN

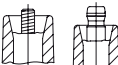

Connection distributor cap: M4, SAE



Connection distr. cap/ign. coil: Ford, SAE



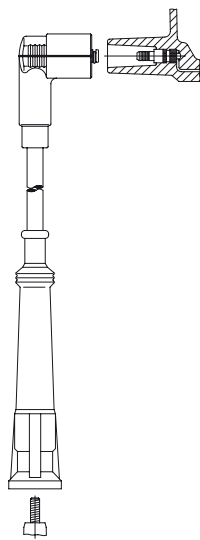

121/ 45  
 121/ 50  
 121/ 55  
 121/ 60  
 121/ 65  
 121/ 75  
 121/ 85  
 121/ 95  
 121/105  
 121/110  
 121/120  
 121/130  
 Verwendung für: /  
 applicable for:  
 BMW

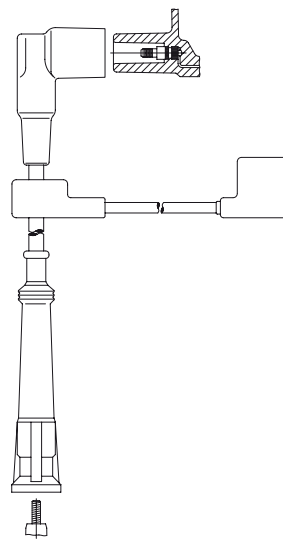

124/ 90  
 Verwendung für: /  
 applicable for:  
 BMW

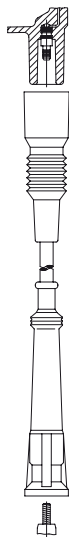

122/ 50  
 122/ 55  
 122/ 60  
 122/ 70  
 122/ 75  
 122/ 80  
 122/ 85  
 122/ 90  
 Verwendung für: /  
 applicable for:  
 BMW

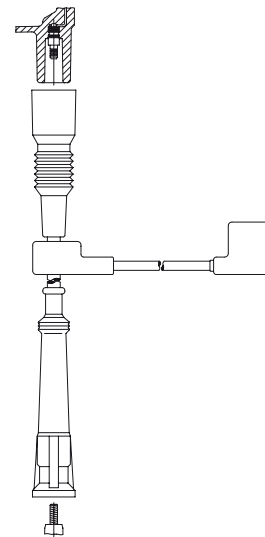

125/ 90  
 Verwendung für: /  
 applicable for:  
 BMW

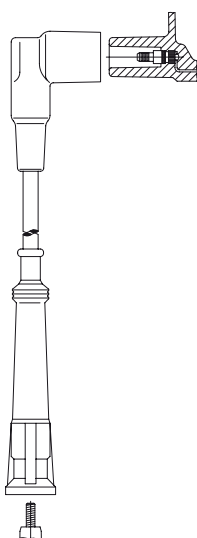

123/ 45  
 123/ 50  
 123/ 55  
 123/ 60  
 123/ 75  
 123/ 80  
 123/ 85  
 123/ 90  
 Verwendung für: /  
 applicable for:  
 BMW

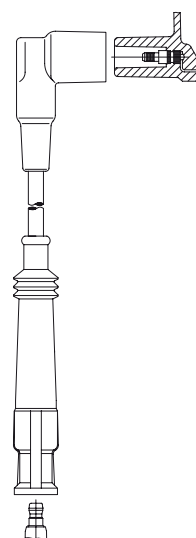

126/ 35  
 126/ 45  
 126/ 55  
 Verwendung für: /  
 applicable for:  
 BMW

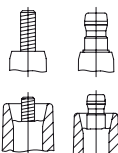

Connection spark plug: M4, SAE

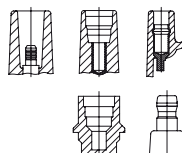

Connection distr. cap/ign. coil: 4 mm, Toyota 5 mm, DIN

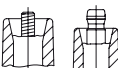

Connection distributor cap: M4, SAE



Connection distr. cap/ign. coil: Ford, SAE

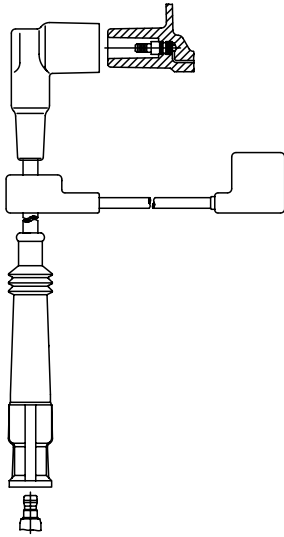

127/ 65  
Verwendung für: /  
applicable for:  
BMW

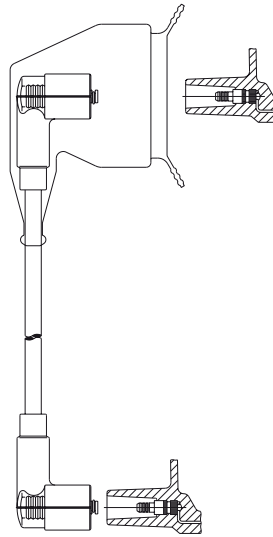

130/ 65  
130/ 75  
Verwendung für: /  
applicable for:  
BMW

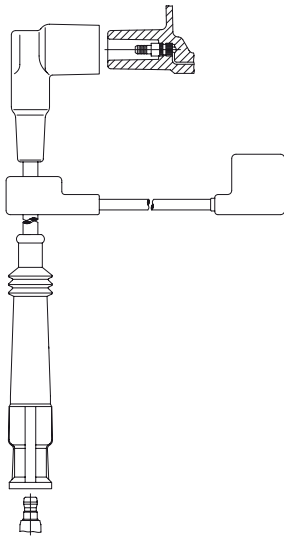

128/ 65  
Verwendung für: /  
applicable for:  
BMW

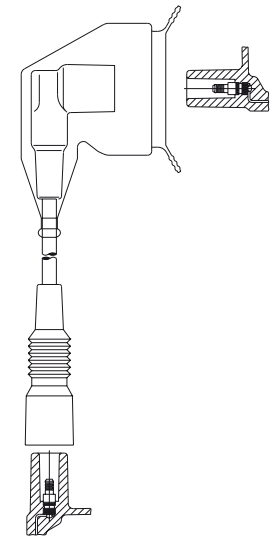

131/ 50  
131/ 60  
131/ 65  
131/ 75  
131/ 90  
Verwendung für: /  
applicable for:  
BMW

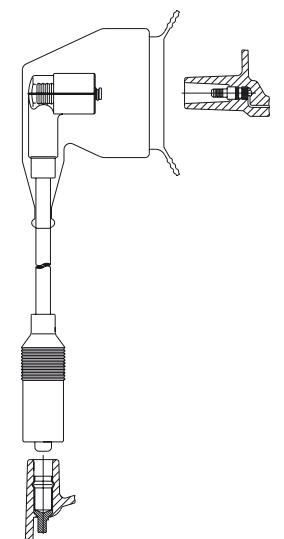

129/ 30  
Verwendung für: /  
applicable for:  
BMW

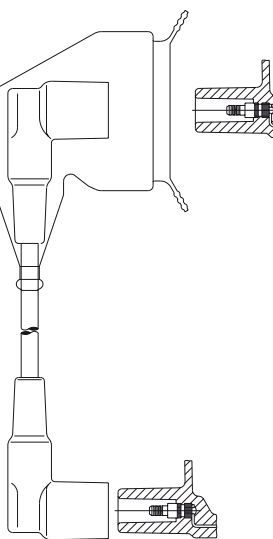

132/ 55  
132/ 75  
132/ 80  
Verwendung für: /  
applicable for:  
BMW

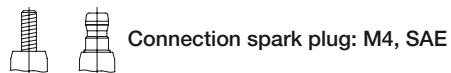

Connection spark plug: M4, SAE

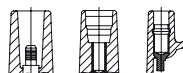

Connection distr. cap/ign. coil: 4 mm, Toyota 5 mm, DIN

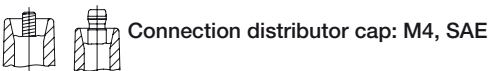

Connection distributor cap: M4, SAE



Connection distr. cap/ign. coil: Ford, SAE

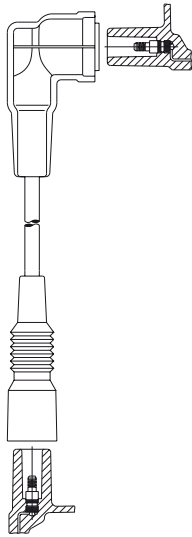

133/ 70  
133/ 90  
Verwendung für: /  
applicable for:  
BMW

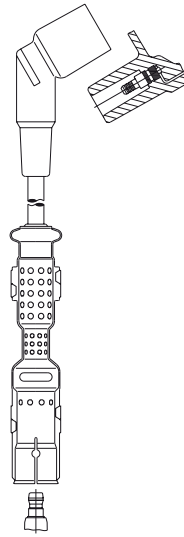

136/ 31  
136/ 33  
136/ 34  
136/ 35  
136/ 37  
136/ 40  
136/ 44  
Verwendung für: /  
applicable for:  
BMW

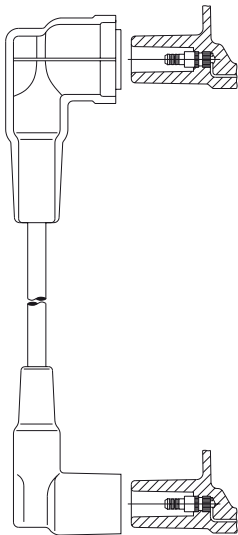

134/ 80  
Verwendung für: /  
applicable for:  
BMW

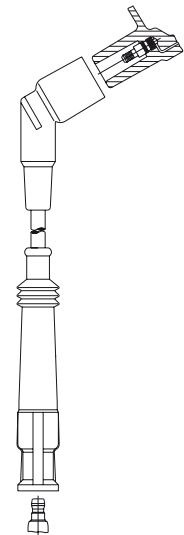

137/ 27  
137/ 30  
137/ 32  
137/ 37  
Verwendung für: /  
applicable for:  
BMW

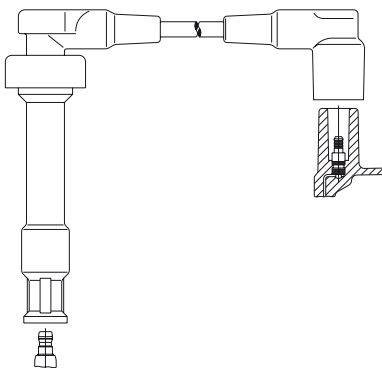

135/ 85  
135/ 95  
135/105  
135/110  
135/115  
Verwendung für: /  
applicable for:  
BMW

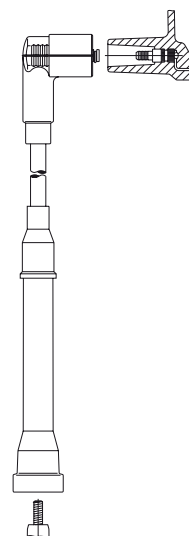

140/ 90  
140/105  
140/120  
140/135  
140/140  
Verwendung für: /  
applicable for:  
BMW

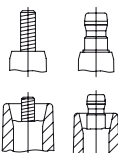

Connection spark plug: M4, SAE

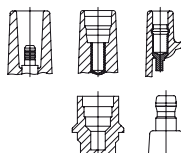

Connection distr. cap/ign. coil: 4 mm, Toyota 5 mm, DIN

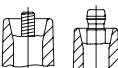

Connection distributor cap: M4, SAE



Connection distr. cap/ign. coil: Ford, SAE

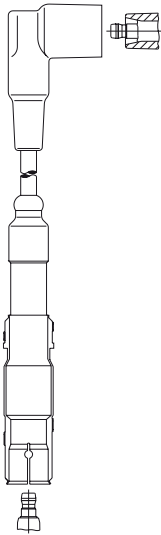

150/ 40  
 150/ 50  
 150/ 65  
 150/ 70  
 150/ 80  
 150/ 85  
 150/ 95  
 150/100  
 Verwendung für: /  
 applicable for:  
 MERCEDES-BENZ

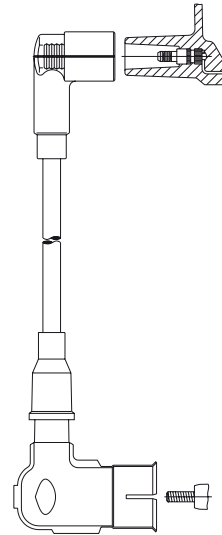

153/ 40  
 153/ 55  
 Verwendung für: /  
 applicable for:  
 MERCEDES-BENZ

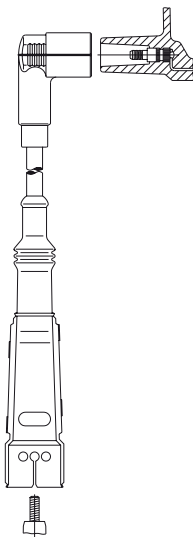

151/ 55  
 151/ 60  
 151/ 70  
 151/ 80  
 151/ 85  
 151/ 90  
 151/ 95  
 151/100  
 151/110  
 151/120  
 Verwendung für: /  
 applicable for:  
 MERCEDES-BENZ

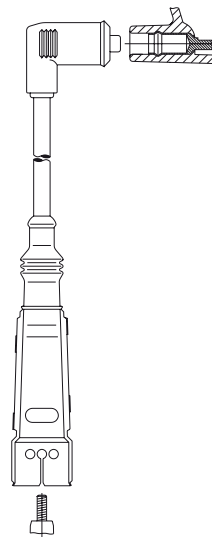

154/ 60  
 154/ 70  
 154/ 75  
 154/ 90  
 Verwendung für: /  
 applicable for:  
 AUDI  
 VW

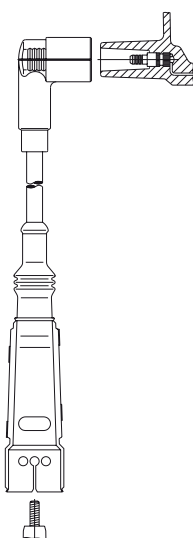

152/ 30  
 152/ 50  
 Verwendung für: /  
 applicable for:  
 MERCEDES-BENZ

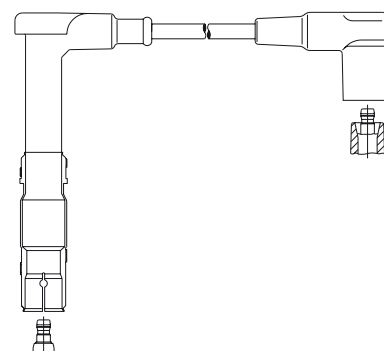

156/ 45  
 156/ 65  
 Verwendung für: /  
 applicable for:  
 MERCEDES-BENZ

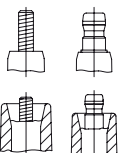

Connection spark plug: M4, SAE

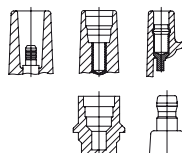

Connection distr. cap/ign. coil: 4 mm, Toyota 5 mm, DIN

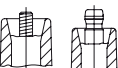

Connection distributor cap: M4, SAE



Connection distr. cap/ign. coil: Ford, SAE

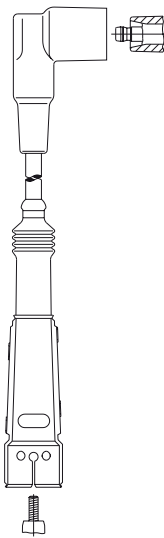

157/ 55  
 157/ 65  
 157/ 80  
 157/ 85  
 157/ 90  
 157/ 95  
 157/100  
 157/105  
 Verwendung für: /  
 applicable for:  
 MERCEDES-BENZ

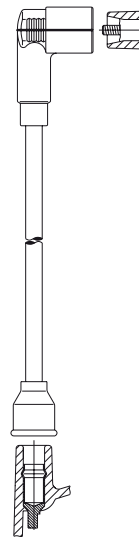

160/ 60  
 160/ 70  
 160/ 80  
 Verwendung für: /  
 applicable for:  
 MERCEDES-BENZ

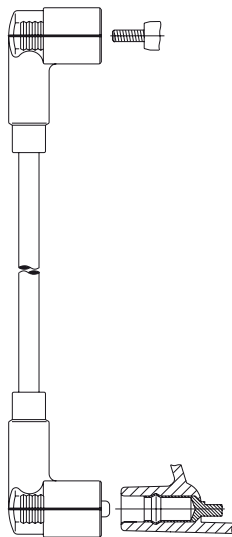

158/100  
 Verwendung für: /  
 applicable for:  
 MERCEDES-BENZ

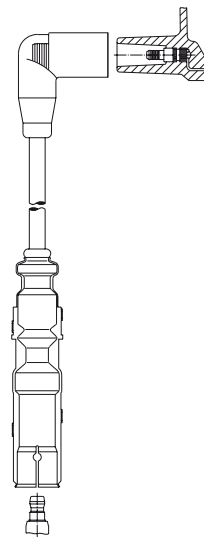

162/ 27  
 162/ 45  
 162/ 47  
 162/ 61  
 162/ 66  
 Verwendung für: /  
 applicable for:  
 AUDI  
 SEAT  
 SKODA  
 VW

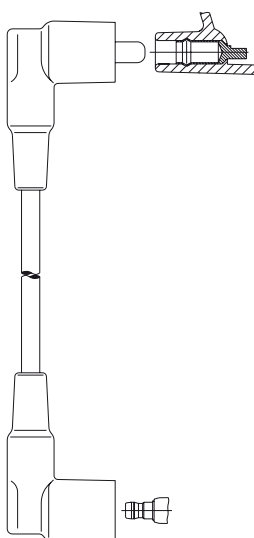

159/ 50  
 159/ 55  
 159/ 60  
 159/ 65  
 159/ 80  
 159/100  
 159/115  
 Verwendung für: /  
 applicable for:  
 MERCEDES-BENZ

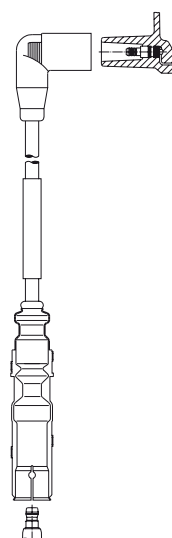

162E 27  
 162E 66  
 Verwendung für: /  
 applicable for:  
 SKODA  
 VW

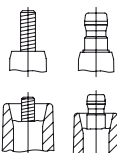

Connection spark plug: M4, SAE

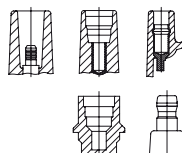

Connection distr. cap/ign. coil: 4 mm, Toyota 5 mm, DIN



Connection distributor cap: M4, SAE



Connection distr. cap/ign. coil: Ford, SAE

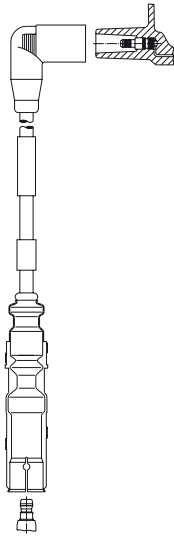

162F 65  
Verwendung für: /  
applicable for:  
SKODA  
VW

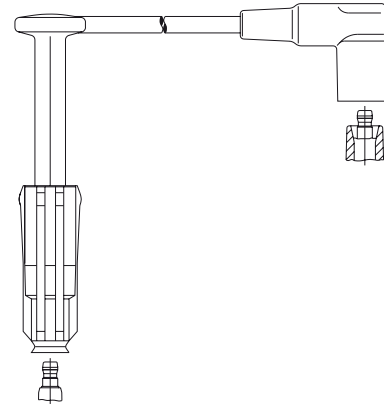

165/ 36  
165/ 46  
165/ 55  
165/ 61  
165/ 72  
165/ 75  
165/ 79  
165/ 85  
165/ 87  
165/ 90  
165/ 96  
165/ 99  
165/102  
165/103  
Verwendung für: /  
applicable for:  
MERCEDES-BENZ

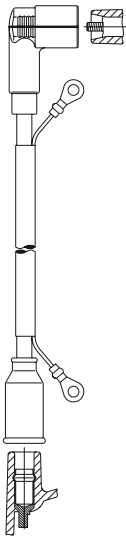

163/ 80  
Verwendung für: /  
applicable for:  
MERCEDES-BENZ

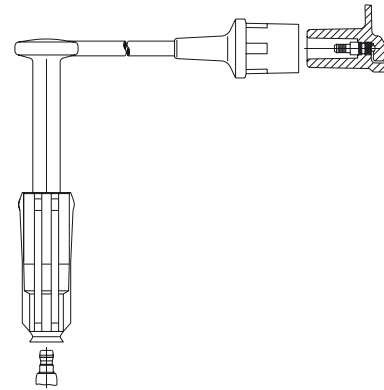

166/ 22  
166/ 33  
166/ 35  
166/ 41  
166/ 47  
166/ 53  
Verwendung für: /  
applicable for:  
DAEWOO  
MERCEDES-BENZ  
VW

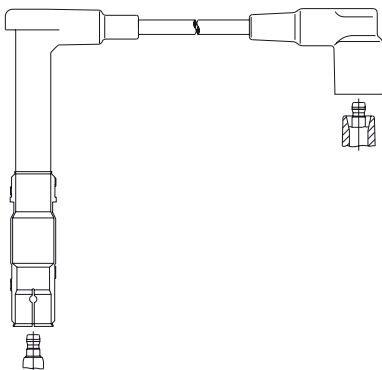

164/ 35  
164/ 45  
164/ 55  
164/ 60  
164/ 70  
164/ 75  
164/ 80  
164/ 85  
164/ 90  
164/ 95  
164/100  
164/105  
Verwendung für: /  
applicable for:  
MERCEDES-BENZ

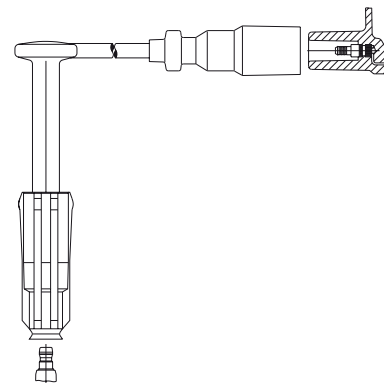

167/ 37  
167/ 45  
167/ 49  
167/ 50  
Verwendung für: /  
applicable for:  
MERCEDES-BENZ

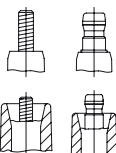

Connection spark plug: M4, SAE

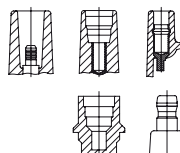

Connection distr. cap/ign. coil: 4 mm, Toyota 5 mm, DIN

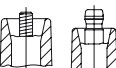

Connection distributor cap: M4, SAE



Connection distr. cap/ign. coil: Ford, SAE

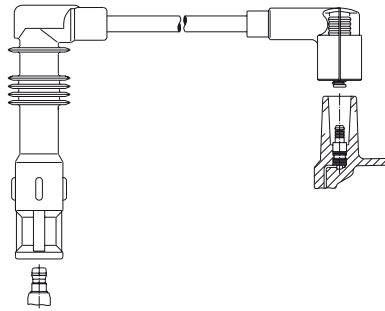

169/ 33  
169/ 37  
169/ 45  
169/ 53  
Verwendung für: /  
applicable for:  
SEAT  
VW

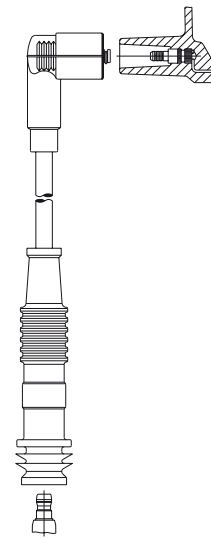

172/ 33  
172/ 47  
172/ 55  
172/ 58  
Verwendung für: /  
applicable for:  
FIAT  
LANCIA

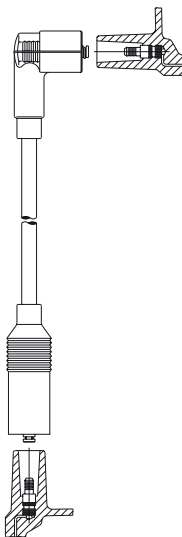

170/ 30  
Verwendung für: /  
applicable for:  
AUDI  
VW

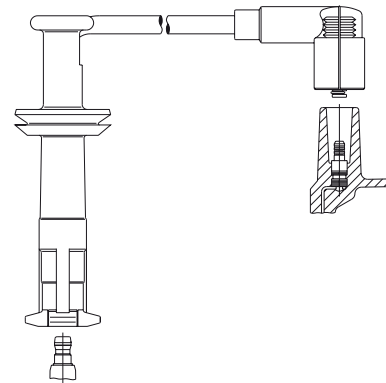

173/ 30  
173/ 36  
173/ 51  
173/ 62  
Verwendung für: /  
applicable for:  
FIAT  
LANCIA

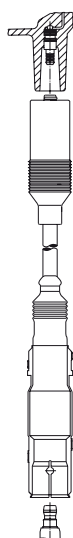

171/ 30  
171/ 40  
171/ 50  
171/ 60  
171/ 70  
Verwendung für: /  
applicable for:  
AUDI  
SEAT  
VW

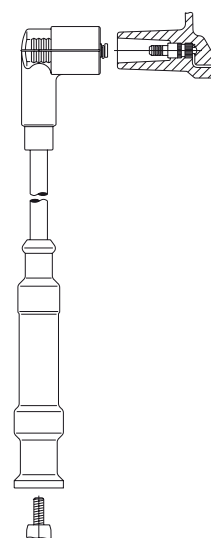

174/ 35  
174/ 45  
174/ 50  
174/ 55  
174/ 60  
174/ 65  
174/ 69  
174/ 70  
174/ 75  
174/ 81  
174/ 85  
Verwendung für: /  
applicable for:  
ALFA ROMEO

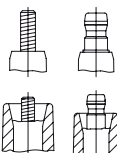

Connection spark plug: M4, SAE

Connection distributor cap: M4, SAE

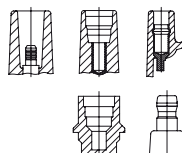

Connection distr. cap/ign. coil: 4 mm, Toyota 5 mm, DIN

Connection distr. cap/ign. coil: Ford, SAE

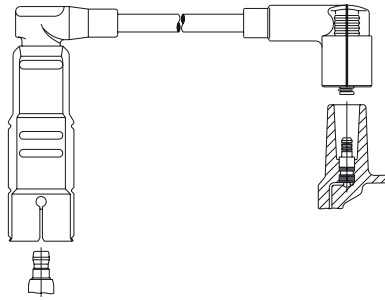

175/ 50  
175/ 55  
175/ 60  
175/ 67  
175/ 70  
Verwendung für: /  
applicable for:  
ALFA ROMEO

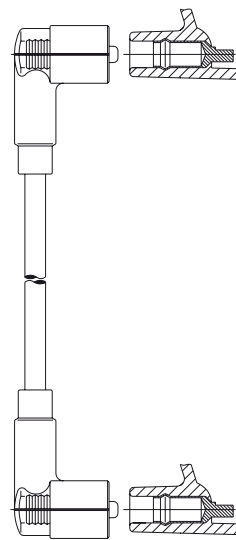

177/ 24  
177/ 25  
177/ 28  
Verwendung für: /  
applicable for:  
FIAT  
LANCIA

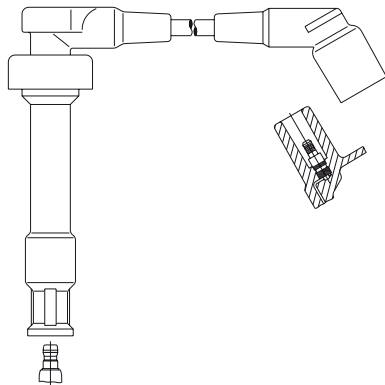

176/ 75  
176/ 90  
176/ 95  
176/105  
Verwendung für: /  
applicable for:  
BMW

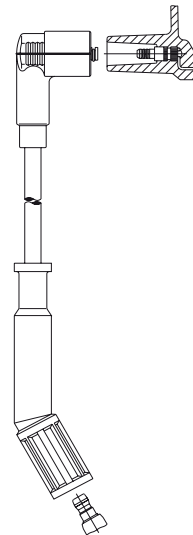

178/ 32  
178/ 42  
178/ 60  
178/ 65  
Verwendung für: /  
applicable for:  
FIAT  
LANCIA

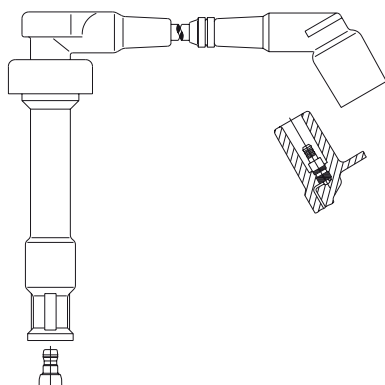

176S 75  
176S 88  
176S 91  
176S102  
Verwendung für: /  
applicable for:  
BMW

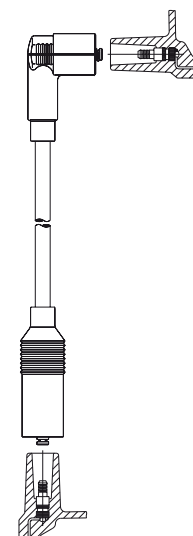

179/ 57  
Verwendung für: /  
applicable for:  
VW

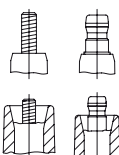

Connection spark plug: M4, SAE

Connection distributor cap: M4, SAE

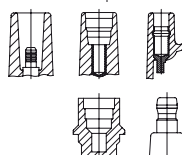

Connection distr. cap/ign. coil: 4 mm, Toyota 5 mm, DIN

Connection distr. cap/ign. coil: Ford, SAE



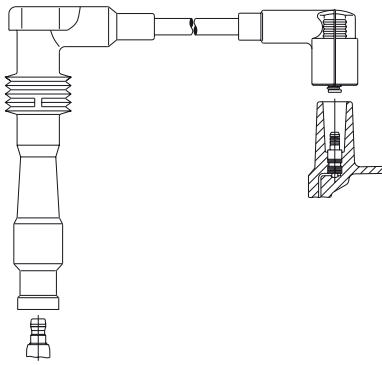

180/ 20  
 180/ 30  
 180/ 40  
 180/ 50  
 180/ 52  
 180/ 60  
 Verwendung für: /  
 applicable for:  
 OPEL

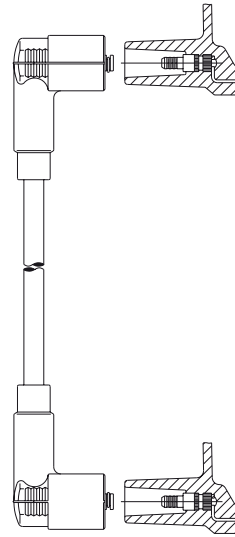

183/ 30  
 Verwendung für: /  
 applicable for:  
 OPEL

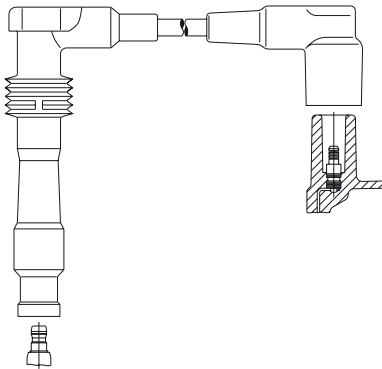

181/ 20  
 181/ 30  
 181/ 32  
 181/ 39  
 181/ 40  
 181/ 44  
 181/ 50  
 181/ 55  
 181/ 60  
 Verwendung für: /  
 applicable for:  
 HOLDEN  
 OPEL  
 VAUXHALL

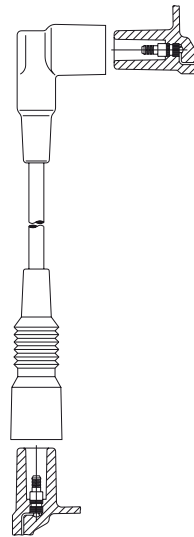

184/ 40  
 Verwendung für: /  
 applicable for:  
 HOLDEN  
 OPEL

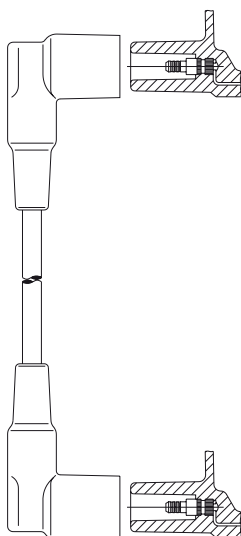

182/ 30  
 Verwendung für: /  
 applicable for:  
 OPEL  
 VAUXHALL

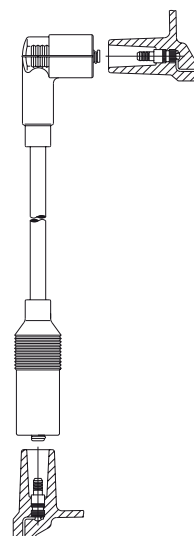

185/ 50  
 Verwendung für: /  
 applicable for:  
 OPEL

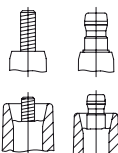

Connection spark plug: M4, SAE

Connection distributor cap: M4, SAE

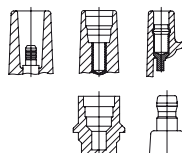

Connection distr. cap/ign. coil: 4 mm, Toyota 5 mm, DIN

Connection distr. cap/ign. coil: Ford, SAE

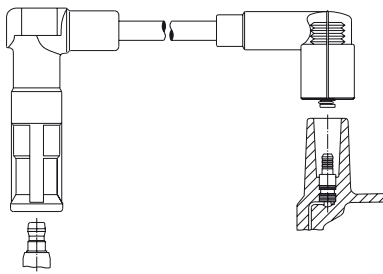

186/ 23  
 186/ 27  
 186/ 30  
 186/ 43  
 186/ 45  
 186/ 55  
 186/ 65  
 Verwendung für: /  
 applicable for:  
 CITROEN  
 FIAT  
 LANCIA  
 PEUGEOT

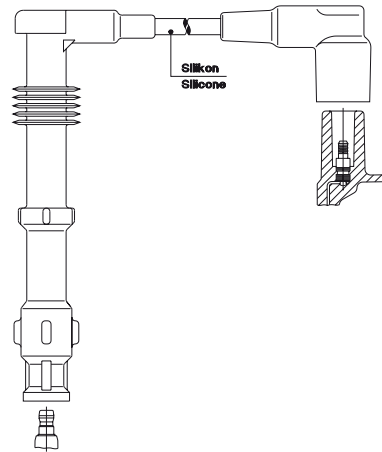

189A 80  
 189A 85  
 Verwendung für: /  
 applicable for:  
 AUDI

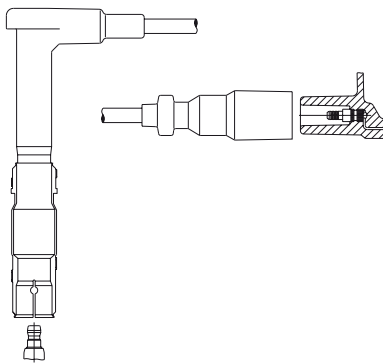

187/ 45  
 187/ 50  
 Verwendung für: /  
 applicable for:  
 MERCEDES-BENZ

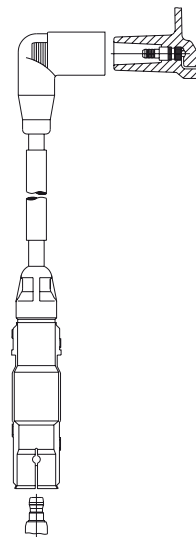

190E 57  
 190E 66  
 190E 71  
 190E 72  
 190E 86  
 Verwendung für: /  
 applicable for:  
 VW

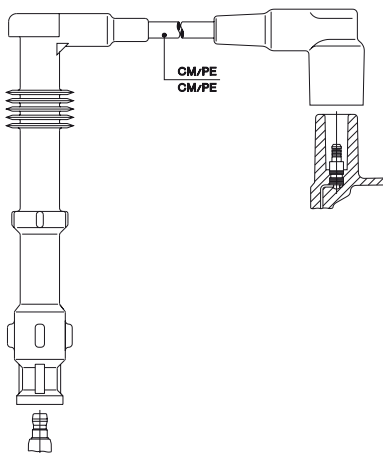

189/ 84  
 Verwendung für: /  
 applicable for:  
 AUDI

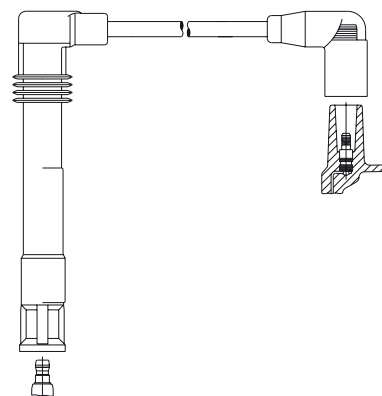

191/ 54  
 191/ 59  
 191/ 66  
 191/ 75  
 Verwendung für: /  
 applicable for:  
 AUDI  
 SKODA



Connection spark plug: M4, SAE

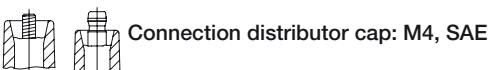

Connection distributor cap: M4, SAE

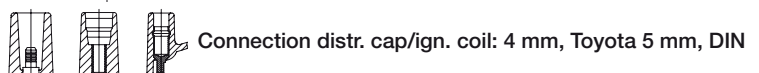

Connection distr. cap/ign. coil: 4 mm, Toyota 5 mm, DIN

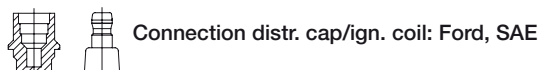

Connection distr. cap/ign. coil: Ford, SAE

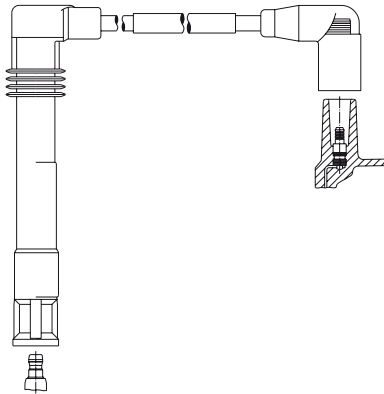

191E 47  
191E 50  
191E 53  
191E 61  
Verwendung für: /  
applicable for:  
VW

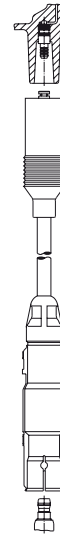

195/ 30  
195/ 40  
195/ 55  
195/ 65  
Verwendung für: /  
applicable for:  
SEAT  
VW

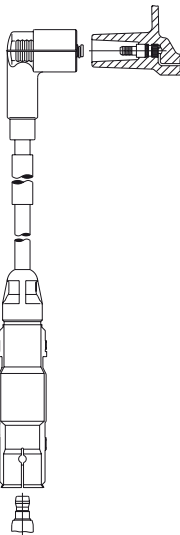

192/ 54  
192/ 68  
192/ 69  
192/ 85  
192/ 86  
192/ 98  
Verwendung für: /  
applicable for:  
FORD  
VW

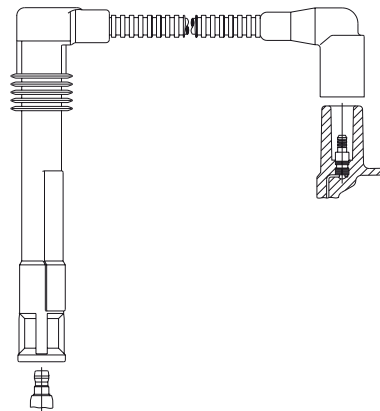

196/ 42  
196/ 44  
196/ 47  
196/ 48  
Verwendung für: /  
applicable for:  
AUDI  
SKODA  
VW

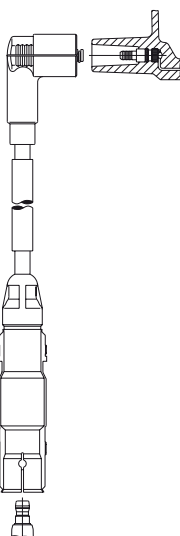

193/ 52  
193/ 69  
193/ 86  
193/ 92  
193/ 99  
193/100  
Verwendung für: /  
applicable for:  
VW



197E 25  
197E 27  
197E 29  
197E 32  
Verwendung für: /  
applicable for:  
CHRYSLER  
MERCEDES-BENZ  
MERCEDES-BENZ  
(FJDA)

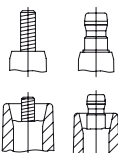

Connection spark plug: M4, SAE

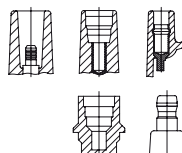

Connection distr. cap/ign. coil: 4 mm, Toyota 5 mm, DIN

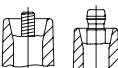

Connection distributor cap: M4, SAE



Connection distr. cap/ign. coil: Ford, SAE

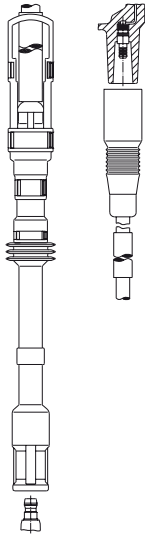

198/ 74  
198/ 75  
198/ 76  
198/ 82  
Verwendung für: /  
applicable for:  
AUDI  
SEAT  
SKODA  
VW

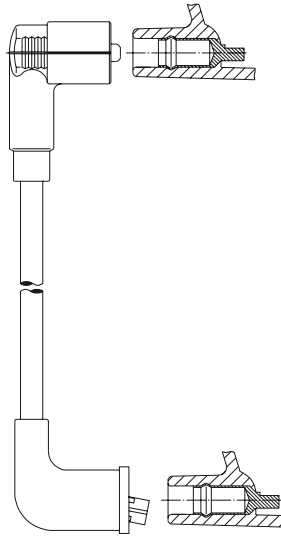

202/ 52  
Verwendung für: /  
applicable for:  
ALFA ROMEO

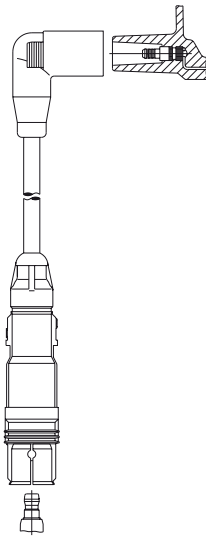

199R 59  
199R 66  
199R 77  
199R 80  
Verwendung für: /  
applicable for:  
VW

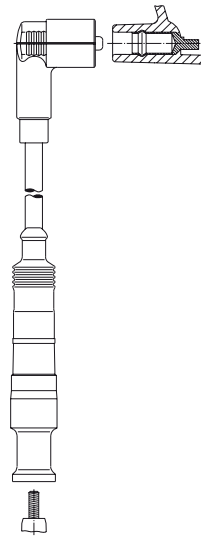

204/ 75  
204/ 76  
204/ 77  
Verwendung für: /  
applicable for:  
ALFA ROMEO

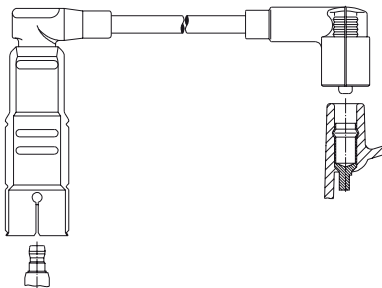

201/ 43  
201/ 55  
201/ 68  
Verwendung für: /  
applicable for:  
ALFA ROMEO

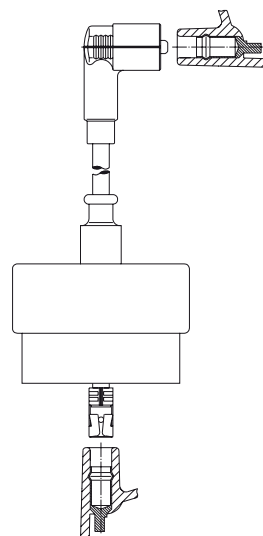

208/ 53  
Verwendung für: /  
applicable for:  
ALFA ROMEO

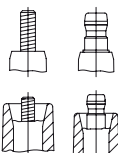

Connection spark plug: M4, SAE

Connection distributor cap: M4, SAE

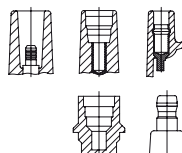

Connection distr. cap/ign. coil: 4 mm, Toyota 5 mm, DIN

Connection distr. cap/ign. coil: Ford, SAE

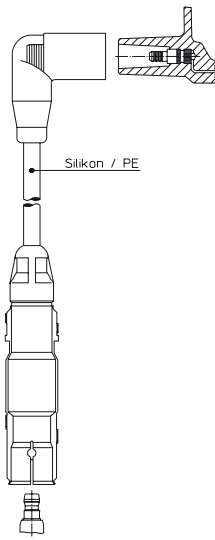

210/ 26  
210/ 63  
Verwendung für: /  
applicable for:  
AUDI  
SEAT  
SKODA  
VW

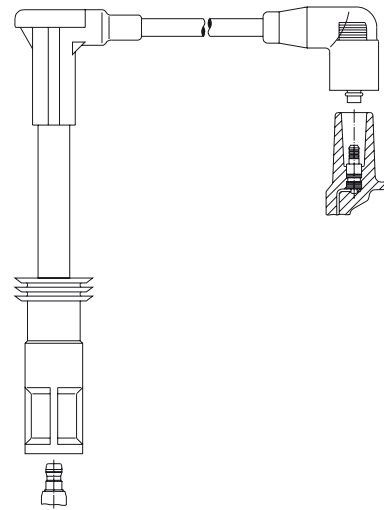

212/ 14  
212/ 33  
Verwendung für: /  
applicable for:  
ALFA ROMEO

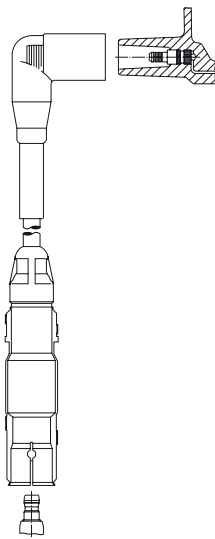

210E 47  
210E 59  
Verwendung für: /  
applicable for:  
AUDI  
SEAT  
SKODA  
VW

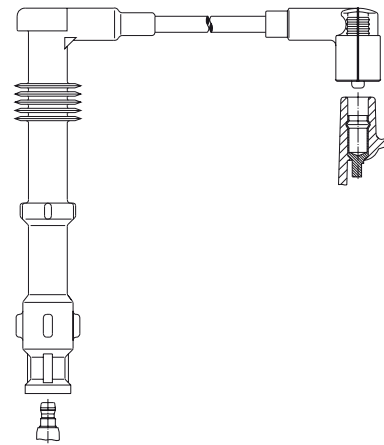

216/ 65  
Verwendung für: /  
applicable for:  
FORD

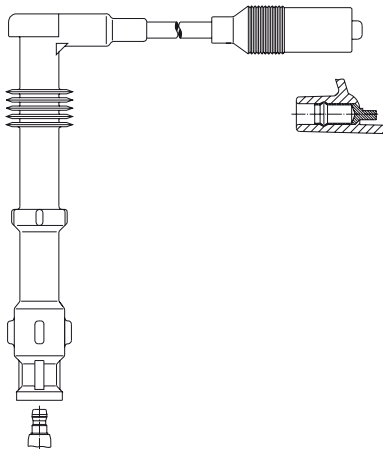

211/ 60  
Verwendung für: /  
applicable for:  
FORD

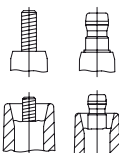

Connection spark plug: M4, SAE

Connection distributor cap: M4, SAE

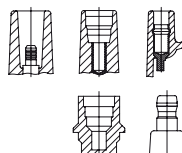

Connection distr. cap/ign. coil: 4 mm, Toyota 5 mm, DIN

Connection distr. cap/ign. coil: Ford, SAE

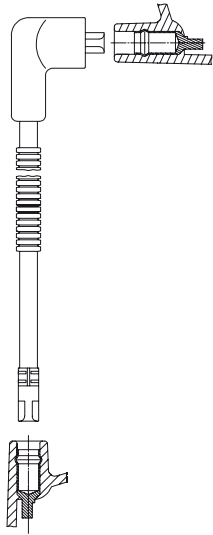

3A10E 52  
Verwendung für: /  
applicable for:  
ROVER

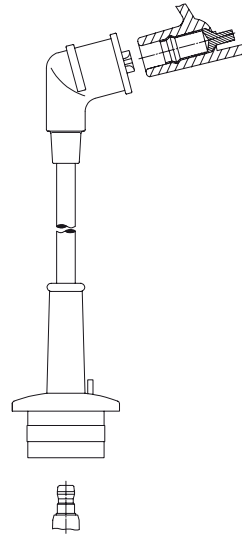

3A14/ 45  
Verwendung für: /  
applicable for:  
TOYOTA

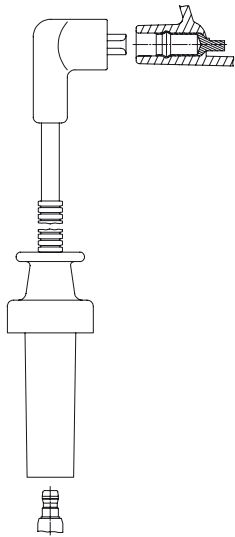

3A11E 34  
3A11E 46  
3A11E 50  
3A11E 61  
Verwendung für: /  
applicable for:  
ROVER

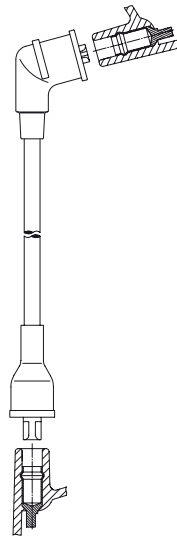

3A15/ 37  
Verwendung für: /  
applicable for:  
DAIHATSU  
TOYOTA

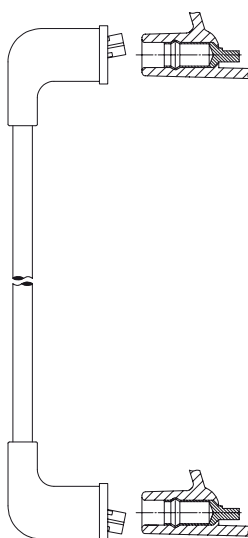

3A12/ 53  
Verwendung für: /  
applicable for:  
SUZUKI  
TOYOTA

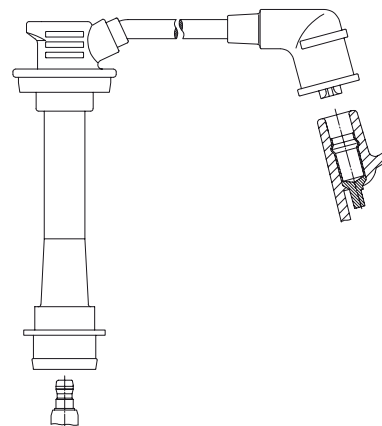

3A16/ 25  
3A16/ 32  
3A16/ 35  
3A16/ 44  
Verwendung für: /  
applicable for:  
TOYOTA

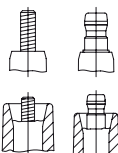

Connection spark plug: M4, SAE

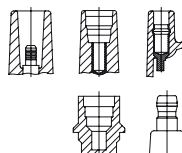

Connection distr. cap/ign. coil: 4 mm, Toyota 5 mm, DIN

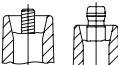

Connection distributor cap: M4, SAE



Connection distr. cap/ign. coil: Ford, SAE

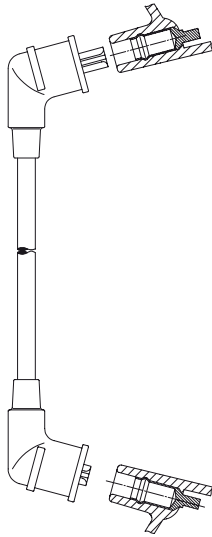

3A18/ 64  
Verwendung für: /  
applicable for:  
OPEL  
TOYOTA  
VAUXHALL

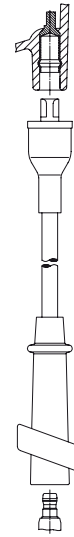

3A22/ 46  
3A22/ 65  
3A22/ 67  
Verwendung für: /  
applicable for:  
SUZUKI

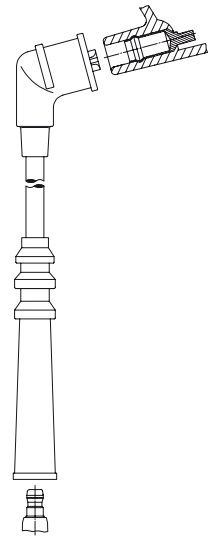

3A19/ 40  
Verwendung für: /  
applicable for:  
NISSAN  
TOYOTA

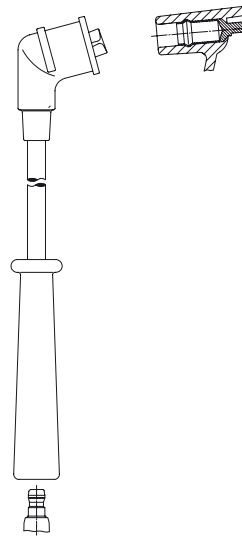

3A23/ 30  
3A23/ 36  
3A23/ 42  
3A23/ 48  
3A23/ 51  
3A23/ 53  
3A23/ 56  
3A23/ 60  
3A23/ 62  
3A23/ 65  
3A23/ 67  
3A23/ 70  
3A23/ 73  
3A23/ 78  
3A23/ 80  
3A23/ 83  
3A23/ 87  
3A23/ 90  
Verwendung für: /  
applicable for:  
DAIHATSU  
HYUNDAI  
MAZDA  
MITSUBISHI

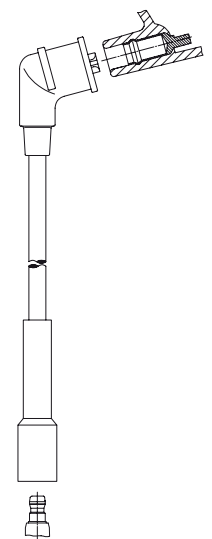

3A20/ 20  
3A20/ 21  
3A20/ 22  
3A20/ 23  
3A20/ 34  
3A20/ 35  
3A20/ 39  
3A20/ 40  
Verwendung für: /  
applicable for:  
TOYOTA

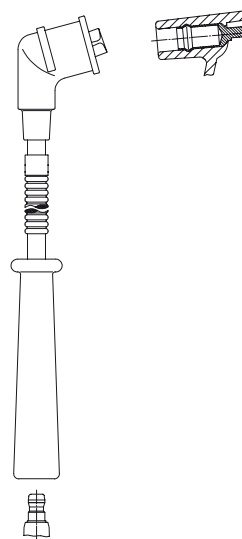

3A23E 67  
3A23E 74  
3A23E 94  
Verwendung für: /  
applicable for:  
MAZDA

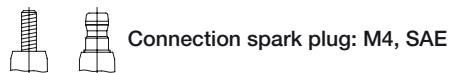

Connection spark plug: M4, SAE

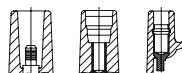

Connection distr. cap/ign. coil: 4 mm, Toyota 5 mm, DIN

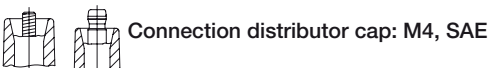

Connection distributor cap: M4, SAE



Connection distr. cap/ign. coil: Ford, SAE

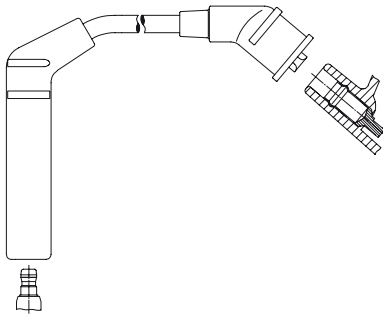

3A24/ 42  
 3A24/ 46  
 3A24/ 48  
 3A24/ 52  
 3A24/ 57  
 3A24/ 66  
 Verwendung für: /  
 applicable for:  
 MITSUBISHI

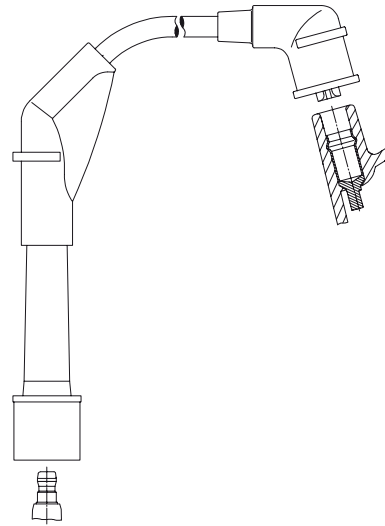

3A28/ 46  
 3A28/ 50  
 3A28/ 59  
 3A28/ 66  
 Verwendung für: /  
 applicable for:  
 NISSAN

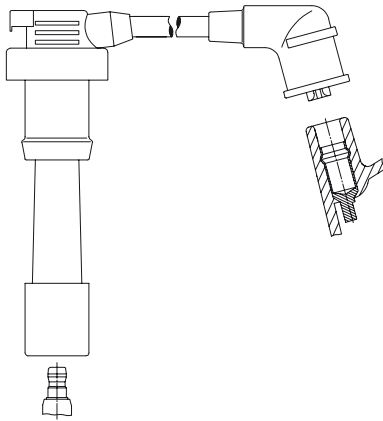

3A25/ 27  
 3A25/ 40  
 3A25/ 60  
 3A25/ 65  
 3A25/ 74  
 3A25/ 77  
 Verwendung für: /  
 applicable for:  
 MITSUBISHI

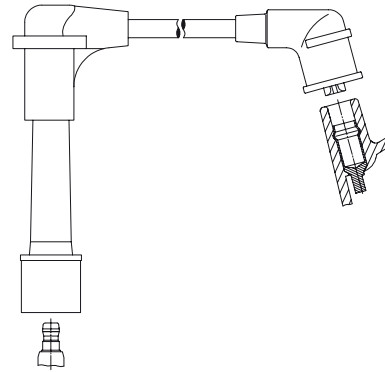

3A29/ 31  
 3A29/ 45  
 Verwendung für: /  
 applicable for:  
 NISSAN

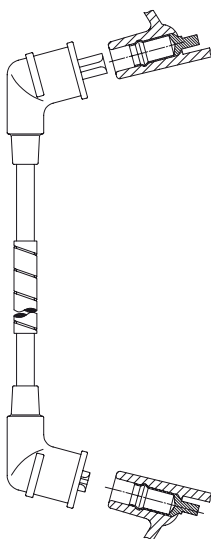

3A27E 40  
 Verwendung für: /  
 applicable for:  
 TOYOTA

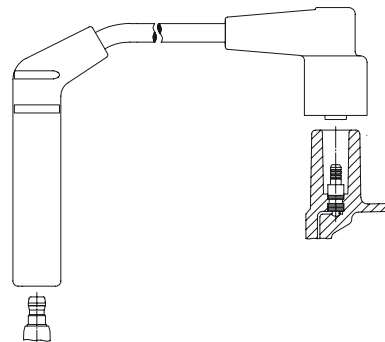

3A30/ 14  
 3A30/ 27  
 Verwendung für: /  
 applicable for:  
 CHEVROLET  
 DAEWOO

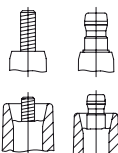

Connection spark plug: M4, SAE

Connection distributor cap: M4, SAE

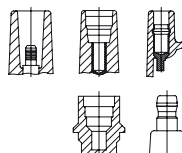

Connection distr. cap/ign. coil: 4 mm, Toyota 5 mm, DIN

Connection distr. cap/ign. coil: Ford, SAE



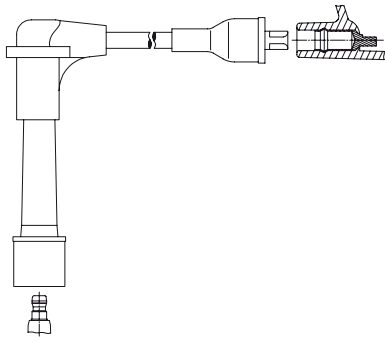

3A31/ 13  
 3A31/ 25  
 3A31/ 35  
 Verwendung für: /  
 applicable for:  
 NISSAN

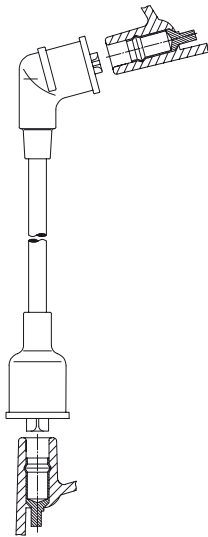

3A32/ 16  
 3A32/ 25  
 3A32/ 22  
 3A32/ 33  
 Verwendung für: /  
 applicable for:  
 HOLDEN  
 MITSUBISHI  
 NISSAN

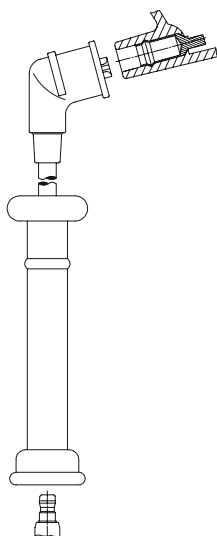

3A33/ 39  
 3A33/ 52  
 3A33/ 60  
 3A33/ 74  
 Verwendung für: /  
 applicable for:  
 HOLDEN  
 NISSAN



3A34/ 52  
 3A34/ 56  
 3A34/ 58  
 3A34/ 62  
 3A34/ 64  
 3A34/ 66  
 3A34/ 71  
 3A34/ 75  
 Verwendung für: /  
 applicable for:  
 FORD  
 OPEL  
 SUZUKI  
 VAUXHALL

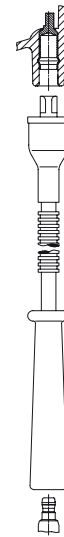

3A34E 34  
 3A34E 39  
 Verwendung für: /  
 applicable for:  
 MAZDA

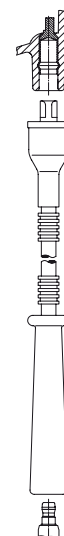

3A34F 51  
 Verwendung für: /  
 applicable for:  
 MAZDA

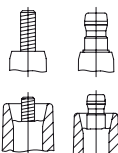

Connection spark plug: M4, SAE

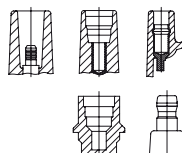

Connection distr. cap/ign. coil: 4 mm, Toyota 5 mm, DIN

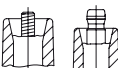

Connection distributor cap: M4, SAE



Connection distr. cap/ign. coil: Ford, SAE

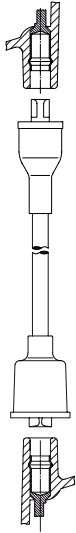

3A35/48  
Verwendung für: /  
applicable for:  
FORD

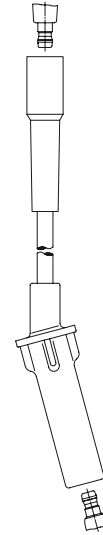

3A38/ 38  
3A38/ 45  
3A38/ 53  
3A38/ 61  
Verwendung für: /  
applicable for:  
CHRYSLER  
VW

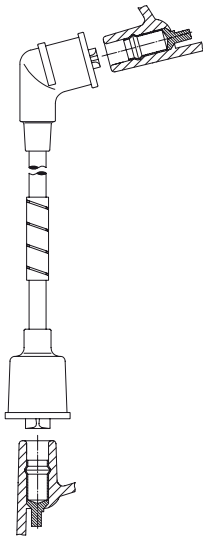

3A36E 49  
Verwendung für: /  
applicable for:  
DAIHATSU

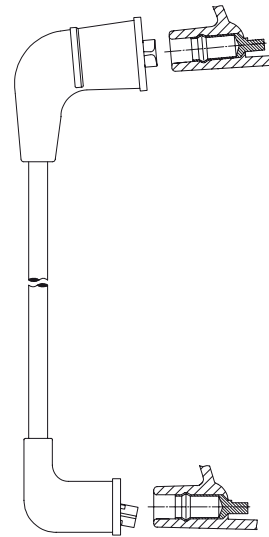

3A39/ 46  
Verwendung für: /  
applicable for:  
DAEWOO  
DAIHATSU

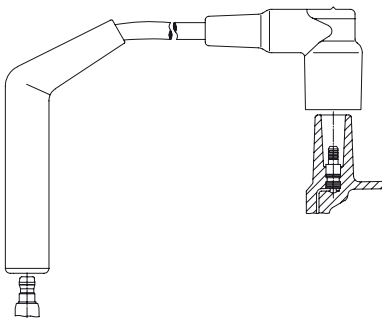

3A37/ 22  
3A37/ 33  
3A37/ 44  
3A37/ 46  
Verwendung für: /  
applicable for:  
FORD

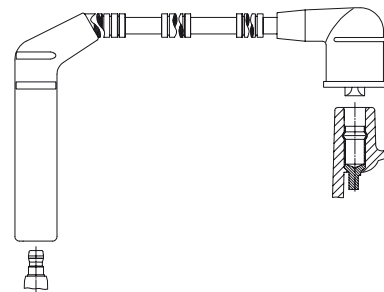

3A40H 78  
3A40H 83  
3A40H100  
3A40H110  
Verwendung für: /  
applicable for:  
MAZDA

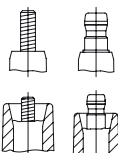

Connection spark plug: M4, SAE

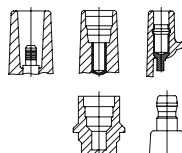

Connection distr. cap/ign. coil: 4 mm, Toyota 5 mm, DIN

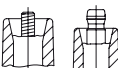

Connection distributor cap: M4, SAE



Connection distr. cap/ign. coil: Ford, SAE

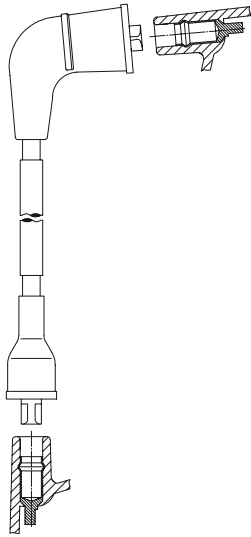

3A41E 37  
Verwendung für: /  
applicable for:  
MAZDA

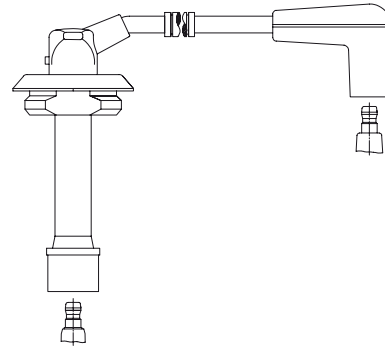

3A44E 43  
3A44E 77  
Verwendung für: /  
applicable for:  
SUBARU

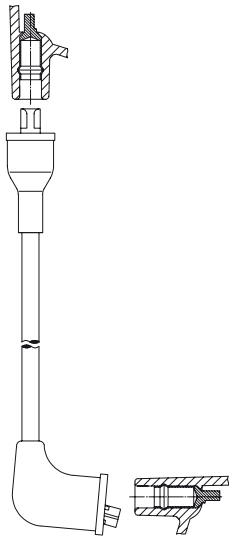

3A42/ 77  
Verwendung für: /  
applicable for:  
SUZUKI

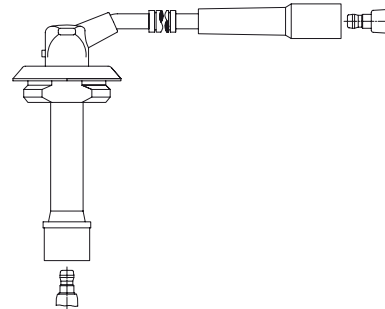

3A45E 80  
Verwendung für: /  
applicable for:  
SUBARU

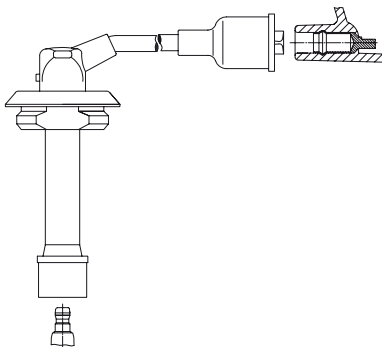

3A43/ 57  
3A43/ 60  
3A43/ 62  
3A43/ 63  
3A43/ 64  
3A43/ 74  
Verwendung für: /  
applicable for:  
SUBARU

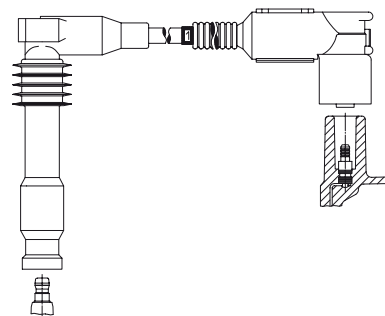

3A46E 57  
Verwendung für: /  
applicable for:  
OPEL  
VAUXHALL

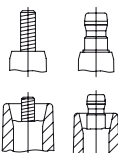

Connection spark plug: M4, SAE

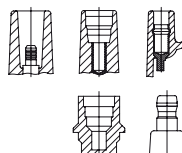

Connection distr. cap/ign. coil: 4 mm, Toyota 5 mm, DIN

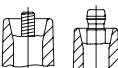

Connection distributor cap: M4, SAE



Connection distr. cap/ign. coil: Ford, SAE

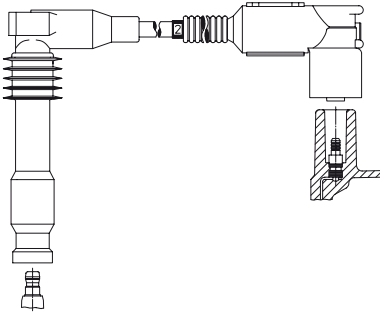

3A47E 57  
Verwendung für: /  
applicable for:  
OPEL  
VAUXHALL

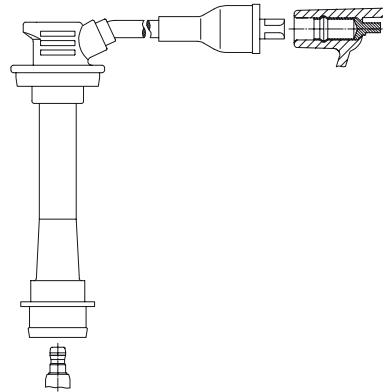

3A50/ 40  
Verwendung für: /  
applicable for:  
TOYOTA

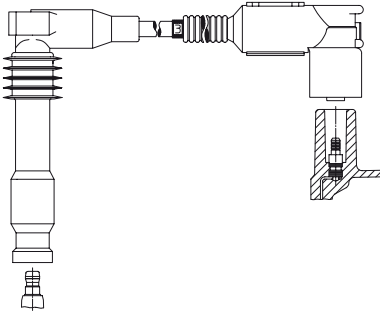

3A48E 45  
Verwendung für: /  
applicable for:  
OPEL  
VAUXHALL

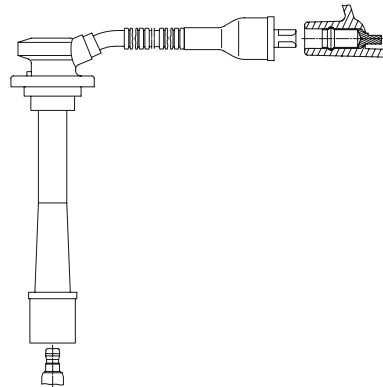

3A51F 38  
Verwendung für: /  
applicable for:  
KIA

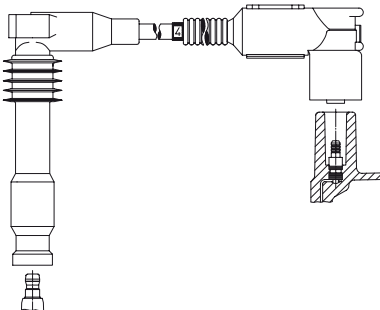

3A49E 31  
Verwendung für: /  
applicable for:  
OPEL  
VAUXHALL

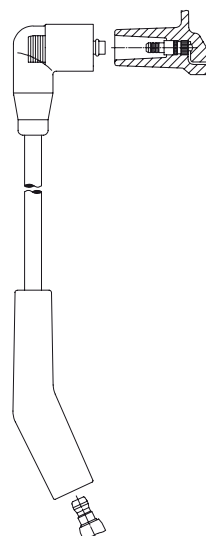

3A52/ 41  
3A52/ 43  
3A52/ 57  
3A52/ 60  
3A52/ 66  
3A52/ 67  
3A52/ 73  
3A52/ 75  
Verwendung für: /  
applicable for:  
LAND ROVER

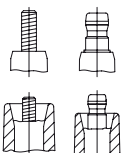

Connection spark plug: M4, SAE

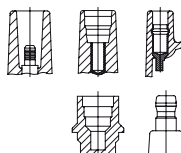

Connection distr. cap/ign. coil: 4 mm, Toyota 5 mm, DIN

Connection distributor cap: M4, SAE

Connection distr. cap/ign. coil: Ford, SAE

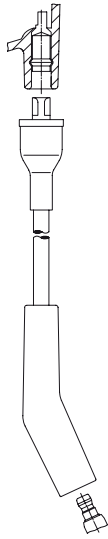

3A53/ 60  
3A53/ 73  
Verwendung für: /  
applicable for:  
LAND ROVER

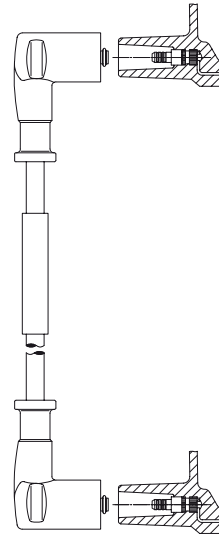

3A55E 29  
Verwendung für: /  
applicable for:  
SKODA

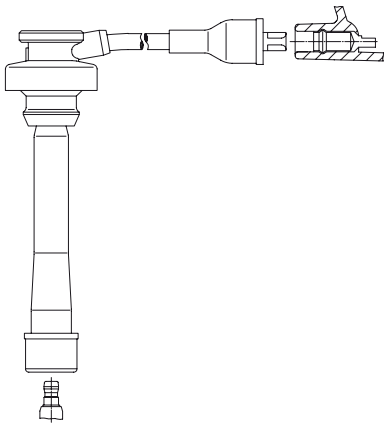

3A54/ 50  
Verwendung für: /  
applicable for:  
MITSUBISHI

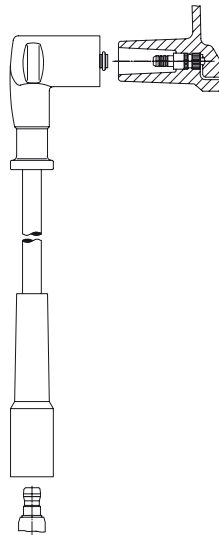

3A56/ 26  
3A56/ 29  
3A56/ 36  
3A56/ 40  
3A56/ 50  
Verwendung für: /  
applicable for:  
SKODA

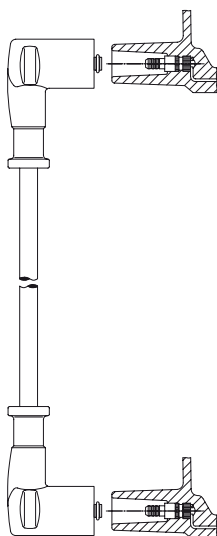

3A55/ 30  
Verwendung für: /  
applicable for:  
SKODA

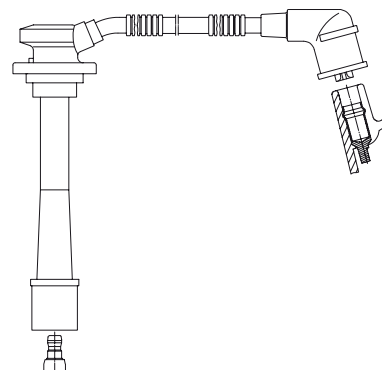

3A57F 50  
3A57F 62  
Verwendung für: /  
applicable for:  
KIA

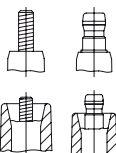

Connection spark plug: M4, SAE

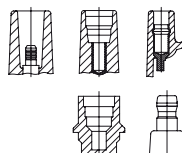

Connection distr. cap/ign. coil: 4 mm, Toyota 5 mm, DIN

Connection distributor cap: M4, SAE

Connection distr. cap/ign. coil: Ford, SAE

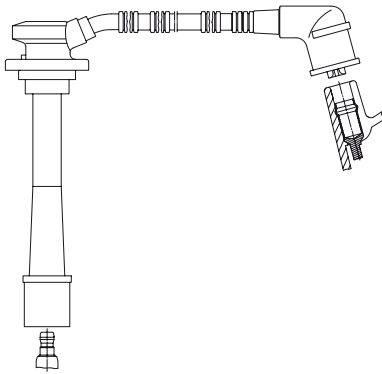

3A57J 71  
3A57J 78  
3A57J 93  
Verwendung für: /  
applicable for:  
KIA

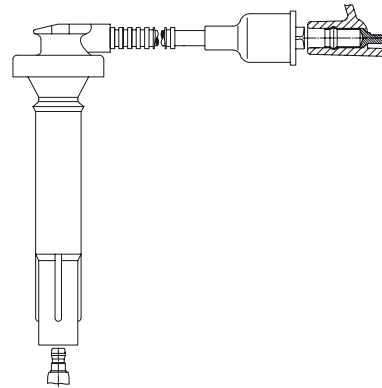

3A60E 46  
3A60E 50  
3A60E 60  
Verwendung für: /  
applicable for:  
SUBARU

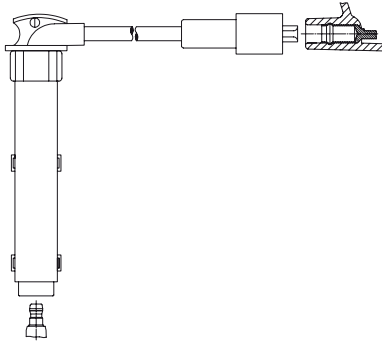

3A58/ 29  
Verwendung für: /  
applicable for:  
ROVER

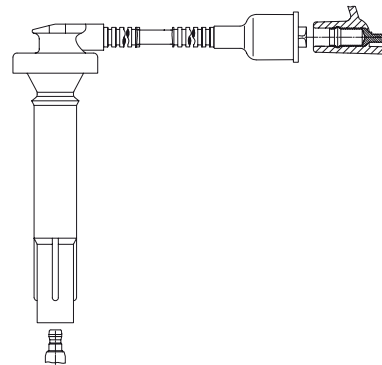

3A60F 64  
Verwendung für: /  
applicable for:  
SUBARU

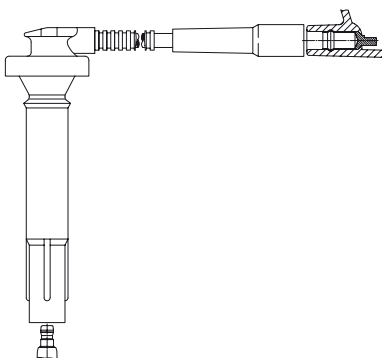

3A59E 42  
3A59E 45  
3A59E 55  
3A59E 57  
Verwendung für: /  
applicable for:  
SUBARU

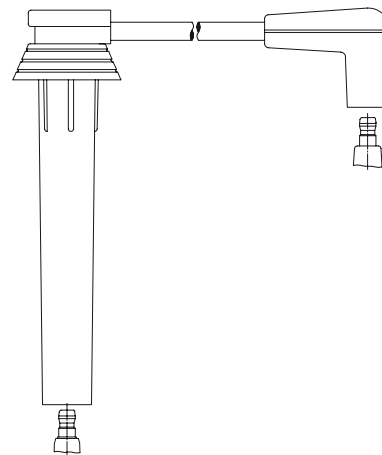

3A61/ 12  
3A61/ 14  
3A61/ 18  
3A61/ 22  
3A61/ 24  
3A61/ 26  
Verwendung für: /  
applicable for:  
CHRYSLER  
DODGE  
JEEP  
MITSUBISHI

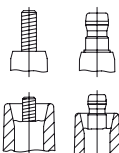

Connection spark plug: M4, SAE

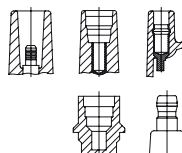

Connection distr. cap/ign. coil: 4 mm, Toyota 5 mm, DIN

Connection distributor cap: M4, SAE

Connection distr. cap/ign. coil: Ford, SAE

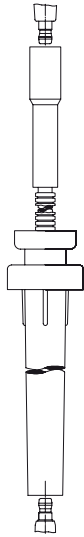

3A62E 31  
Verwendung für: /  
applicable for:  
CHRYSLER

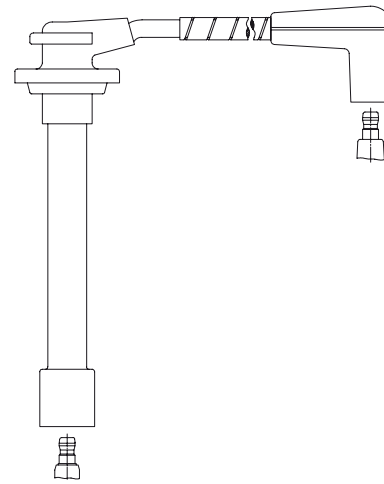

3A64E 50  
3A64E 51  
3A64E 56  
3A64E 58  
3A64E 63  
Verwendung für: /  
applicable for:  
ISUZU  
OPEL  
VAUXHALL

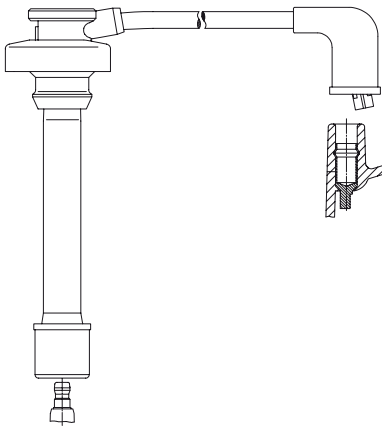

3A63/ 34  
3A63/ 38  
3A63/ 47  
3A63/ 49  
3A63/ 59  
3A63/ 60  
Verwendung für: /  
applicable for:  
CHRYSLER

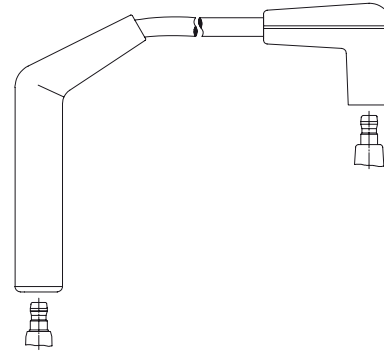

3A65/ 14  
Verwendung für: /  
applicable for:  
CHEVROLET  
DAEWOO

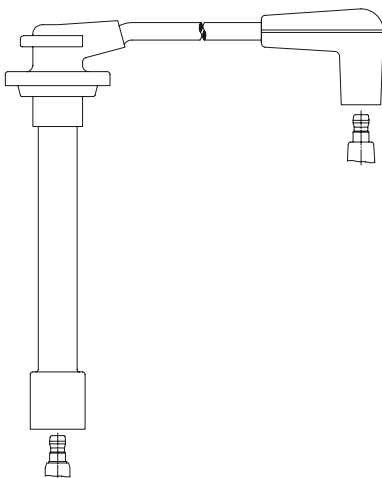

3A64/ 58  
Verwendung für: /  
applicable for:  
ISUZU  
OPEL  
VAUXHALL

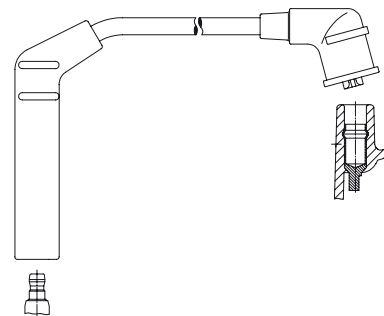

3A66/ 28  
3A66/ 36  
3A66/ 38  
3A66/ 44  
3A66/ 46  
Verwendung für: /  
applicable for:  
HYUNDAI

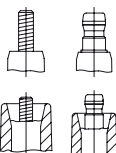

Connection spark plug: M4, SAE

Connection distributor cap: M4, SAE

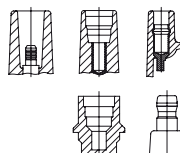

Connection distr. cap/ign. coil: 4 mm, Toyota 5 mm, DIN

Connection distr. cap/ign. coil: Ford, SAE

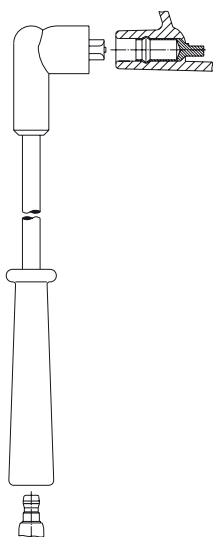

3A84/ 36  
 3A84/ 40  
 3A84/ 50  
 3A84/ 60  
 Verwendung für: /  
 applicable for:  
 KIA

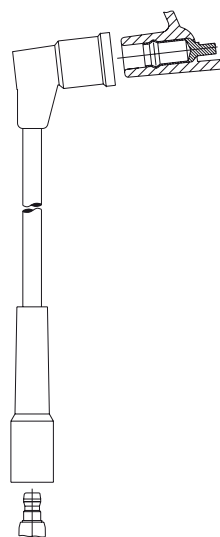

311/ 30  
 311/ 40  
 311/ 50  
 311/ 60  
 311/ 70  
 311/ 80  
 311/ 90  
 311/100  
 311/110  
 Verwendung für: /  
 applicable for:  
 ALFA ROMEO  
 ASIA MOTORS  
 AUDI  
 AUSTIN  
 CITROEN  
 DAIHATSU  
 FIAT  
 HONDA  
 HYUNDAI  
 LADA  
 LADA (Shiguli)  
 LANCIA  
 LAND ROVER  
 MAZDA  
 MG  
 MITSUBISHI  
 MORRIS  
 NISSAN  
 PEUGEOT  
 PROTON  
 RENAULT  
 ROVER  
 SAAB  
 SEAT  
 SKODA  
 SUBARU  
 SUZUKI  
 TALBOT  
 TOYOTA  
 TRIUMPH  
 ZASTAVA

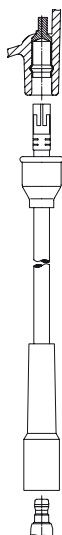

310/ 30  
 310/ 35  
 310/ 40  
 310/ 43  
 310/ 50  
 310/ 60  
 310/ 70  
 310/ 80  
 310/ 90  
 310/110  
 Verwendung für: /  
 applicable for:  
 ALFA ROMEO  
 AUTOBIANCHI  
 BEDFORD  
 CITROEN  
 DACIA  
 DAIHATSU  
 FIAT  
 FORD  
 HILLMANN  
 HONDA  
 HYUNDAI  
 INNOCENTI  
 ISUZU  
 LADA  
 LADA (Shiguli)  
 LANCIA  
 LAND ROVER  
 MAZDA  
 MITSUBISHI  
 NISSAN  
 OPEL  
 PEUGEOT  
 RENAULT  
 SEAT  
 SKODA  
 SUBARU  
 SUZUKI  
 TALBOT  
 TOYOTA  
 TRIUMPH  
 VAUXHALL  
 VOLVO  
 VW

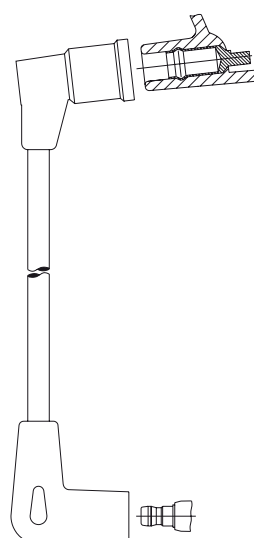

312/ 30  
 312/ 40  
 312/ 50  
 312/ 60  
 312/ 70  
 Verwendung für: /  
 applicable for:  
 AUSTIN  
 AUSTIN MORRIS  
 FIAT  
 HONDA  
 LANCIA  
 MG  
 MORRIS  
 RENAULT  
 ROVER

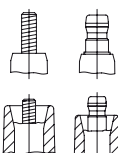

Connection spark plug: M4, SAE

Connection distributor cap: M4, SAE

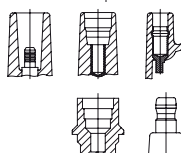

Connection distr. cap/ign. coil: 4 mm, Toyota 5 mm, DIN

Connection distr. cap/ign. coil: Ford, SAE



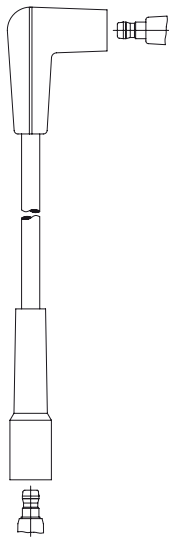

313/ 30  
 313/ 32  
 313/ 37  
 313/ 40  
 313/ 50  
 313/ 60  
 313/ 70  
 Verwendung für: /  
 applicable for:  
 CHRYSLER  
 CITROEN  
 OPEL  
 PEUGEOT  
 RENAULT  
 VAUXHALL



315/ 30  
 315/ 50  
 315/ 60  
 315/ 70  
 315/ 80  
 315/ 90  
 Verwendung für: /  
 applicable for:  
 AUTOBIANCHI  
 CITROEN  
 FIAT  
 OPEL  
 PEUGEOT  
 VAUXHALL

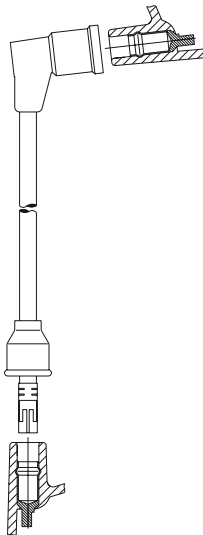

314/ 30  
 314/ 40  
 314/ 50  
 314/ 60  
 314/ 70  
 314/ 90  
 314/110  
 Verwendung für: /  
 applicable for:  
 ALFA ROMEO  
 ASIAM MOTORS  
 AUSTIN  
 AUSTIN MORRIS  
 AUTOBIANCHI  
 BEDFORD  
 CITROEN  
 DAIHATSU  
 FIAT  
 HILLMANN  
 HONDA  
 HYUNDAI  
 INNOCENTI  
 ISUZU  
 LADA (Shiguli)  
 LANCIA  
 LANDROVER  
 MAZDA  
 MG  
 MITSUBISHI  
 MORRIS  
 NISSAN  
 OPEL  
 PEUGEOT  
 PROTON  
 RENAULT  
 ROVER  
 SAAB  
 SEAT  
 SKODA  
 SUBARU

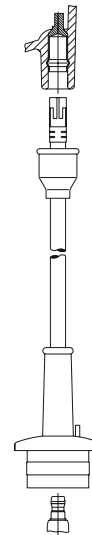

317/ 30  
 Verwendung für: /  
 applicable for:  
 TOYOTA



318/ 50  
 318/ 55  
 318/ 60  
 318/ 65  
 318/ 70  
 318/ 75  
 318/ 80  
 318/ 85  
 318/ 88  
 Verwendung für: /  
 applicable for:  
 OPEL

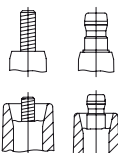

Connection spark plug: M4, SAE

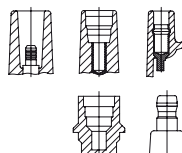

Connection distr. cap/ign. coil: 4 mm, Toyota 5 mm, DIN

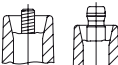

Connection distributor cap: M4, SAE



Connection distr. cap/ign. coil: Ford, SAE

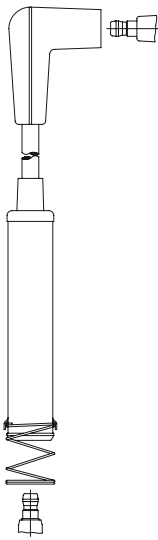

319/ 50  
319/ 60  
319/ 70  
319/ 80  
Verwendung für: /  
applicable for:  
OPEL  
VAUXHALL

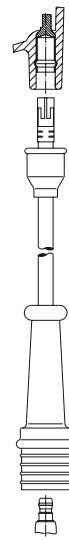

322/ 30  
322/ 40  
322/ 50  
322/ 70  
322/ 90  
322/130  
Verwendung für: /  
applicable for:  
ALFA ROMEO  
CITROEN  
RENAULT

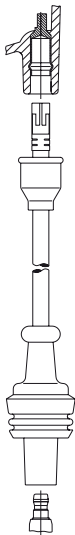

320/ 30  
320/ 40  
320/ 60  
320/ 80  
320/100  
320/110  
Verwendung für: /  
applicable for:  
CITROEN  
PEUGEOT  
RENAULT

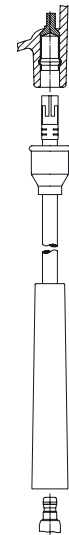

323/ 40  
323/ 45  
323/ 49  
323/ 50  
323/ 60  
323/ 64  
323/ 68  
323/ 70  
323/ 80  
323/ 90  
323/110  
Verwendung für: /  
applicable for:  
FIAT  
HYUNDAI  
LADA (Shiguli)  
MAZDA  
MITSUBISHI  
NISSAN  
PEUGEOT  
SEAT  
SUZUKI  
TOYOTA



321/ 30  
321/ 40  
321/ 50  
321/ 60  
321/ 80  
Verwendung für: /  
applicable for:  
PEUGEOT  
RENAULT

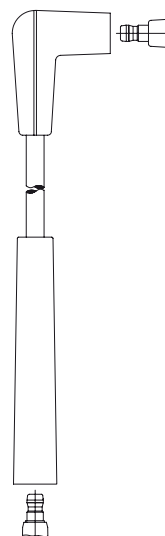

324/ 40  
324/ 50  
324/ 60  
Verwendung für: /  
applicable for:  
RENAULT

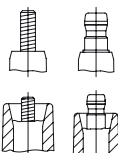

Connection spark plug: M4, SAE

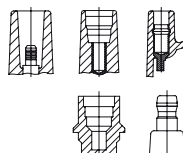

Connection distr. cap/ign. coil: 4 mm, Toyota 5 mm, DIN

Connection distributor cap: M4, SAE

Connection distr. cap/ign. coil: Ford, SAE

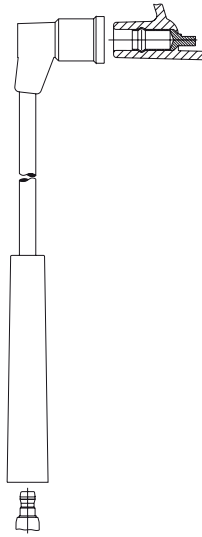

326/ 40  
326/ 45  
326/ 60  
326/ 65  
Verwendung für: /  
applicable for:  
KIA

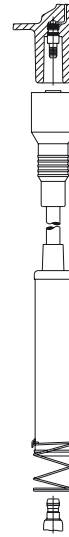

328/ 60  
328/ 80  
Verwendung für: /  
applicable for:  
OPEL  
VAUXHALL

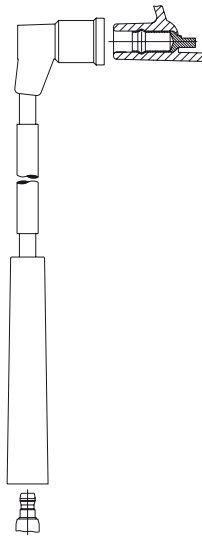

326E 60  
Verwendung für: /  
applicable for:  
KIA

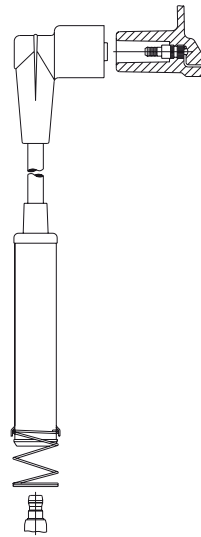

329/ 25  
329/ 40  
329/ 46  
329/ 60  
329/ 70  
329/ 80  
Verwendung für: /  
applicable for:  
OPEL  
VAUXHALL

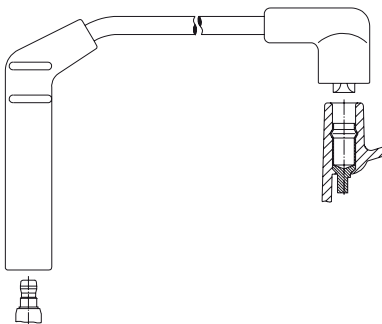

327/ 24  
327/ 27  
327/ 32  
327/ 34  
327/ 40  
327/ 45  
327/ 49  
327/ 52  
Verwendung für: /  
applicable for:  
HYUNDAI

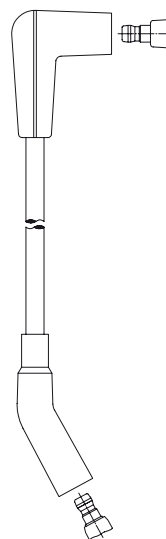

337/ 24  
337/ 27  
Verwendung für: /  
applicable for:  
CHRYSLER

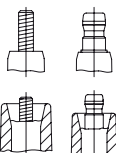

Connection spark plug: M4, SAE

Connection distributor cap: M4, SAE

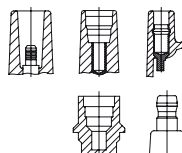

Connection distr. cap/ign. coil: 4 mm, Toyota 5 mm, DIN

Connection distr. cap/ign. coil: Ford, SAE

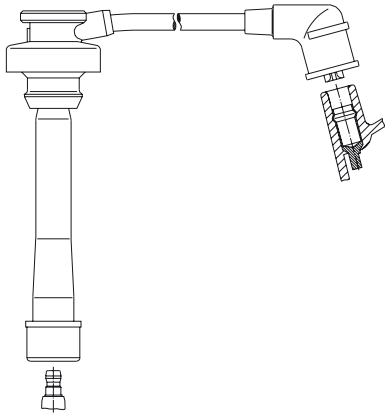

338/ 26  
 338/ 37  
 338/ 40  
 338/ 42  
 338/ 45  
 338/ 50  
 338/ 52  
 338/ 55  
 338/ 57  
 338/ 60  
 338/ 62  
 338/ 70  
 Verwendung für: /  
 applicable for:  
 MITSUBISHI  
 PROTON

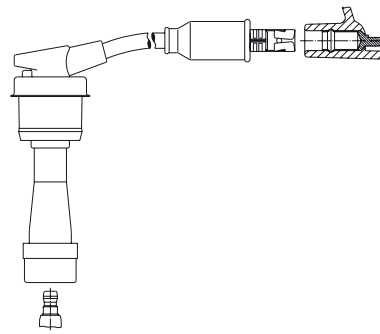

347/ 32  
 347/ 38  
 347/ 44  
 347/ 53  
 347/ 57  
 347/ 61  
 347/ 67  
 Verwendung für: /  
 applicable for:  
 HYUNDAI  
 KIA  
 MITSUBISHI

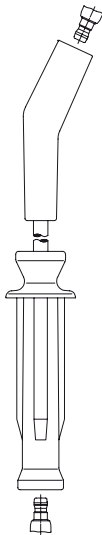

339/ 48  
 339/ 64  
 339/ 70  
 339/ 72  
 Verwendung für: /  
 applicable for:  
 LAND ROVER

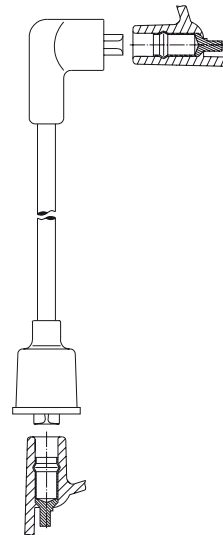

348/ 32  
 348/ 46  
 Verwendung für: /  
 applicable for:  
 HYUNDAI

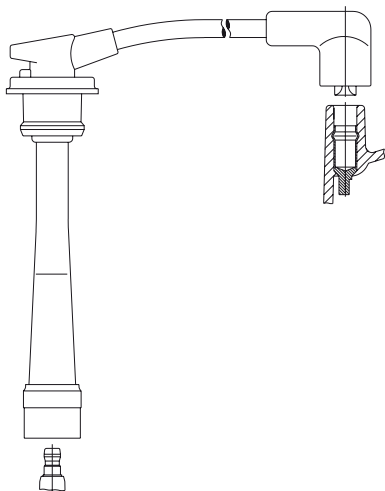

346/ 23  
 346/ 32  
 346/ 40  
 346/ 54  
 Verwendung für: /  
 applicable for:  
 HYUNDAI

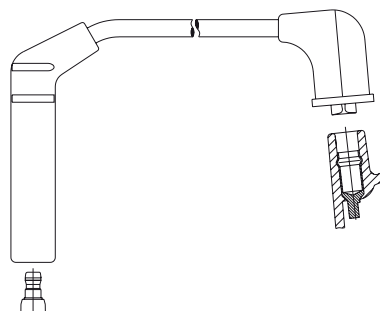

349/ 38  
 349/ 40  
 349/ 45  
 349/ 47  
 349/ 48  
 349/ 53  
 349/ 55  
 349/ 57  
 349/ 59  
 349/ 62  
 349/ 65  
 349/ 67  
 349/ 72  
 349/ 77  
 349/ 80  
 349/ 82  
 Verwendung für: /  
 applicable for:  
 CHRYSLER  
 DAEWOO  
 HYUNDAI  
 MITSUBISHI

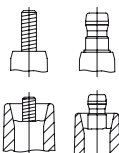

Connection spark plug: M4, SAE

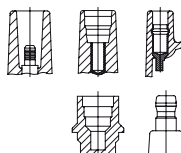

Connection distr. cap/ign. coil: 4 mm, Toyota 5 mm, DIN

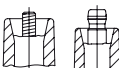

Connection distributor cap: M4, SAE



Connection distr. cap/ign. coil: Ford, SAE

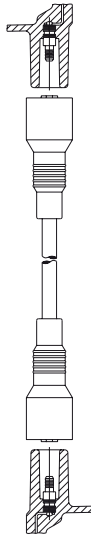

350/ 50  
350/ 60  
350/100  
Verwendung für: /  
applicable for:  
OPEL  
VAUXHALL

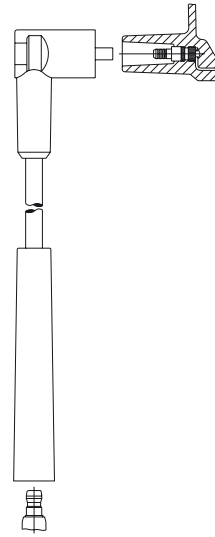

352/ 30  
352/ 40  
352/ 45  
352/ 65  
Verwendung für: /  
applicable for:  
KIA

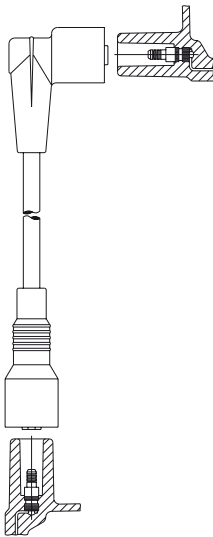

351/ 26  
351/ 30  
351/ 41  
351/ 50  
351/ 51  
351/ 55  
351/ 60  
Verwendung für: /  
applicable for:  
HOLDEN  
OPEL  
VAUXHALL

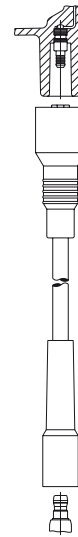

353/ 40  
353/ 50  
353/ 60  
353/ 70  
353/ 80  
353/ 90  
353/100  
Verwendung für: /  
applicable for:  
OPEL  
VAUXHALL

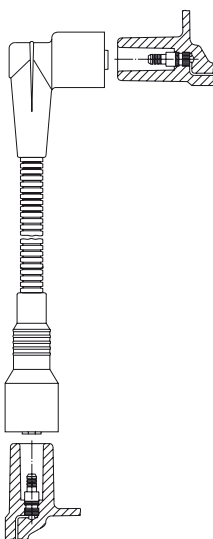

351E 26  
Verwendung für: /  
applicable for:  
OPEL

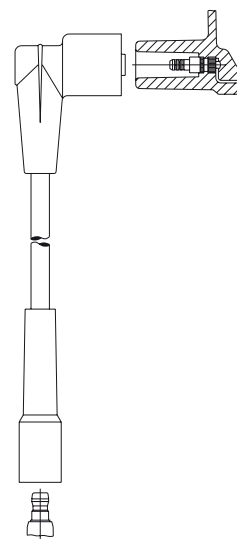

354/ 30  
354/ 40  
354/ 50  
354/ 70  
Verwendung für: /  
applicable for:  
OPEL  
VAUXHALL

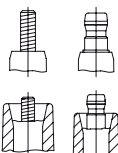

Connection spark plug: M4, SAE

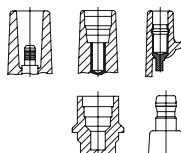

Connection distr. cap/ign. coil: 4 mm, Toyota 5 mm, DIN

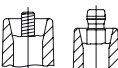

Connection distributor cap: M4, SAE



Connection distr. cap/ign. coil: Ford, SAE

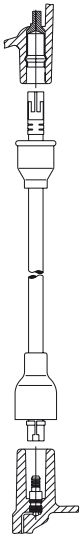

355/ 30  
355/ 32  
355/ 40  
355/ 70  
355/100  
Verwendung für: /  
applicable for:  
CITROEN  
OPEL

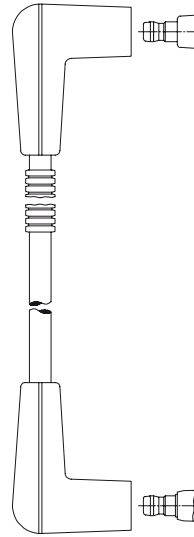

358E 96  
Verwendung für: /  
applicable for:  
CHRYSLER

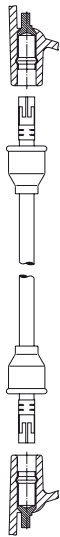

357/ 20  
357/ 34  
Verwendung für: /  
applicable for:  
SUZUKI

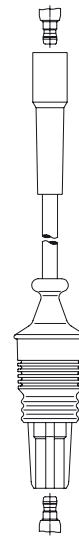

359/ 50  
359/ 60  
359/ 70  
Verwendung für: /  
applicable for:  
PEUGEOT

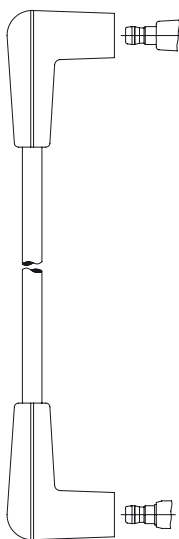

358/ 25  
358/ 26  
358/ 36  
358/ 86  
Verwendung für: /  
applicable for:  
CHRYSLER  
OPEL

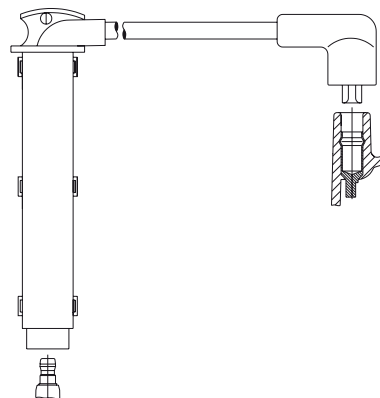

361/ 29  
361/ 33  
361/ 43  
361/ 50  
Verwendung für: /  
applicable for:  
ROVER

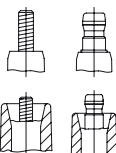

Connection spark plug: M4, SAE

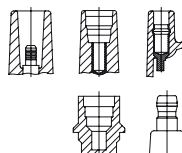

Connection distr. cap/ign. coil: 4 mm, Toyota 5 mm, DIN

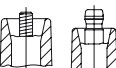

Connection distributor cap: M4, SAE



Connection distr. cap/ign. coil: Ford, SAE

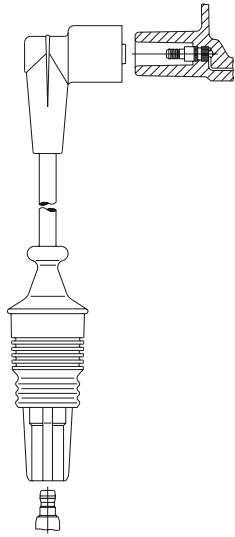

363/ 30  
 363/ 60  
 363/ 65  
 363/ 85  
 363/ 90  
 363/100  
 Verwendung für: /  
 applicable for:  
 CITROEN

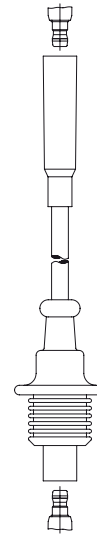

367/ 70  
 367/ 80  
 Verwendung für: /  
 applicable for:  
 PEUGEOT

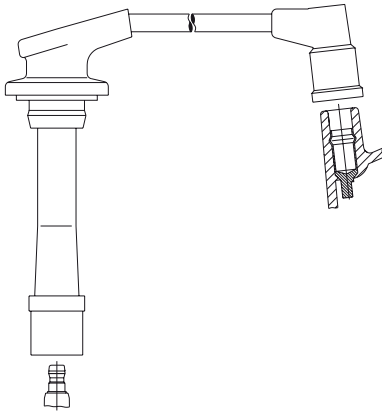

364/ 40  
 364/ 50  
 364/ 60  
 364/ 70  
 Verwendung für: /  
 applicable for:  
 HONDA

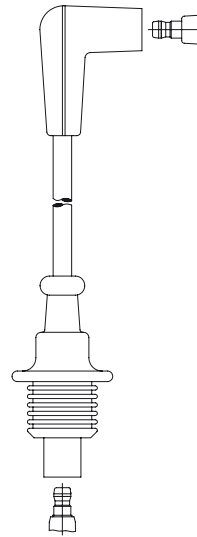

368/ 50  
 368/ 60  
 Verwendung für: /  
 applicable for:  
 PEUGEOT

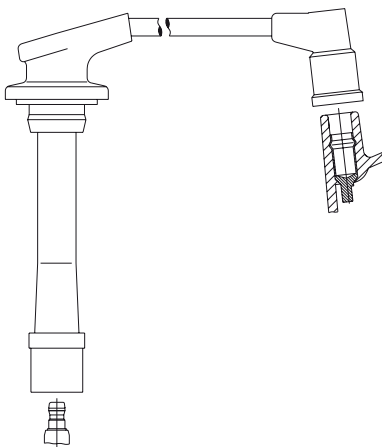

365/ 40  
 365/ 50  
 365/ 60  
 365/ 70  
 Verwendung für: /  
 applicable for:  
 HONDA

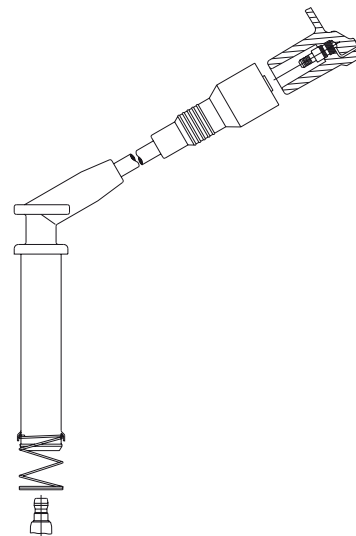

369/ 40  
 369/ 60  
 Verwendung für: /  
 applicable for:  
 OPEL  
 VAUXHALL

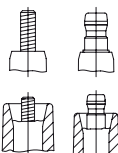

Connection spark plug: M4, SAE

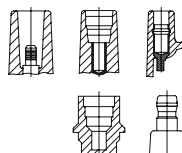

Connection distr. cap/ign. coil: 4 mm, Toyota 5 mm, DIN

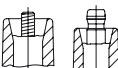

Connection distributor cap: M4, SAE



Connection distr. cap/ign. coil: Ford, SAE

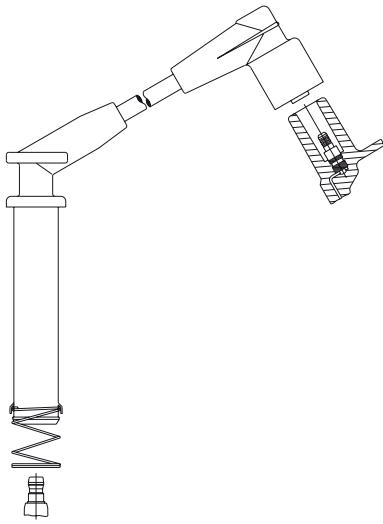

370/ 18  
 370/ 20  
 370/ 27  
 370/ 30  
 370/ 35  
 370/ 36  
 370/ 40  
 370/ 42  
 370/ 43  
 370/ 44  
 370/ 50  
 370/ 56  
 370/ 59  
 370/ 60  
 370/ 66  
 Verwendung für: /  
 applicable for:  
 HOLDEN  
 OPEL  
 VAUXHALL

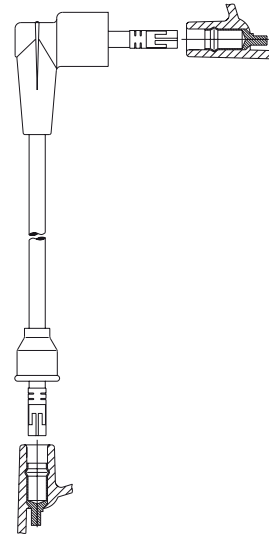

374/ 46  
 Verwendung für: /  
 applicable for:  
 KIA

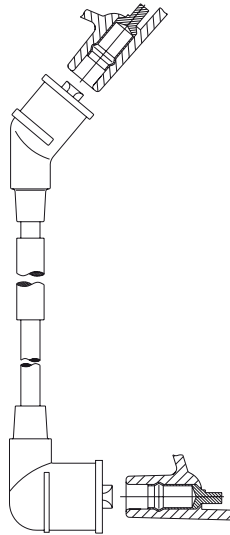

371E 34  
 Verwendung für: /  
 applicable for:  
 NISSAN

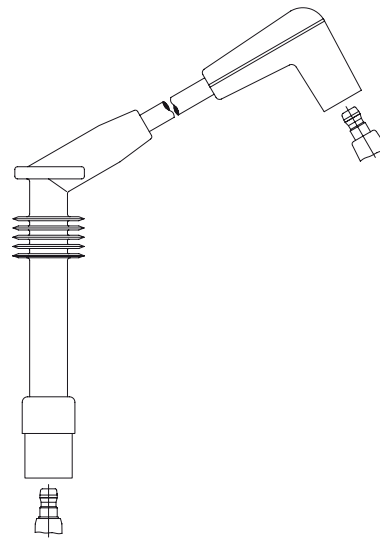

375/ 33  
 375/ 38  
 375/ 40  
 375/ 55  
 375/ 56  
 375/ 60  
 375/ 62  
 Verwendung für: /  
 applicable for:  
 OPEL

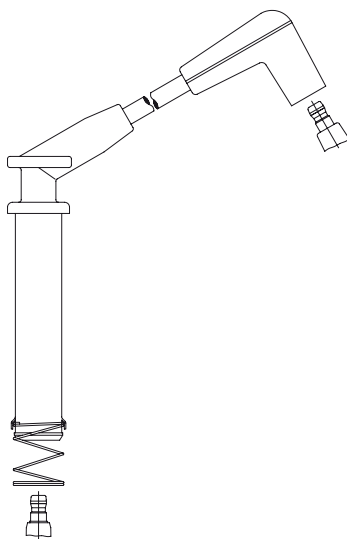

373/ 33  
 373/ 40  
 373/ 56  
 373/ 62  
 Verwendung für: /  
 applicable for:  
 OPEL



377/ 41  
 Verwendung für: /  
 applicable for:  
 KIA

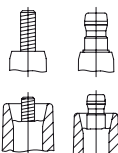

Connection spark plug: M4, SAE

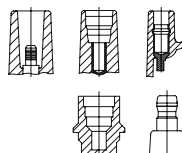

Connection distr. cap/ign. coil: 4 mm, Toyota 5 mm, DIN

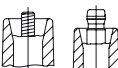

Connection distributor cap: M4, SAE



Connection distr. cap/ign. coil: Ford, SAE



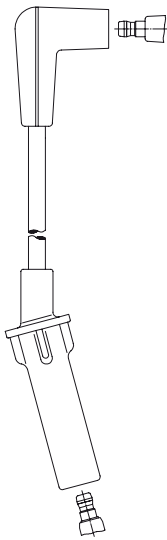

378/ 49  
378/ 63  
378/ 68  
378/ 80  
Verwendung für: /  
applicable for:  
CHRYSLER

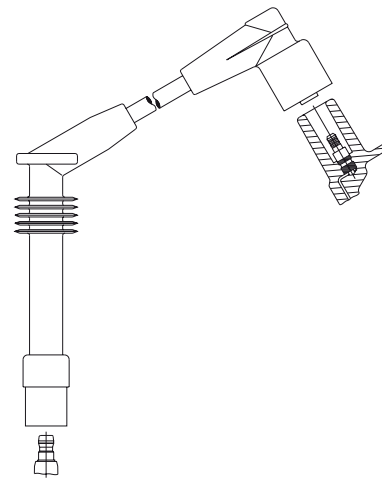

379S 24  
379S 40  
379S 44  
379S 48  
Verwendung für: /  
applicable for:  
OPEL  
VAUXHALL

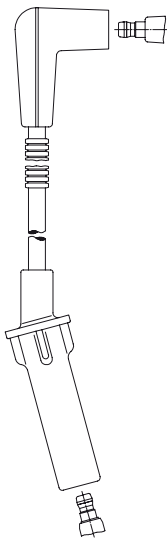

378E 48  
378E 52  
378E 62  
378E 69  
378E 76  
378E 77  
378E 80  
Verwendung für: /  
applicable for:  
CHRYSLER

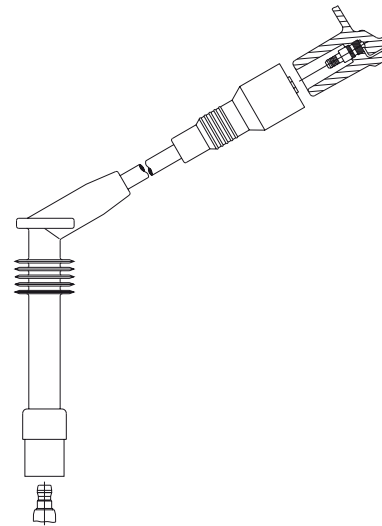

380/ 32  
380/ 54  
Verwendung für: /  
applicable for:  
HOLDEN  
OPEL  
VAUXHALL

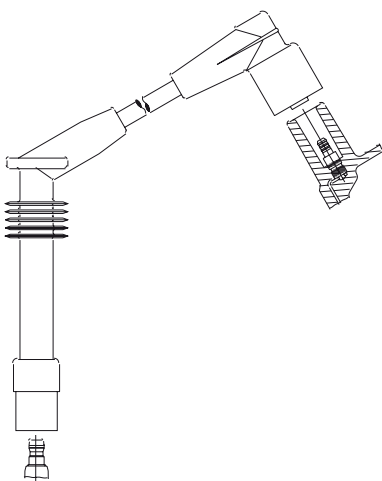

379/ 18  
379/ 27  
379/ 32  
379/ 34  
379/ 35  
379/ 39  
379/ 43  
379/ 46  
379/ 52  
379/ 53  
379/ 57  
379/ 61  
379/ 65  
379/ 68  
379/ 71  
379/ 81  
Verwendung für: /  
applicable for:  
HOLDEN  
OPEL  
VAUXHALL

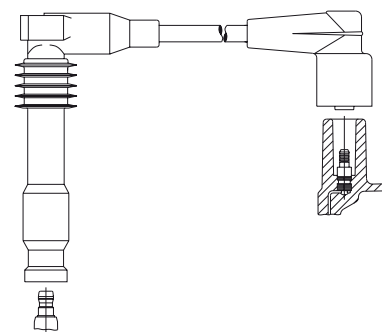

381/ 18  
381/ 24  
381/ 33  
381/ 36  
381/ 44  
381/ 48  
381/ 52  
381/ 55  
381/ 63  
381/ 65  
381/ 77  
Verwendung für: /  
applicable for:  
CHEVROLET  
DAEWOO  
HOLDEN  
OPEL  
SAAB  
VAUXHALL

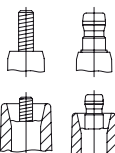

Connection spark plug: M4, SAE

Connection distributor cap: M4, SAE

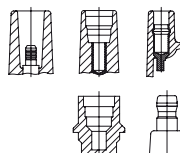

Connection distr. cap/ign. coil: 4 mm, Toyota 5 mm, DIN

Connection distr. cap/ign. coil: Ford, SAE

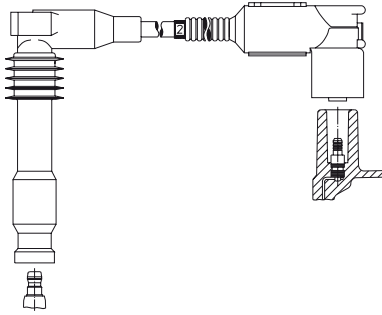

381K 36  
381K 43  
Verwendung für: /  
applicable for:  
OPEL

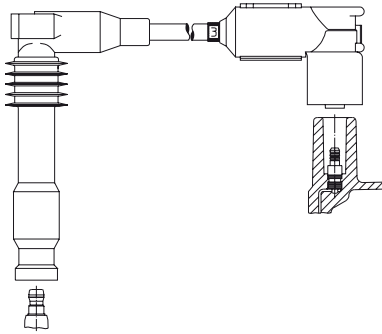

381M 18  
381M 23  
Verwendung für: /  
applicable for:  
OPEL

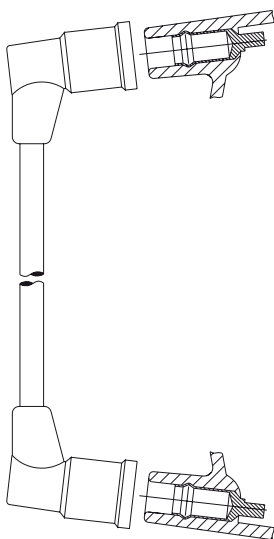

383/ 35  
Verwendung für: /  
applicable for:  
SUZUKI

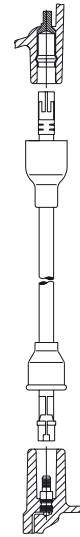

384/ 25  
Verwendung für: /  
applicable for:  
OPEL



385/ 40  
Verwendung für: /  
applicable for:  
OPEL

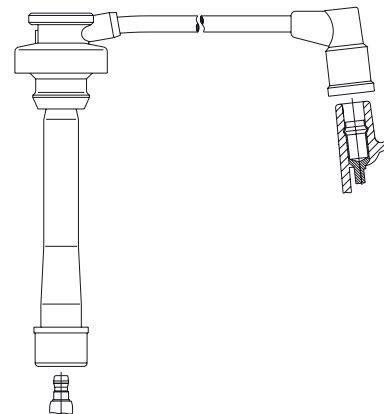

386/ 30  
386/ 38  
386/ 40  
386/ 45  
386/ 58  
386/ 60  
386/ 65  
386/ 75  
Verwendung für: /  
applicable for:  
MITSUBISHI

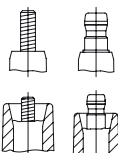

Connection spark plug: M4, SAE

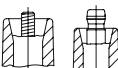

Connection distributor cap: M4, SAE

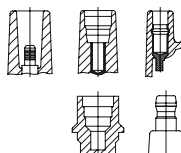

Connection distr. cap/ign. coil: 4 mm, Toyota 5 mm, DIN



Connection distr. cap/ign. coil: Ford, SAE

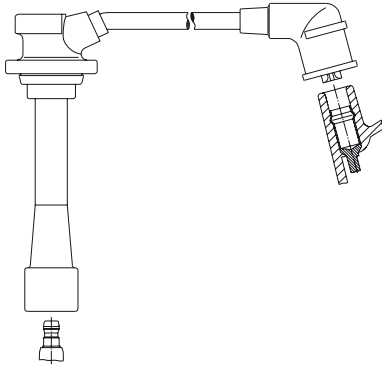

388/ 30  
388/ 45  
388/ 50  
388/ 60  
Verwendung für: /  
applicable for:  
KIA

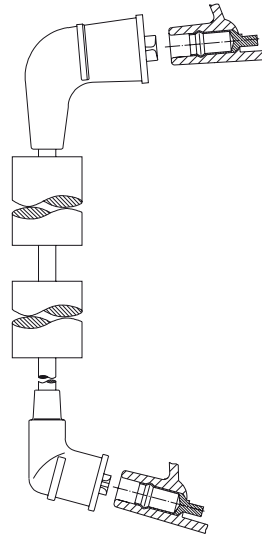

389F 70  
Verwendung für: /  
applicable for:  
MITSUBISHI

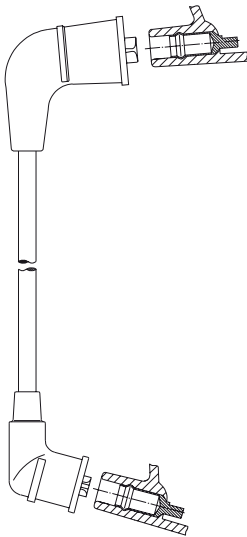

389/ 23  
389/ 30  
389/ 52  
389/ 60  
Verwendung für: /  
applicable for:  
HYUNDAI  
MITSUBISHI

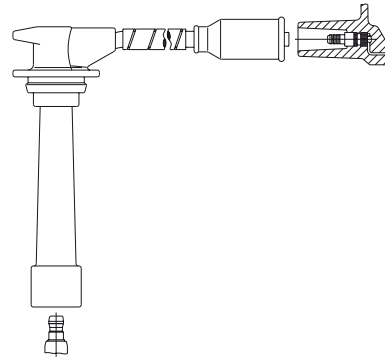

390/ 26  
Verwendung für: /  
applicable for:  
KIA

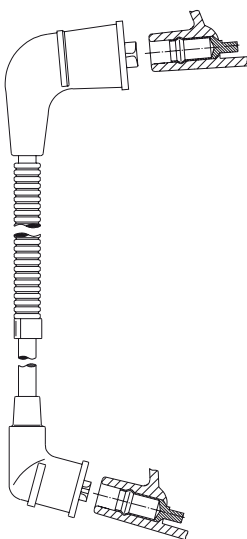

389E 55  
Verwendung für: /  
applicable for:  
KIA



391/ 20  
Verwendung für: /  
applicable for:  
KIA

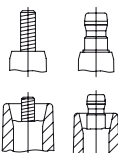

Connection spark plug: M4, SAE

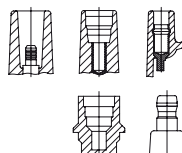

Connection distr. cap/ign. coil: 4 mm, Toyota 5 mm, DIN

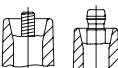

Connection distributor cap: M4, SAE



Connection distr. cap/ign. coil: Ford, SAE

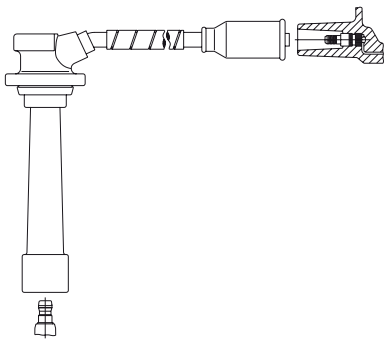

392/ 25  
Verwendung für: /  
applicable for:  
KIA

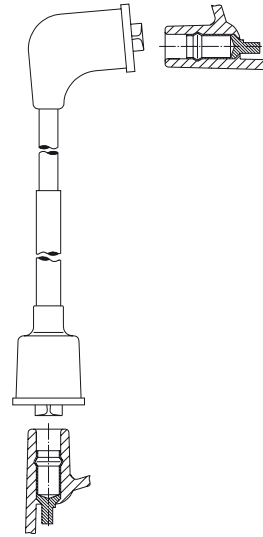

396E 22  
Verwendung für: /  
applicable for:  
MAZDA

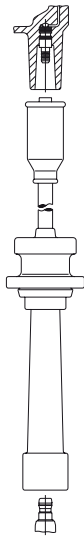

393/ 20  
Verwendung für: /  
applicable for:  
KIA

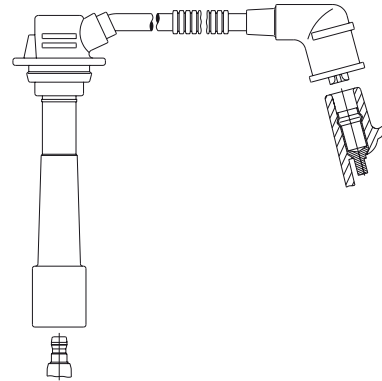

397E 54  
Verwendung für: /  
applicable for:  
MAZDA

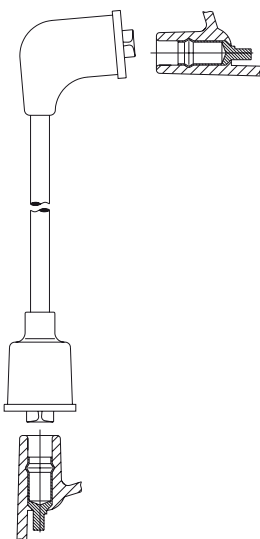

396/ 14  
396/ 16  
396/ 18  
396/ 25  
396/ 47  
Verwendung für: /  
applicable for:  
CHRYSLER  
DAIHATSU  
DODGE  
MITSUBISHI

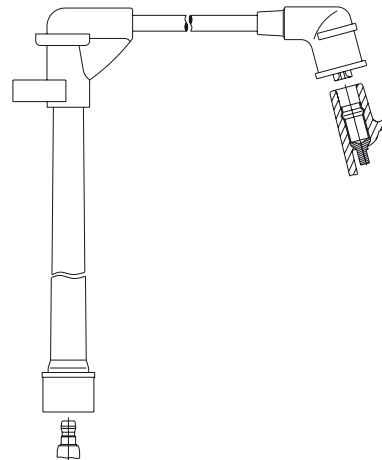

398/ 67  
Verwendung für: /  
applicable for:  
NISSAN

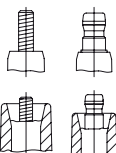

Connection spark plug: M4, SAE

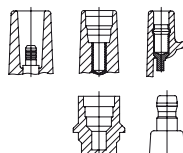

Connection distr. cap/ign. coil: 4 mm, Toyota 5 mm, DIN

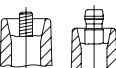

Connection distributor cap: M4, SAE



Connection distr. cap/ign. coil: Ford, SAE

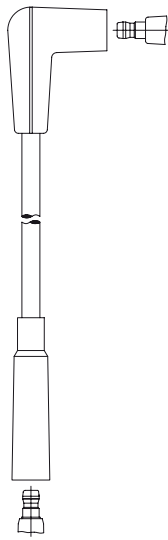

401/ 32  
401/ 48  
Verwendung für: /  
applicable for:  
CHRYSLER  
DAEWOO

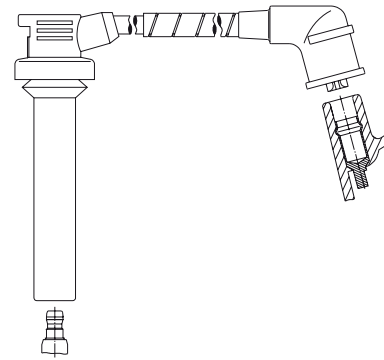

403E 35  
403E 52  
Verwendung für: /  
applicable for:  
MAZDA

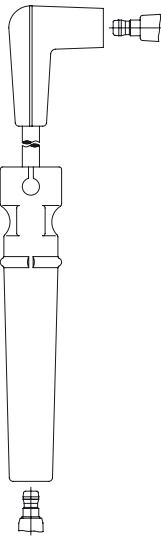

402/ 48  
402/ 55  
402/ 62  
402/ 69  
Verwendung für: /  
applicable for:  
DAEWOO

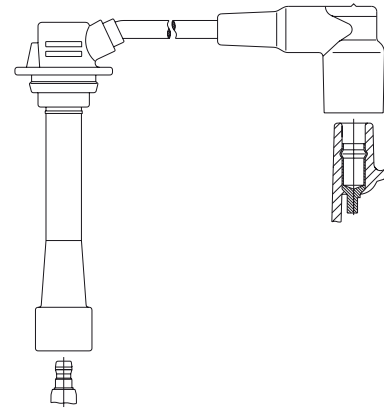

408/ 18  
408/ 26  
408/ 30  
408/ 36  
408/ 40  
Verwendung für: /  
applicable for:  
MAZDA

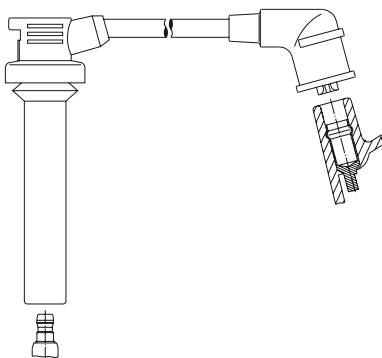

403/ 31  
403/ 49  
Verwendung für: /  
applicable for:  
MAZDA

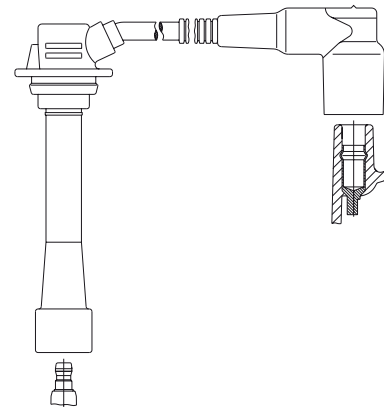

408E 14  
408E 17  
408E 22  
Verwendung für: /  
applicable for:  
MAZDA

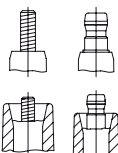

Connection spark plug: M4, SAE

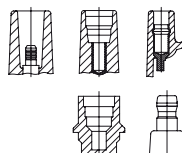

Connection distr. cap/ign. coil: 4 mm, Toyota 5 mm, DIN

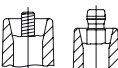

Connection distributor cap: M4, SAE



Connection distr. cap/ign. coil: Ford, SAE

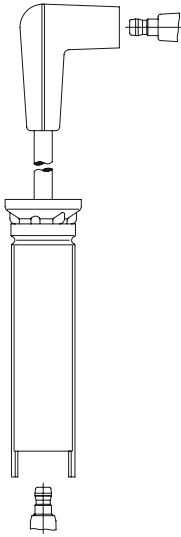

426/ 53  
 426/ 62  
 426/ 70  
 426/ 79  
 426/ 90  
 Verwendung für: /  
 applicable for:  
 DAEWOO

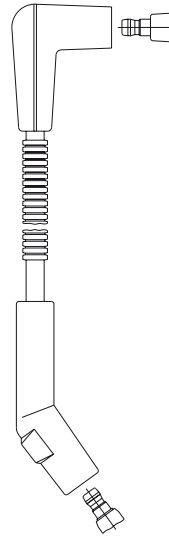

428E 47  
 Verwendung für: /  
 applicable for:  
 DAEWOO

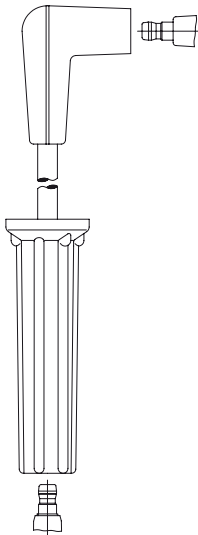

427/ 58  
 Verwendung für: /  
 applicable for:  
 DAEWOO

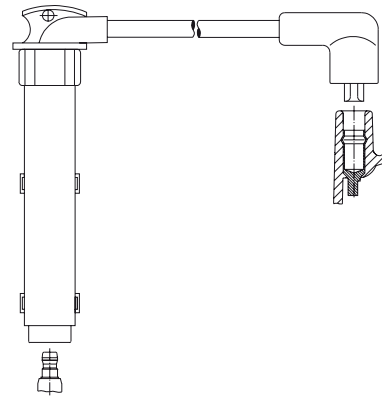

429/ 30  
 429/ 33  
 429/ 43  
 429/ 50  
 Verwendung für: /  
 applicable for:  
 LAND ROVER  
 ROVER

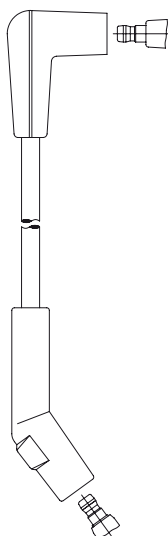

428/ 37  
 Verwendung für: /  
 applicable for:  
 DAEWOO

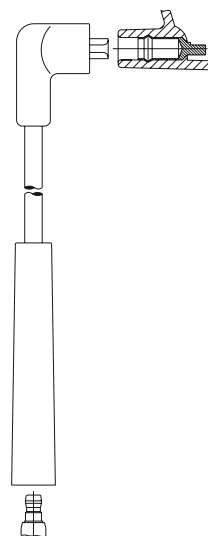

430/ 45  
 Verwendung für: /  
 applicable for:  
 ROVER

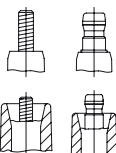

Connection spark plug: M4, SAE

Connection distributor cap: M4, SAE

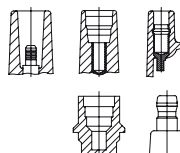

Connection distr. cap/ign. coil: 4 mm, Toyota 5 mm, DIN

Connection distr. cap/ign. coil: Ford, SAE

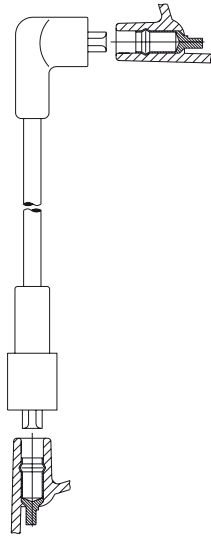

433/ 34  
433/ 50  
433/ 54  
433/ 73  
433/ 80  
Verwendung für: /  
applicable for:  
HONDA  
LAND ROVER  
ROVER

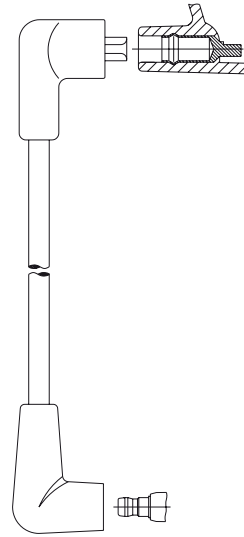

445/ 28  
445/ 30  
445/ 33  
445/ 40  
445/ 49  
445/ 53  
445/ 63  
Verwendung für: /  
applicable for:  
AUSTIN  
CHRYSLER  
ROVER

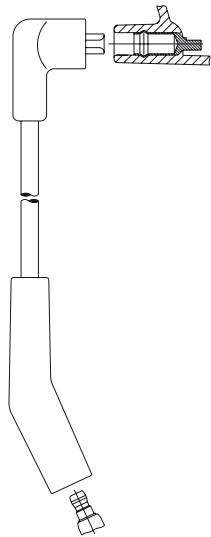

437/ 38  
437/ 40  
437/ 51  
437/ 55  
437/ 57  
437/ 59  
437/ 67  
437/ 76  
437/ 81  
Verwendung für: /  
applicable for:  
HONDA  
LAND ROVER  
ROVER

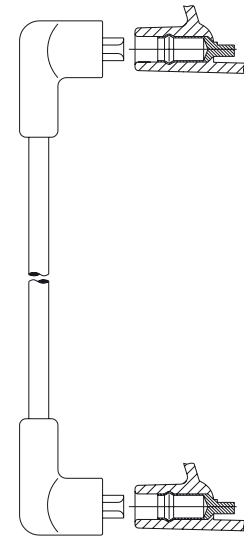

446/ 24  
446/ 33  
446/ 45  
Verwendung für: /  
applicable for:  
AUSTIN  
ROVER

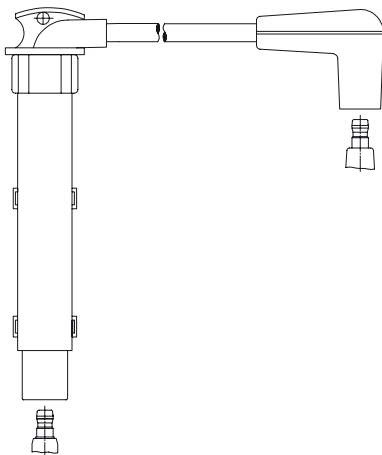

441/ 79  
441/ 90  
441/ 98  
441/102  
Verwendung für: /  
applicable for:  
ROVER

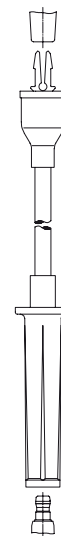

447/ 31  
447/ 36  
Verwendung für: /  
applicable for:  
CHRYSLER

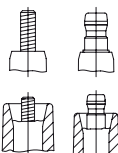

Connection spark plug: M4, SAE

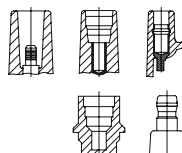

Connection distr. cap/ign. coil: 4 mm, Toyota 5 mm, DIN

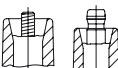

Connection distributor cap: M4, SAE



Connection distr. cap/ign. coil: Ford, SAE

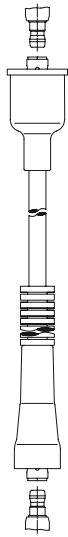

448E 70  
Verwendung für: /  
applicable for:  
CHRYSLER

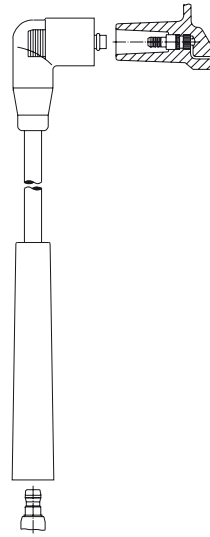

461/ 25  
461/ 33  
Verwendung für: /  
applicable for:  
ROVER

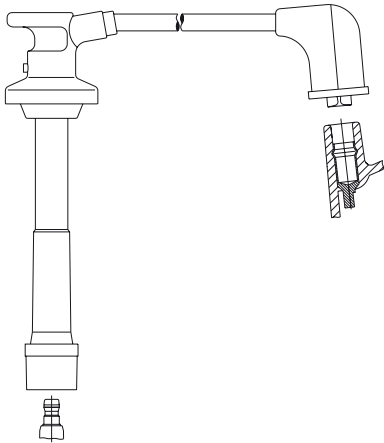

449/ 31  
449/ 42  
Verwendung für: /  
applicable for:  
MAZDA

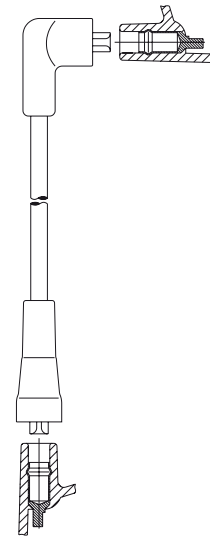

463/ 45  
463/ 50  
Verwendung für: /  
applicable for:  
ROVER

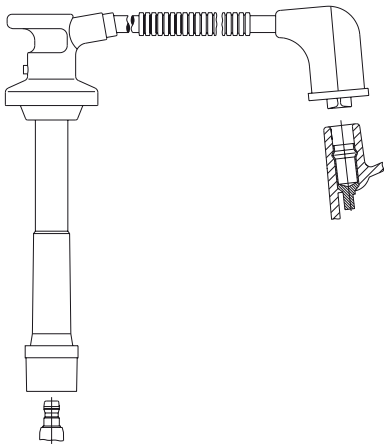

449E 62  
Verwendung für: /  
applicable for:  
MAZDA

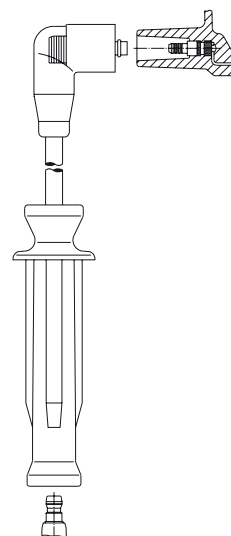

465/ 39  
465/ 44  
465/ 52  
465/ 61  
465/ 66  
465/ 73  
465/ 84  
465/ 91  
Verwendung für: /  
applicable for:  
ROVER

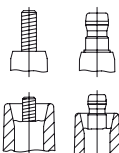

Connection spark plug: M4, SAE

Connection distributor cap: M4, SAE

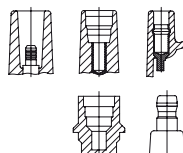

Connection distr. cap/ign. coil: 4 mm, Toyota 5 mm, DIN

Connection distr. cap/ign. coil: Ford, SAE



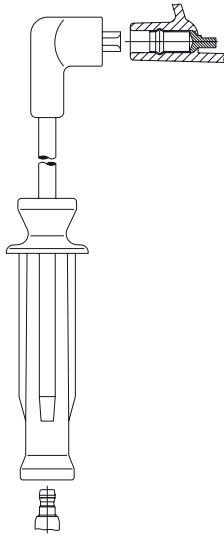

466/ 37  
 466/ 38  
 466/ 52  
 466/ 54  
 466/ 66  
 Verwendung für: /  
 applicable for:  
 ROVER

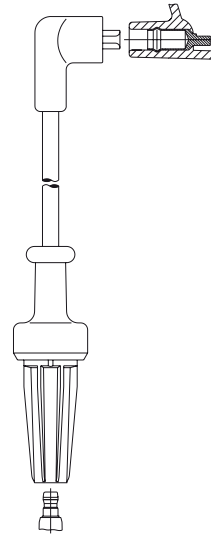

470/ 36  
 470/ 48  
 470/ 51  
 470/ 62  
 Verwendung für: /  
 applicable for:  
 ROVER

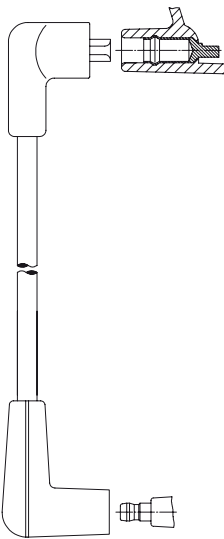

468/ 26  
 468/ 35  
 468/ 47  
 468/ 55  
 468/ 60  
 468/ 67  
 Verwendung für: /  
 applicable for:  
 ROVER

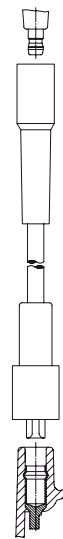

471/ 50  
 471/ 55  
 471/ 58  
 Verwendung für: /  
 applicable for:  
 LAND ROVER

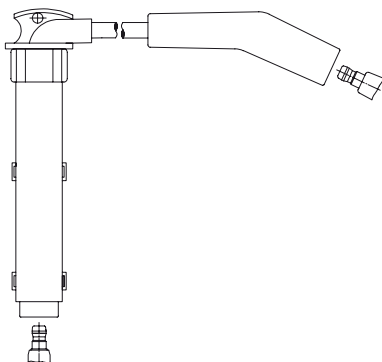

469/ 33  
 469/ 48  
 469/ 60  
 469/ 86  
 469/ 96  
 Verwendung für: /  
 applicable for:  
 ROVER

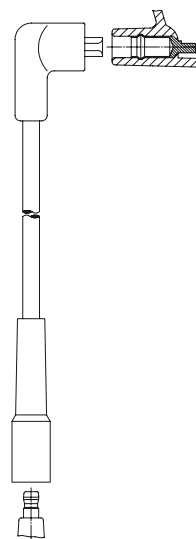

474/ 25  
 474/ 62  
 474/ 70  
 474/ 73  
 474/ 76  
 474/ 84  
 Verwendung für: /  
 applicable for:  
 LAND ROVER

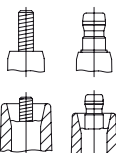

Connection spark plug: M4, SAE

Connection distributor cap: M4, SAE

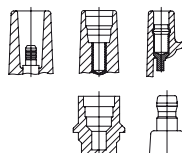

Connection distr. cap/ign. coil: 4 mm, Toyota 5 mm, DIN

Connection distr. cap/ign. coil: Ford, SAE

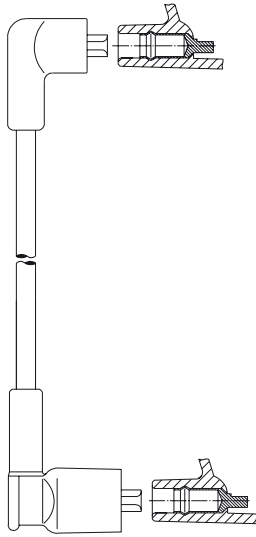

478/ 20  
Verwendung für: /  
applicable for:  
LAND ROVER

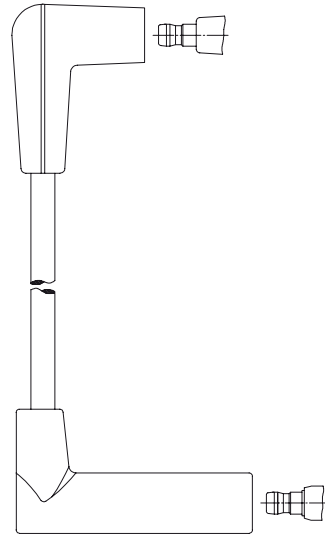

481/ 20  
481/ 28  
481/ 33  
Verwendung für: /  
applicable for:  
CHRYSLER

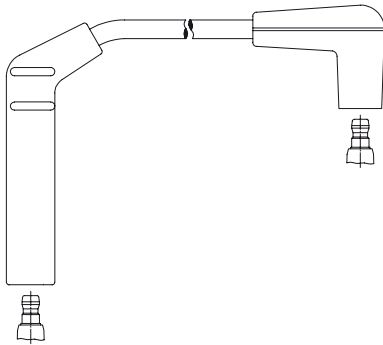

480/ 29  
480/ 44  
480/ 59  
Verwendung für: /  
applicable for:  
CHRYSLER  
DODGE

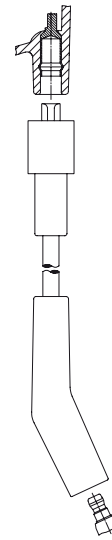

483/ 59  
483/ 67  
483/ 73  
Verwendung für: /  
applicable for:  
LAND ROVER

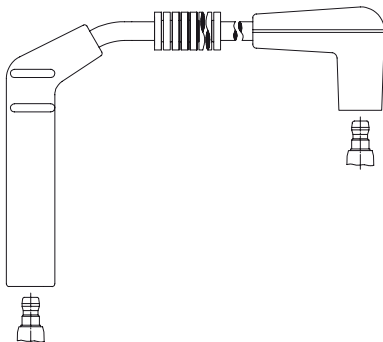

480E 44  
480E 61  
Verwendung für: /  
applicable for:  
CHRYSLER  
DODGE

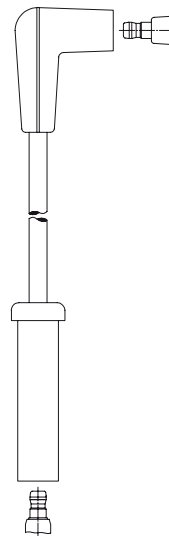

484/ 26  
484/ 29  
484/ 38  
484/ 43  
Verwendung für: /  
applicable for:  
CHRYSLER

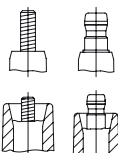

Connection spark plug: M4, SAE

Connection distributor cap: M4, SAE

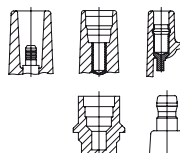

Connection distr. cap/ign. coil: 4 mm, Toyota 5 mm, DIN

Connection distr. cap/ign. coil: Ford, SAE

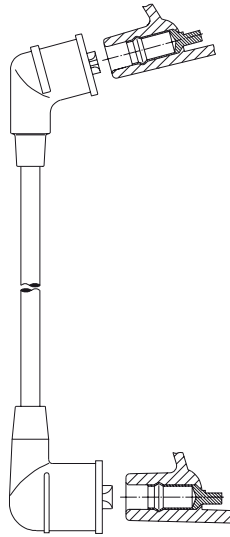

486/ 23  
486/ 40  
486/ 52  
Verwendung für: /  
applicable for:  
MITSUBISHI  
NISSAN  
SUBARU

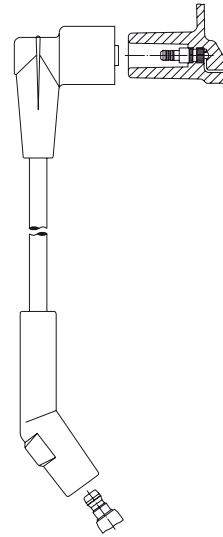

489/ 32  
Verwendung für: /  
applicable for:  
CHEVROLET  
DAEWOO

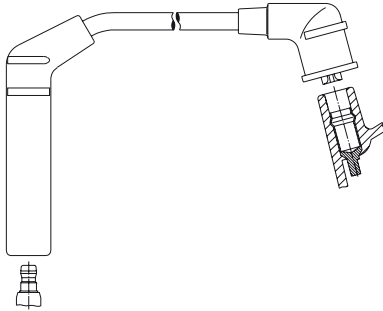

487/ 27  
487/ 33  
487/ 40  
487/ 47  
487/ 48  
487/ 50  
487/ 54  
487/ 56  
487/ 62  
487/ 64  
487/ 67  
487/ 72  
487/ 82  
Verwendung für: /  
applicable for:  
MITSUBISHI  
SUBARU

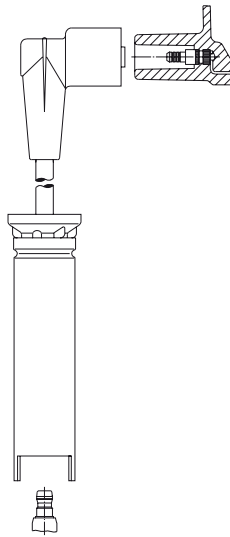

490/ 38  
490/ 46  
490/ 51  
Verwendung für: /  
applicable for:  
CHEVROLET  
DAEWOO

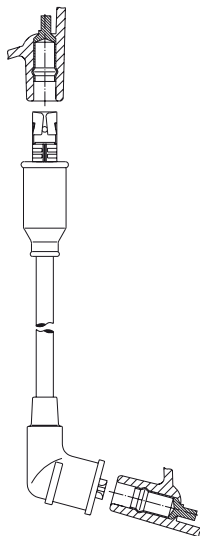

488/ 84  
Verwendung für: /  
applicable for:  
SUBARU

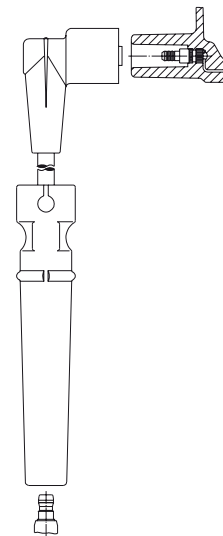

491/ 36  
491/ 40  
491/ 46  
491/ 52  
Verwendung für: /  
applicable for:  
CHEVROLET  
DAEWOO

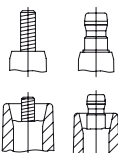

Connection spark plug: M4, SAE

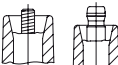

Connection distributor cap: M4, SAE

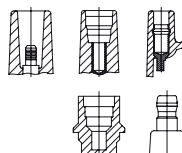

Connection distr. cap/ign. coil: 4 mm, Toyota 5 mm, DIN

Connection distr. cap/ign. coil: Ford, SAE

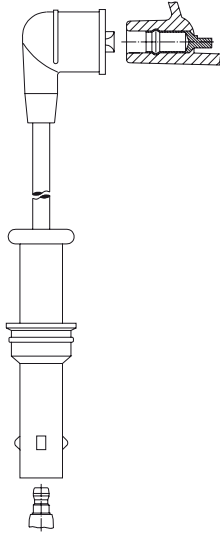

492/ 62  
492/ 66  
Verwendung für: /  
applicable for:  
SUBARU

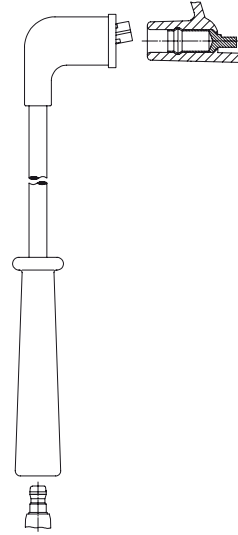

495/ 64  
495/ 66  
495/ 69  
495/ 71  
495/ 75  
495/ 82  
495/ 87  
495/ 95  
Verwendung für: /  
applicable for:  
MITSUBISHI  
SUZUKI

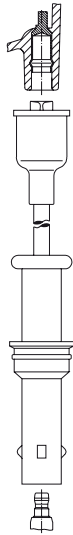

493/ 60  
Verwendung für: /  
applicable for:  
SUBARU

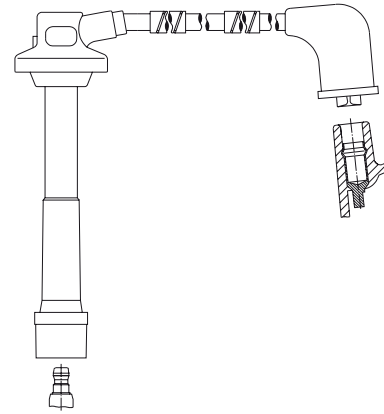

496F 59  
Verwendung für: /  
applicable for:  
FORD

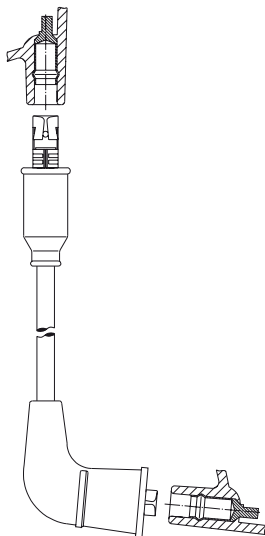

494/ 32  
Verwendung für: /  
applicable for:  
MITSUBISHI

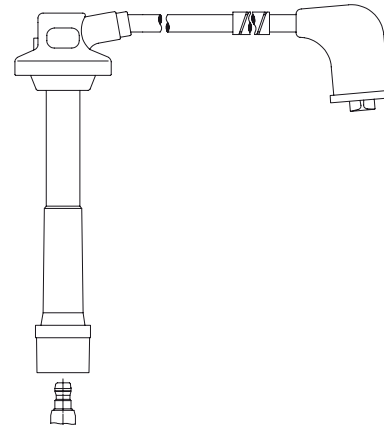

496H 41  
Verwendung für: /  
applicable for:  
FORD

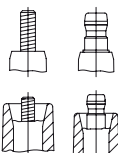

Connection spark plug: M4, SAE

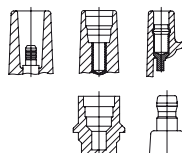

Connection distr. cap/ign. coil: 4 mm, Toyota 5 mm, DIN

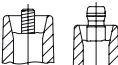

Connection distributor cap: M4, SAE



Connection distr. cap/ign. coil: Ford, SAE

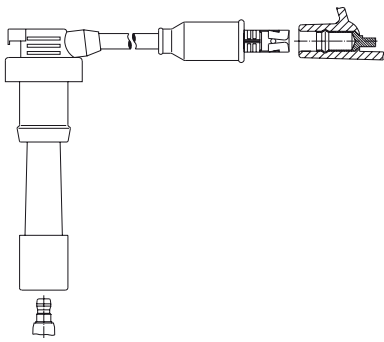

497/ 35  
 497/ 46  
 497/ 57  
 497/ 60  
 Verwendung für: /  
 applicable for:  
 MITSUBISHI

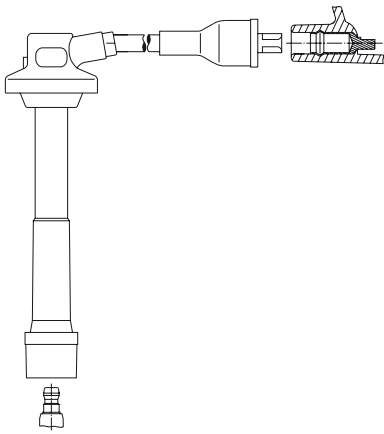

499/ 40  
 499/ 56  
 Verwendung für: /  
 applicable for:  
 FORD

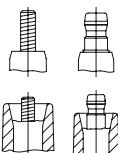

Connection spark plug: M4, SAE

Connection distributor cap: M4, SAE

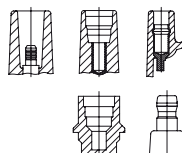

Connection distr. cap/ign. coil: 4 mm, Toyota 5 mm, DIN

Connection distr. cap/ign. coil: Ford, SAE

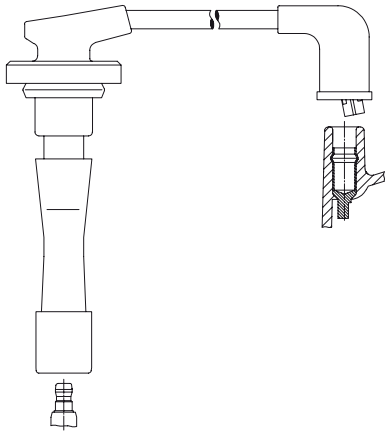

6A01/ 54  
Verwendung für: /  
applicable for:  
HONDA

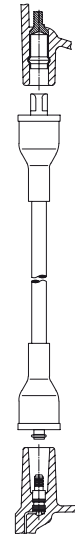

6A03/ 30  
Verwendung für: /  
applicable for:  
SAAB

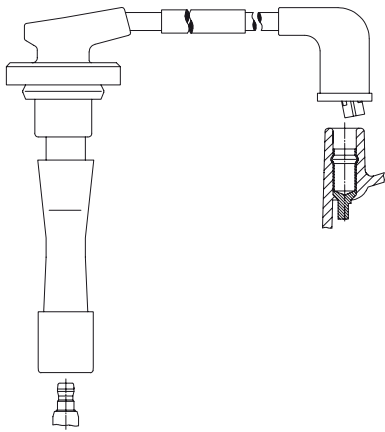

6A01E 31  
6A01E 45  
6A01E 65  
Verwendung für: /  
applicable for:  
HONDA

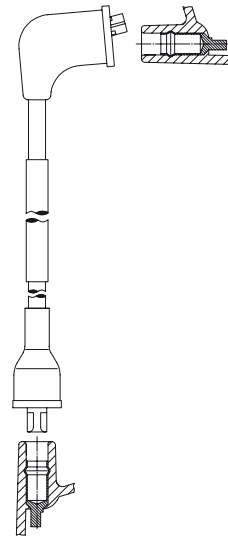

6A04E 43  
6A04E 48  
Verwendung für: /  
applicable for:  
HONDA

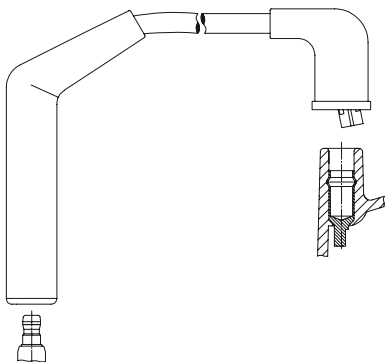

6A02/ 27  
6A02/ 31  
6A02/ 38  
6A02/ 41  
6A02/ 44  
6A02/ 48  
6A02/ 53  
6A02/ 56  
6A02/ 60  
6A02/ 64  
6A02/ 68  
6A02/ 71  
Verwendung für: /  
applicable for:  
HONDA

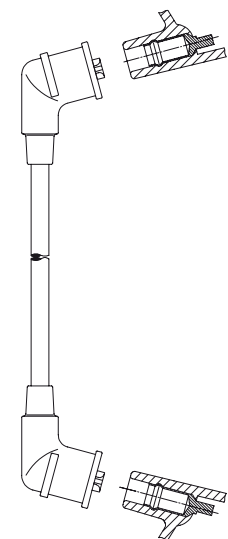

6A05/ 50  
Verwendung für: /  
applicable for:  
SUZUKI

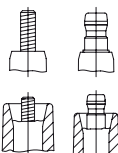

Connection spark plug: M4, SAE

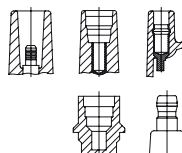

Connection distr. cap/ign. coil: 4 mm, Toyota 5 mm, DIN

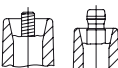

Connection distributor cap: M4, SAE



Connection distr. cap/ign. coil: Ford, SAE

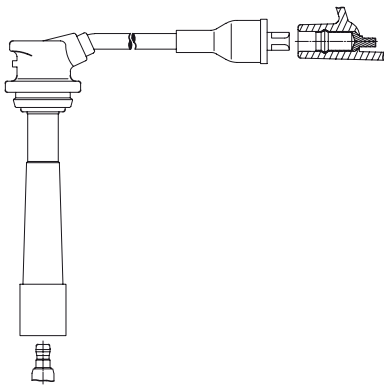

6A06/ 24  
 6A06/ 31  
 6A06/ 38  
 6A06/ 40  
 6A06/ 43  
 6A06/ 50  
 6A06/ 58  
 6A06/ 62  
 Verwendung für: /  
 applicable for:  
 SUZUKI

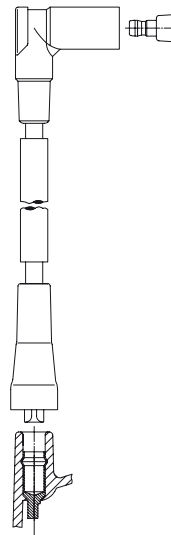

6A08E 56  
 Verwendung für: /  
 applicable for:  
 PEUGEOT

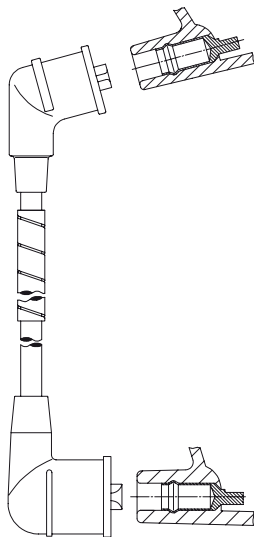

6A07E 30  
 6A07E 35  
 6A07E 62  
 6A07E 70  
 Verwendung für: /  
 applicable for:  
 FORD  
 NISSAN

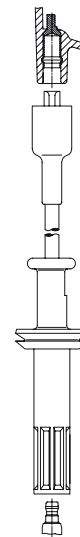

6A09/ 55  
 6A09/ 63  
 6A09/ 73  
 6A09/ 78  
 6A09/ 83  
 6A09/ 93  
 6A09/103  
 6A09/106  
 Verwendung für: /  
 applicable for:  
 ALFA ROMEO  
 LANCIA

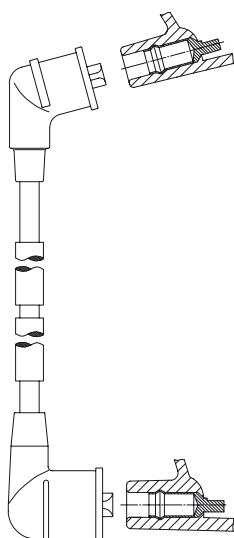

6A07F 20  
 Verwendung für: /  
 applicable for:  
 NISSAN

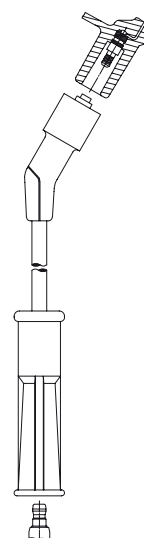

6A10/ 27  
 6A10/ 28  
 6A10/ 33  
 6A10/ 49  
 Verwendung für: /  
 applicable for:  
 RENAULT

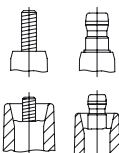

Connection spark plug: M4, SAE

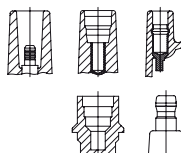

Connection distr. cap/ign. coil: 4 mm, Toyota 5 mm, DIN



Connection distributor cap: M4, SAE



Connection distr. cap/ign. coil: Ford, SAE

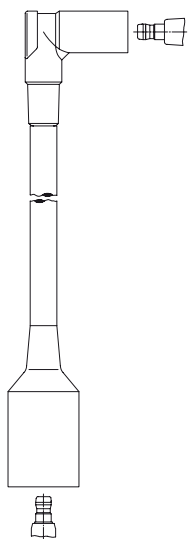

6A11E 43  
6A11E 52  
Verwendung für: /  
applicable for:  
CITROEN

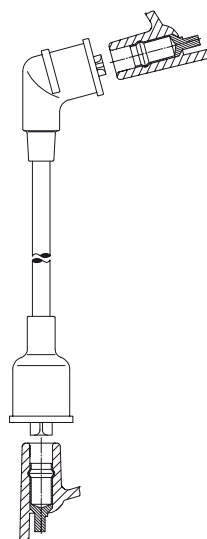

6A15/ 15  
6A15/ 89  
Verwendung für: /  
applicable for:  
HYUNDAI  
NISSAN  
TOYOTA

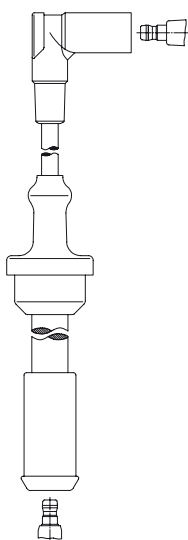

6A12/ 53  
6A12/ 93  
Verwendung für: /  
applicable for:  
CITROEN

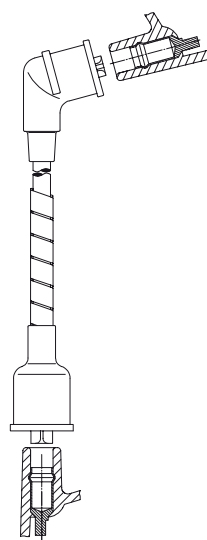

6A15E 46  
Verwendung für: /  
applicable for:  
DAIHATSU



6A13/ 75  
6A13/ 87  
Verwendung für: /  
applicable for:  
CITROEN

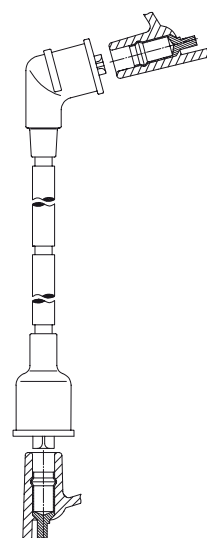

6A15F 23  
Verwendung für: /  
applicable for:  
NISSAN

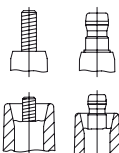

Connection spark plug: M4, SAE

Connection distributor cap: M4, SAE

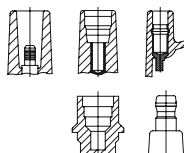

Connection distr. cap/ign. coil: 4 mm, Toyota 5 mm, DIN

Connection distr. cap/ign. coil: Ford, SAE



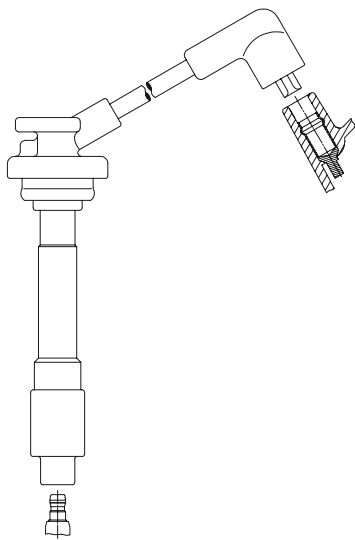

6A19/ 31  
6A19/ 40  
6A19/ 63  
Verwendung für: /  
applicable for:  
NISSAN

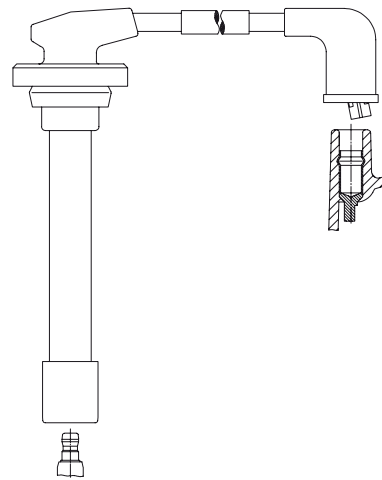

6A20E 55  
6A20E 63  
Verwendung für: /  
applicable for:  
HONDA

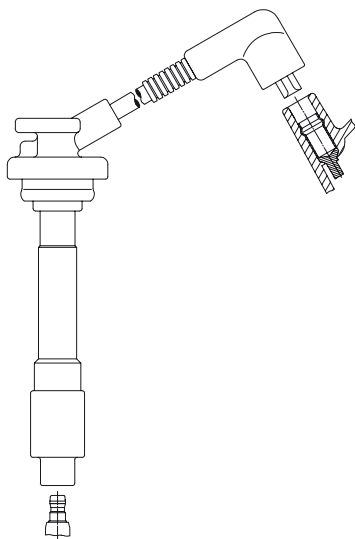

6A19E 56  
Verwendung für: /  
applicable for:  
NISSAN

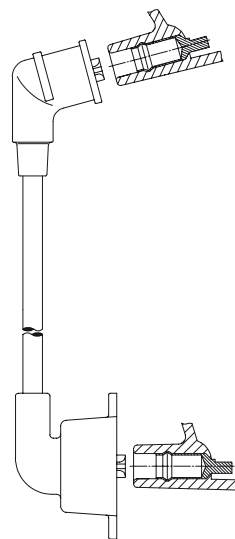

6A21/ 21  
Verwendung für: /  
applicable for:  
HONDA

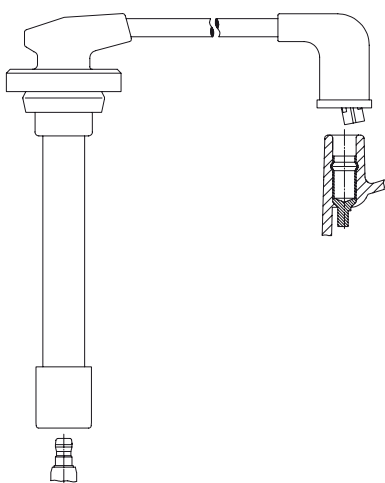

6A20 32  
6A20 40  
Verwendung für: /  
applicable for:  
HONDA

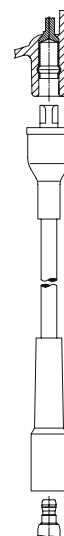

6A23/ 23  
6A23/ 37  
Verwendung für: /  
applicable for:  
TOYOTA

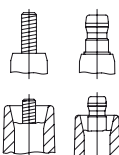

Connection spark plug: M4, SAE

Connection distributor cap: M4, SAE

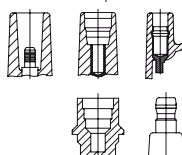

Connection distr. cap/ign. coil: 4 mm, Toyota 5 mm, DIN

Connection distr. cap/ign. coil: Ford, SAE

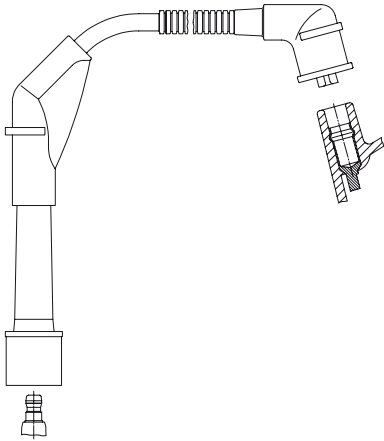

6A24E 26  
6A24E 37  
6A24E 52  
6A24E 71  
Verwendung für: /  
applicable for:  
NISSAN

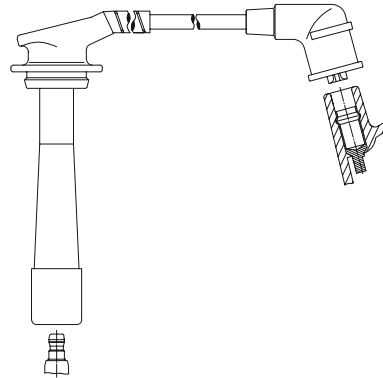

6A26E 29  
6A26E 40  
6A26E 43  
Verwendung für: /  
applicable for:  
DAIHATSU

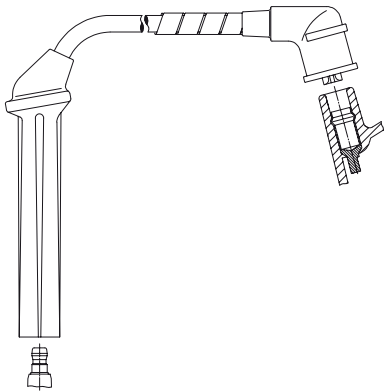

6A25E 61  
Verwendung für: /  
applicable for:  
NISSAN

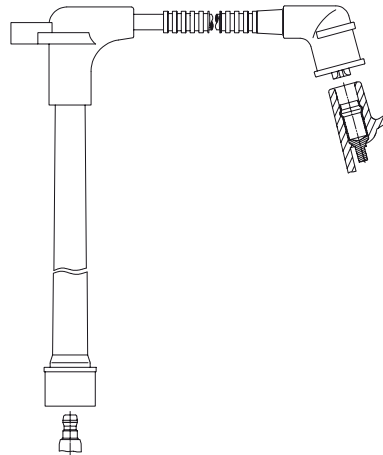

6A27E 37  
6A27E 42  
6A27E 54  
6A27E 55  
Verwendung für: /  
applicable for:  
NISSAN

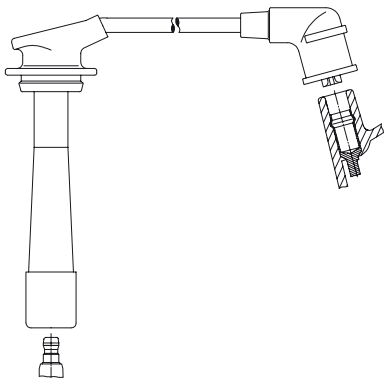

6A26/ 50  
6A26/ 25  
6A26/ 33  
6A26/ 43  
6A26/ 53  
6A26/ 62  
6A26/ 65  
Verwendung für: /  
applicable for:  
DAIHATSU



6A28/ 30  
6A28/ 35  
Verwendung für: /  
applicable for:  
MAZDA

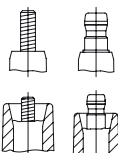

Connection spark plug: M4, SAE

Connection distributor cap: M4, SAE

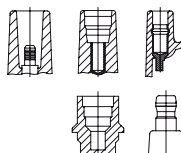

Connection distr. cap/ign. coil: 4 mm, Toyota 5 mm, DIN

Connection distr. cap/ign. coil: Ford, SAE

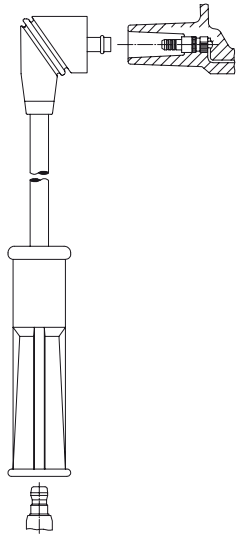

6A29/ 27  
 6A29/ 31  
 6A29/ 37  
 6A29/ 51  
 Verwendung für: /  
 applicable for:  
 DACIA  
 RENAULT



6A33E 36  
 6A33E 40  
 Verwendung für: /  
 applicable for:  
 MAZDA

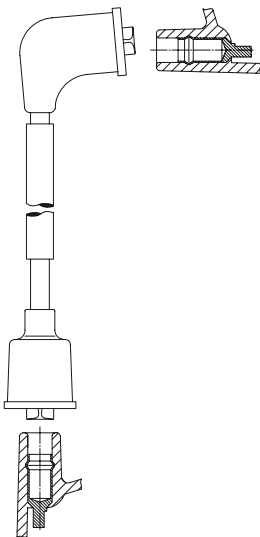

6A30E 32  
 6A30E 56  
 Verwendung für: /  
 applicable for:  
 MAZDA

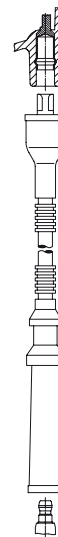

6A33F 52  
 Verwendung für: /  
 applicable for:  
 MAZDA

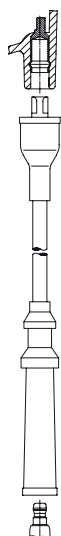

6A33/ 45  
 6A33/ 56  
 6A33/ 62  
 6A33/ 64  
 6A33/ 69  
 6A33/ 76  
 6A33/ 82  
 6A33/ 84  
 Verwendung für: /  
 applicable for:  
 MAZDA

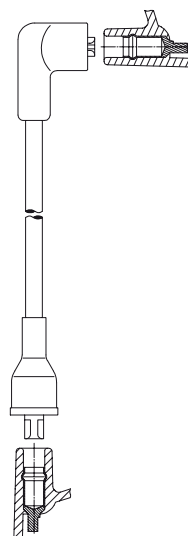

6A34/ 56  
 Verwendung für: /  
 applicable for:  
 CITROEN  
 PEUGEOT

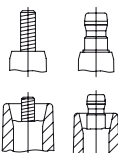

Connection spark plug: M4, SAE

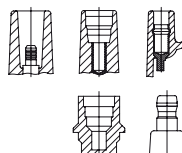

Connection distr. cap/ign. coil: 4 mm, Toyota 5 mm, DIN

Connection distributor cap: M4, SAE

Connection distr. cap/ign. coil: Ford, SAE

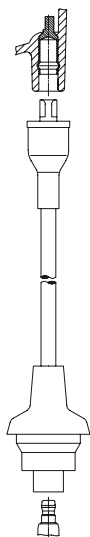

6A35/ 57  
 6A35/ 69  
 6A35/ 79  
 6A35/ 92  
 Verwendung für: /  
 applicable for:  
 CITROEN  
 PEUGEOT

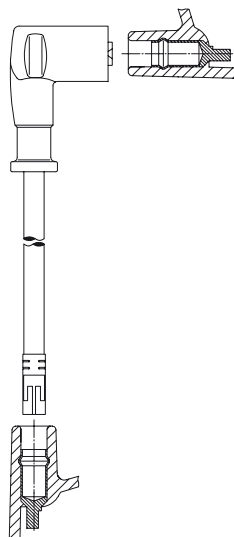

6A38/ 57  
 Verwendung für: /  
 applicable for:  
 ALFA ROMEO

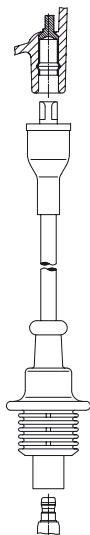

6A36/ 55  
 6A36/ 70  
 6A36/ 80  
 6A36/ 95  
 Verwendung für: /  
 applicable for:  
 PEUGEOT

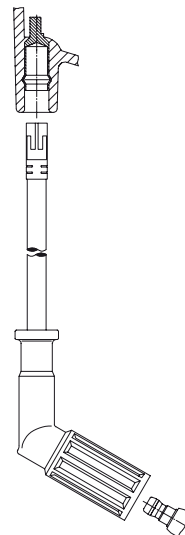

6A39/ 59  
 6A39/ 62  
 6A39/ 72  
 6A39/ 81  
 Verwendung für: /  
 applicable for:  
 ALFA ROMEO

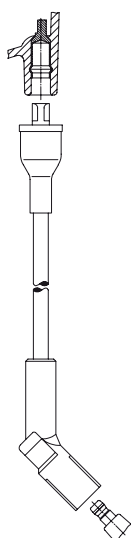

6A37/ 63  
 6A37/ 85  
 Verwendung für: /  
 applicable for:  
 PEUGEOT

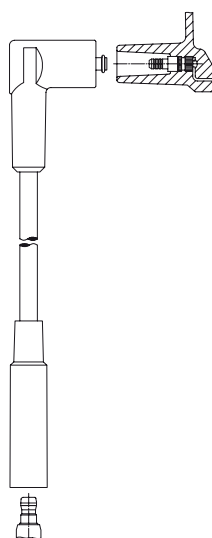

6A40/ 40  
 6A40/ 46  
 6A40/ 52  
 Verwendung für: /  
 applicable for:  
 SEAT

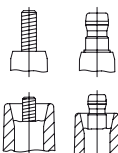

Connection spark plug: M4, SAE

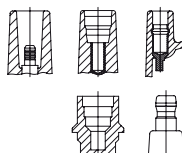

Connection distr. cap/ign. coil: 4 mm, Toyota 5 mm, DIN

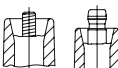

Connection distributor cap: M4, SAE



Connection distr. cap/ign. coil: Ford, SAE

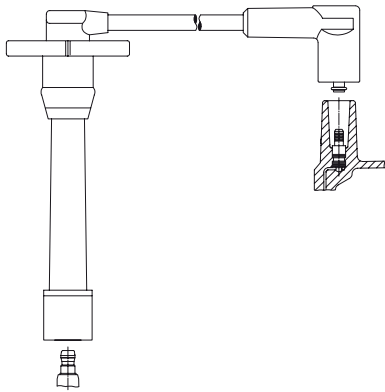

6A41/ 36  
6A41/ 39  
Verwendung für: /  
applicable for:  
TOYOTA

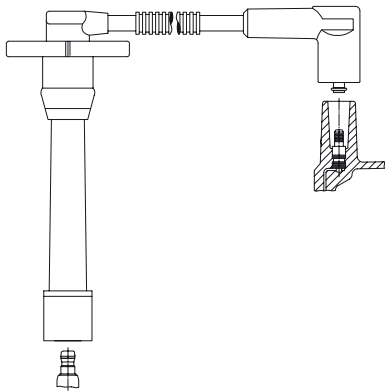

6A41E 48  
Verwendung für: /  
applicable for:  
TOYOTA

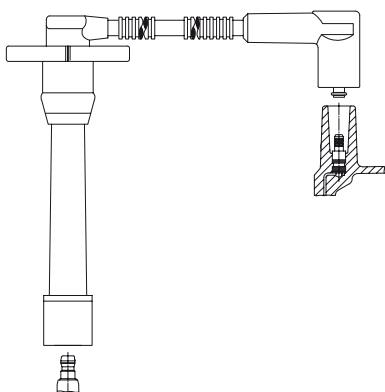

6A41F 55  
Verwendung für: /  
applicable for:  
TOYOTA

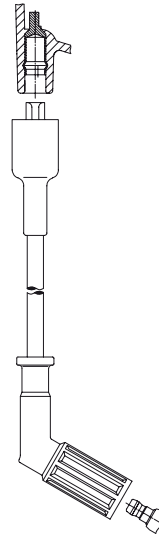

6A42/ 28  
6A42/ 30  
6A42/ 40  
Verwendung für: /  
applicable for:  
LANCIA

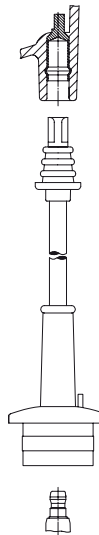

6A43/ 25  
6A43/ 30  
6A43/ 32  
6A43/ 40  
Verwendung für: /  
applicable for:  
TOYOTA

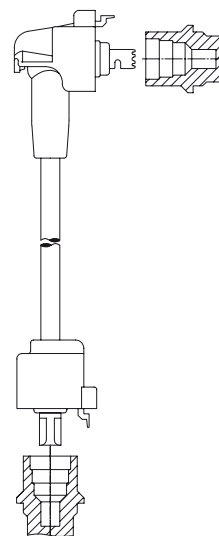

6A44/ 56  
Verwendung für: /  
applicable for:  
TOYOTA

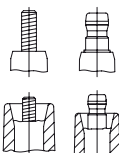

Connection spark plug: M4, SAE

Connection distributor cap: M4, SAE

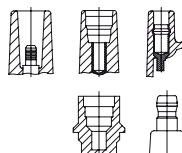

Connection distr. cap/ign. coil: 4 mm, Toyota 5 mm, DIN

Connection distr. cap/ign. coil: Ford, SAE

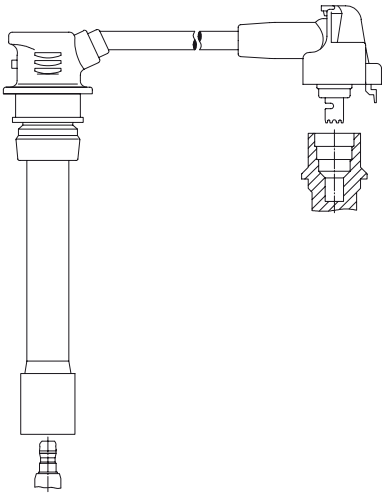

6A45/ 38  
 6A45/ 51  
 6A45/ 57  
 6A45/ 58  
 6A45/ 66  
 6A45/ 70  
 Verwendung für: /  
 applicable for:  
 TOYOTA

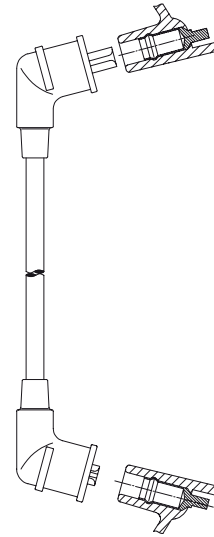

6A47/ 60  
 Verwendung für: /  
 applicable for:  
 TOYOTA

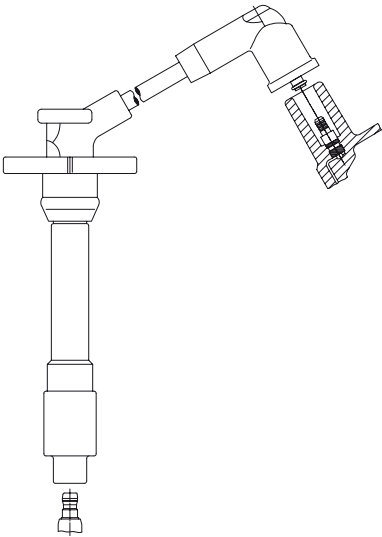

6A46/ 22  
 6A46/ 25  
 6A46/ 34  
 Verwendung für: /  
 applicable for:  
 TOYOTA

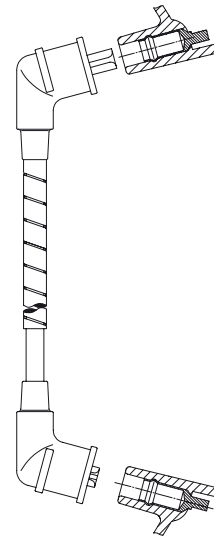

6A47E 29  
 Verwendung für: /  
 applicable for:  
 TOYOTA

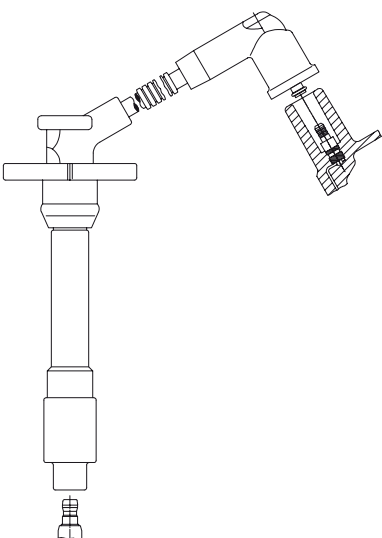

6A46E 66  
 Verwendung für: /  
 applicable for:  
 TOYOTA

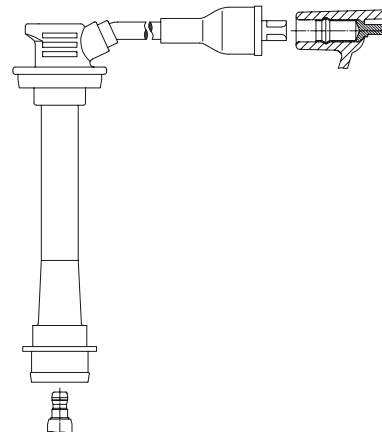

6A48/ 25  
 6A48/ 39  
 Verwendung für: /  
 applicable for:  
 TOYOTA

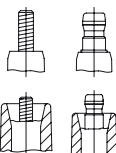

Connection spark plug: M4, SAE

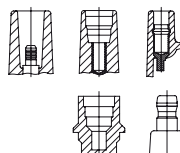

Connection distr. cap/ign. coil: 4 mm, Toyota 5 mm, DIN

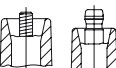

Connection distributor cap: M4, SAE



Connection distr. cap/ign. coil: Ford, SAE

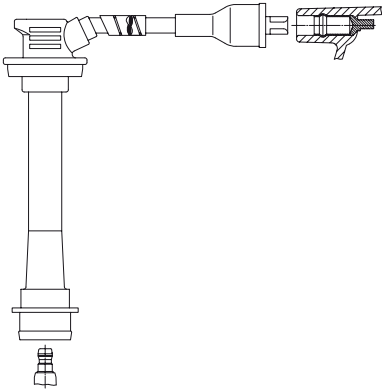

6A48E 44  
6A48E 58  
Verwendung für: /  
applicable for:  
TOYOTA

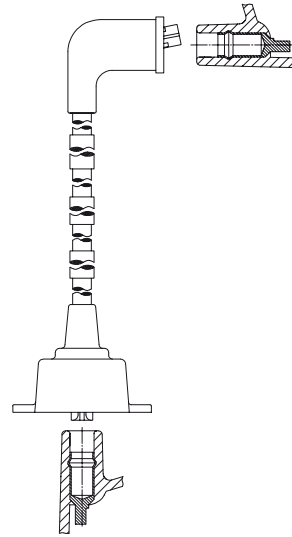

6A52H 58  
Verwendung für: /  
applicable for:  
HONDA

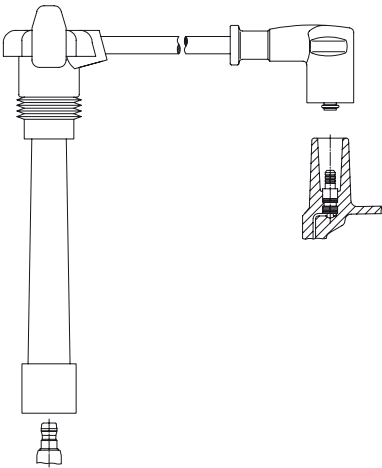

6A49/ 28  
6A49/ 32  
6A49/ 46  
6A49/ 60  
Verwendung für: /  
applicable for:  
FIAT  
LANCIA

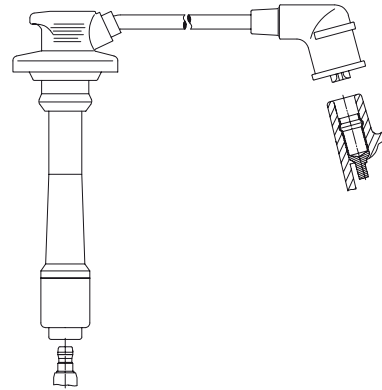

6A53/ 33  
6A53/ 37  
6A53/ 52  
6A53/ 55  
Verwendung für: /  
applicable for:  
TOYOTA

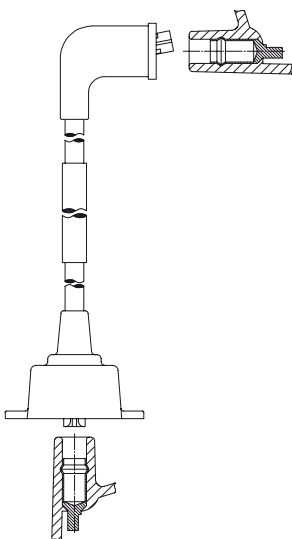

6A52E 44  
Verwendung für: /  
applicable for:  
HONDA

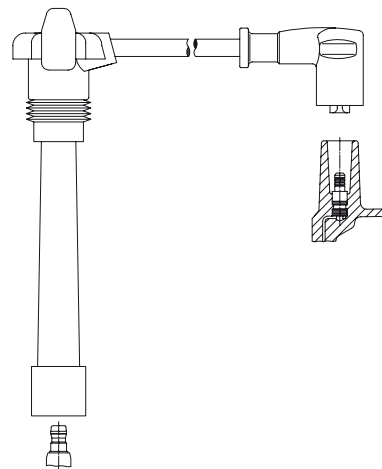

6A54/ 11  
6A54/ 19  
6A54/ 28  
6A54/ 40  
Verwendung für: /  
applicable for:  
FIAT

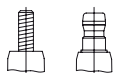

Connection spark plug: M4, SAE

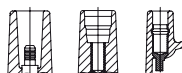

Connection distr. cap/ign. coil: 4 mm, Toyota 5 mm, DIN

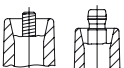

Connection distributor cap: M4, SAE



Connection distr. cap/ign. coil: Ford, SAE

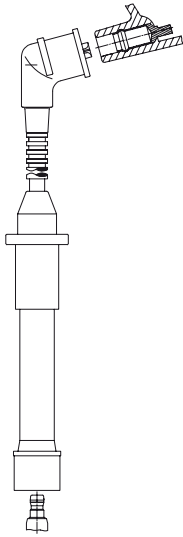

6A55E 43  
6A55E 56  
Verwendung für: /  
applicable for:  
NISSAN

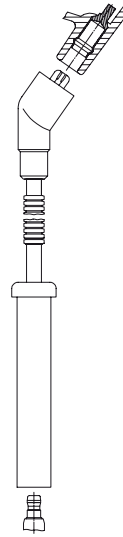

6A57E 42  
6A57E 46  
6A57E 61  
6A57E 65  
Verwendung für: /  
applicable for:  
MAZDA

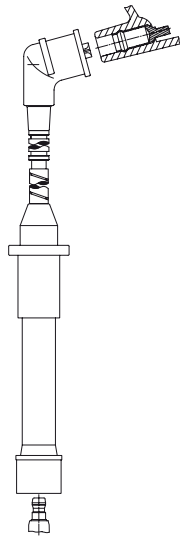

6A55F 73  
Verwendung für: /  
applicable for:  
NISSAN

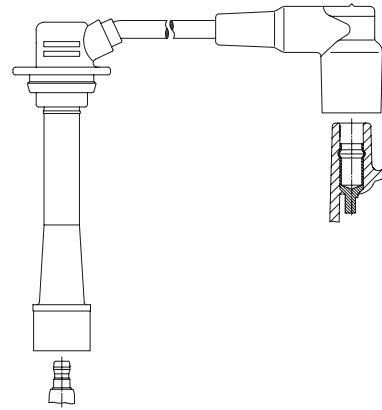

6A58/ 18  
6A58/ 28  
6A58/ 38  
Verwendung für: /  
applicable for:  
MAZDA

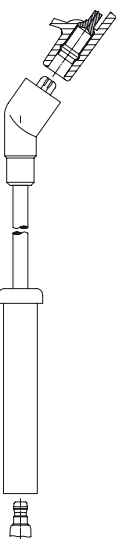

6A57/ 47  
Verwendung für: /  
applicable for:  
MAZDA

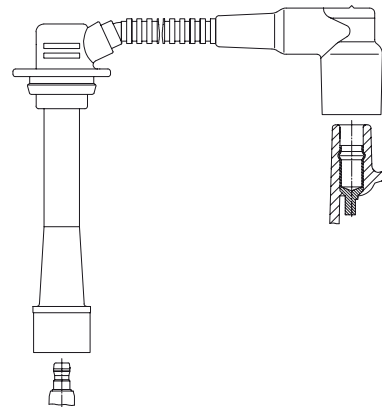

6A58E 14  
Verwendung für: /  
applicable for:  
MAZDA

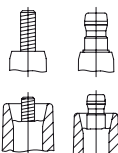

Connection spark plug: M4, SAE

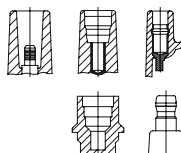

Connection distr. cap/ign. coil: 4 mm, Toyota 5 mm, DIN

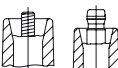

Connection distributor cap: M4, SAE



Connection distr. cap/ign. coil: Ford, SAE



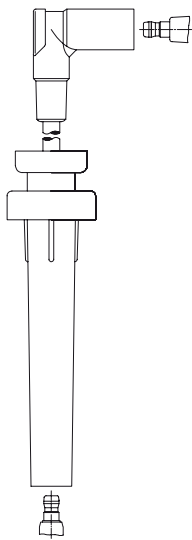

6A59/ 23  
6A59/ 30  
Verwendung für: /  
applicable for:  
CHRYSLER

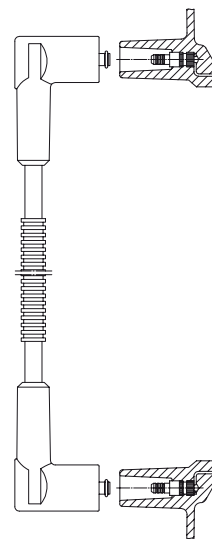

6A62E 56  
Verwendung für: /  
applicable for:  
TOYOTA

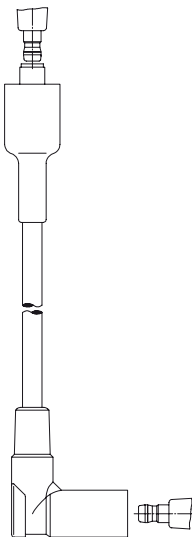

6A60/ 34  
Verwendung für: /  
applicable for:  
CHRYSLER

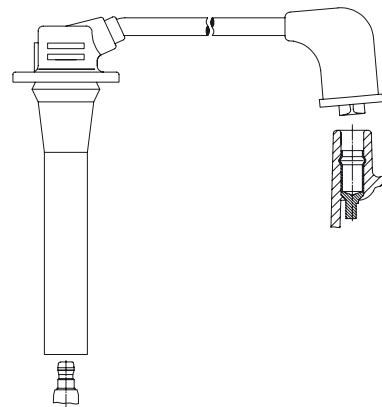

6A63/ 21  
6A63/ 23  
6A63/ 34  
Verwendung für: /  
applicable for:  
MAZDA

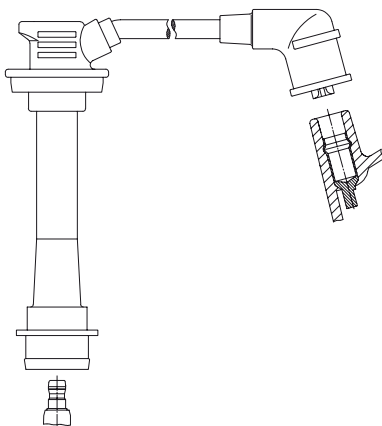

6A61/ 40  
6A61/ 50  
Verwendung für: /  
applicable for:  
TOYOTA

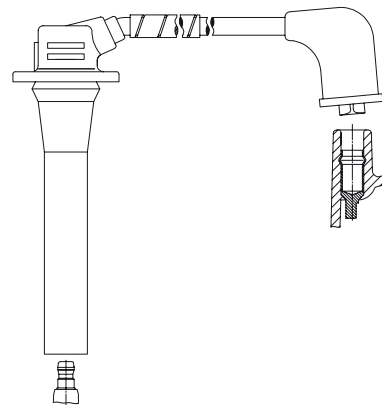

6A63E 45  
Verwendung für: /  
applicable for:  
MAZDA

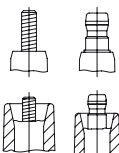

Connection spark plug: M4, SAE

Connection distributor cap: M4, SAE

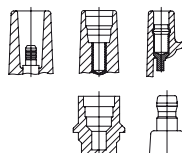

Connection distr. cap/ign. coil: 4 mm, Toyota 5 mm, DIN

Connection distr. cap/ign. coil: Ford, SAE

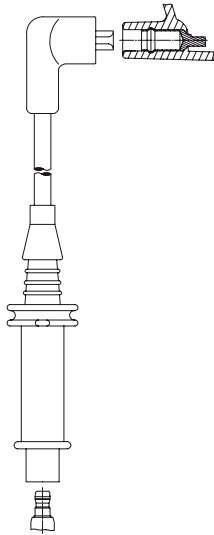

6A64/ 50  
6A64/ 52  
6A64/ 65  
6A64/ 70  
Verwendung für: /  
applicable for:  
CITROEN

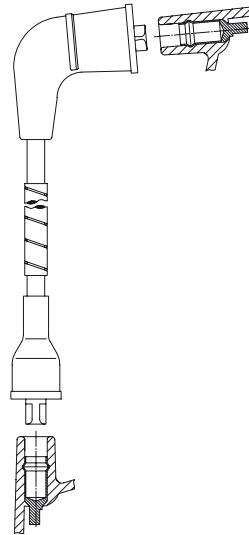

6A67E 40  
Verwendung für: /  
applicable for:  
SUZUKI

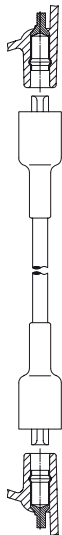

6A65/ 38  
Verwendung für: /  
applicable for:  
FIAT  
LANCIA

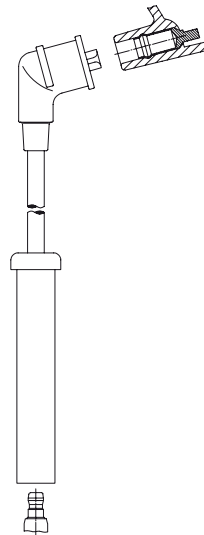

6A68/ 63  
6A68/ 68  
Verwendung für: /  
applicable for:  
MAZDA

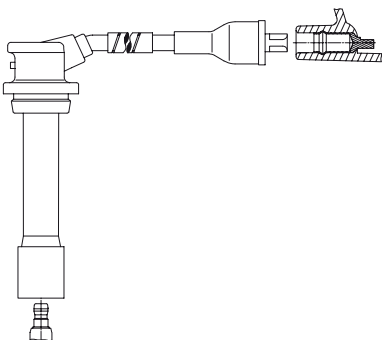

6A66E 36  
6A66E 40  
6A66E 52  
6A66E 58  
Verwendung für: /  
applicable for:  
SUZUKI

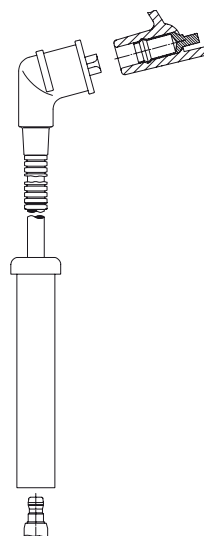

6A68E 50  
Verwendung für: /  
applicable for:  
MAZDA

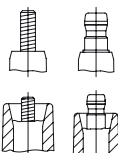

Connection spark plug: M4, SAE

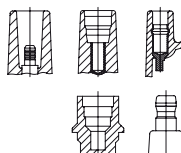

Connection distr. cap/ign. coil: 4 mm, Toyota 5 mm, DIN

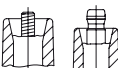

Connection distributor cap: M4, SAE



Connection distr. cap/ign. coil: Ford, SAE

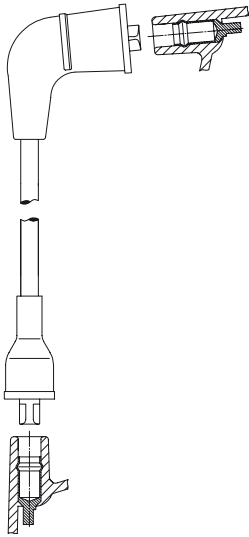

6A69/ 44  
Verwendung für: /  
applicable for:  
DAIHATSU

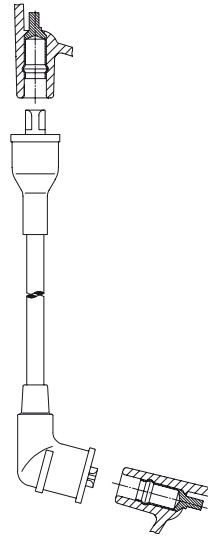

6A72/ 40  
Verwendung für: /  
applicable for:  
TOYOTA

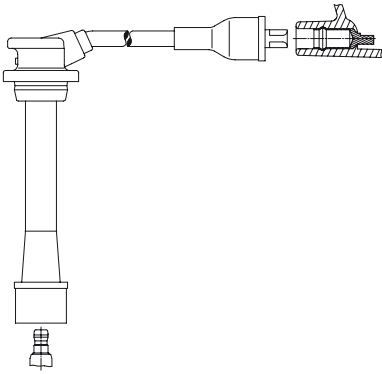

6A70/ 25  
6A70/ 9  
Verwendung für: /  
applicable for:  
SUBARU  
SUZUKI

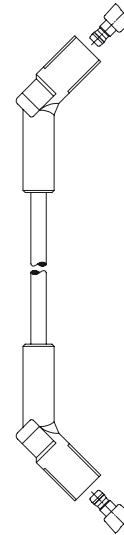

6A74/ 52  
Verwendung für: /  
applicable for:  
FIAT  
PEUGEOT

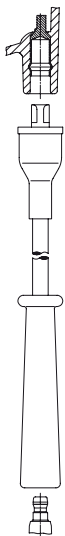

6A71/ 34  
6A71/ 38  
Verwendung für: /  
applicable for:  
DAIHATSU  
TOYOTA

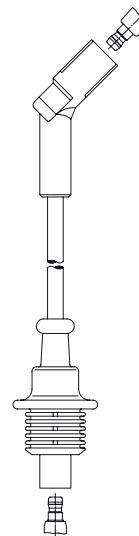

6A75/ 53  
6A75/ 60  
6A75/ 71  
6A75/ 90  
Verwendung für: /  
applicable for:  
FIAT  
PEUGEOT

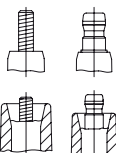

Connection spark plug: M4, SAE

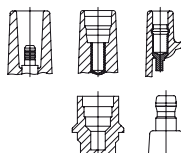

Connection distr. cap/ign. coil: 4 mm, Toyota 5 mm, DIN

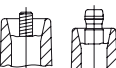

Connection distributor cap: M4, SAE



Connection distr. cap/ign. coil: Ford, SAE

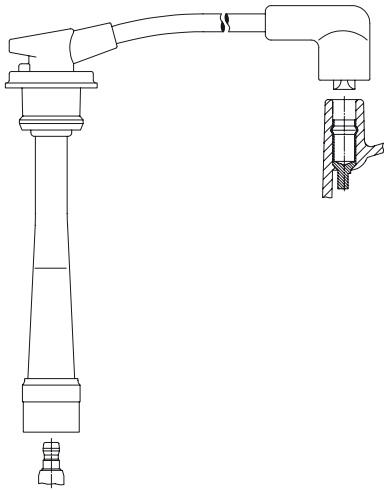

6A76/ 23  
 6A76/ 32  
 6A76/ 40  
 6A76/ 54  
 Verwendung für: /  
 applicable for:  
 HYUNDAI

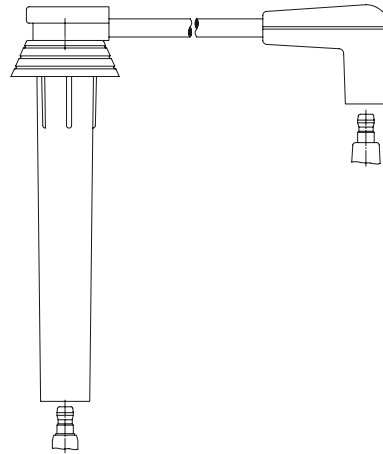

6A80/ 14  
 6A80/ 18  
 6A80/ 24  
 6A80/ 26  
 Verwendung für: /  
 applicable for:  
 MINI

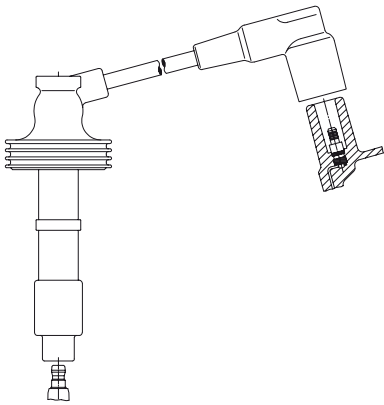

6A77/ 35  
 6A77/ 42  
 6A77/ 62  
 Verwendung für: /  
 applicable for:  
 VOLVO

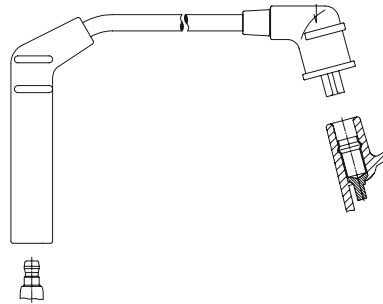

6A81/ 27  
 6A81/ 32  
 6A81/ 40  
 6A81/ 52  
 Verwendung für: /  
 applicable for:  
 HYUNDAI

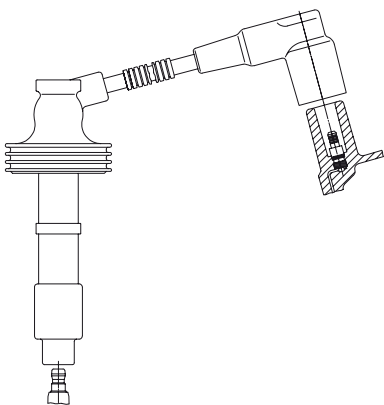

6A77E 24  
 6A77E 56  
 Verwendung für: /  
 applicable for:  
 VOLVO

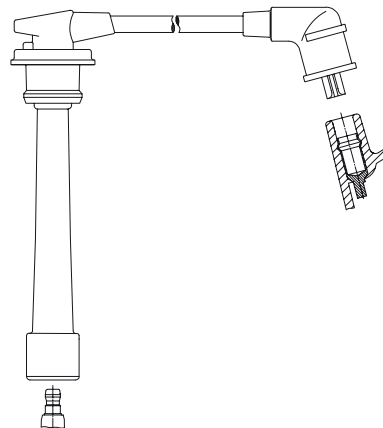

6A82/ 21  
 6A82/ 24  
 6A82/ 30  
 6A82/ 33  
 6A82/ 39  
 6A82/ 41  
 6A82/ 53  
 Verwendung für: /  
 applicable for:  
 HYUNDAI  
 KIA

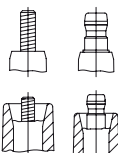

Connection spark plug: M4, SAE

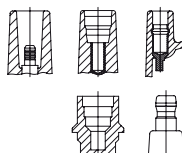

Connection distr. cap/ign. coil: 4 mm, Toyota 5 mm, DIN

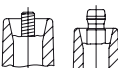

Connection distributor cap: M4, SAE



Connection distr. cap/ign. coil: Ford, SAE

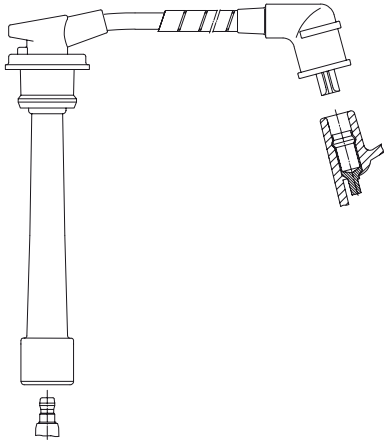

6A82E 51  
Verwendung für: /  
applicable for:  
HYUNDAI

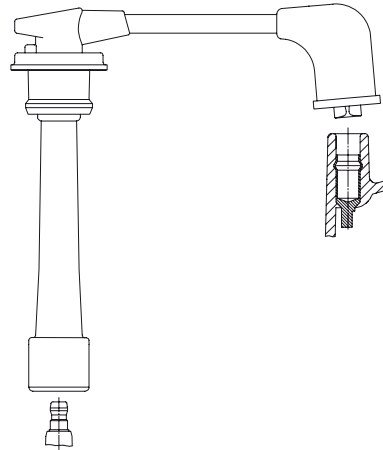

6A85/ 22  
6A85/ 31  
6A85/ 40  
6A85/ 45  
Verwendung für: /  
applicable for:  
HYUNDAI

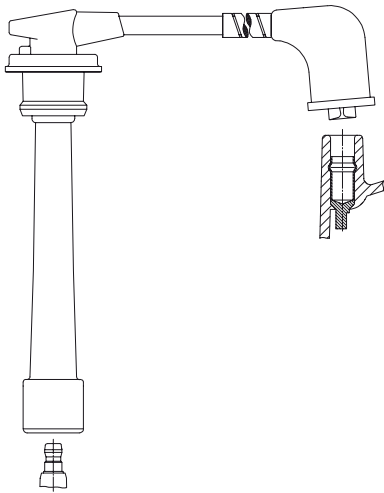

6A83E 37  
Verwendung für: /  
applicable for:  
HYUNDAI

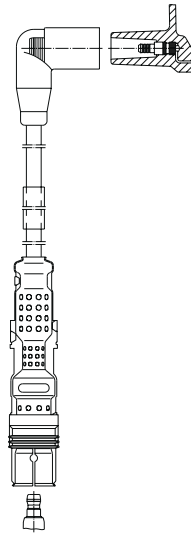

6A98E 42  
6A98E 54  
6A98E 57  
6A98E 60  
Verwendung für: /  
applicable for:  
AUDI  
SEAT  
SKODA  
VW

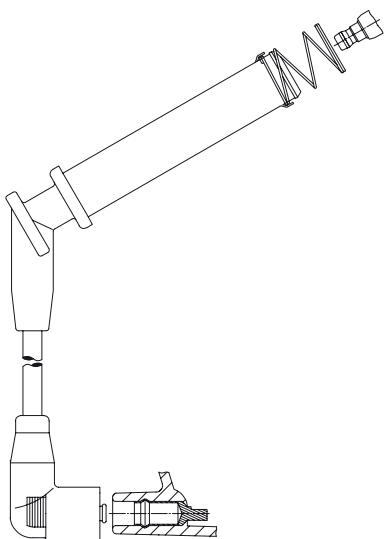

6A84/ 20  
6A84/ 33  
6A84/ 37  
6A84/ 42  
Verwendung für: /  
applicable for:  
FORD



601/ 55  
601/ 65  
601/ 75  
601/ 80  
Verwendung für: /  
applicable for:  
CITROEN  
PEUGEOT  
RENAULT

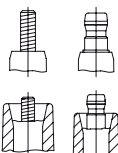

Connection spark plug: M4, SAE

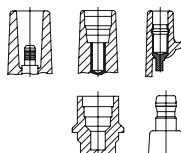

Connection distr. cap/ign. coil: 4 mm, Toyota 5 mm, DIN

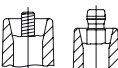

Connection distributor cap: M4, SAE



Connection distr. cap/ign. coil: Ford, SAE

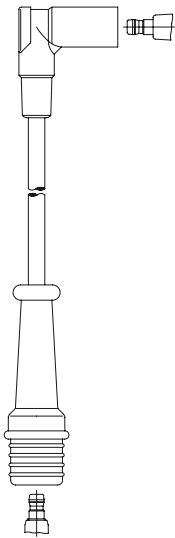

602/ 30  
602/ 40  
602/ 60  
602/ 65  
Verwendung für: /  
applicable for:  
PEUGEOT  
RENAULT

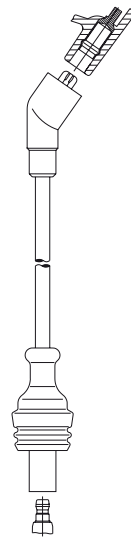

606/ 35  
606/ 45  
606/ 50  
Verwendung für: /  
applicable for:  
PEUGEOT

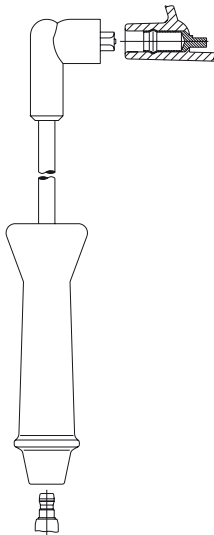

603/ 70  
603/ 85  
603/ 90  
603/100  
Verwendung für: /  
applicable for:  
PEUGEOT

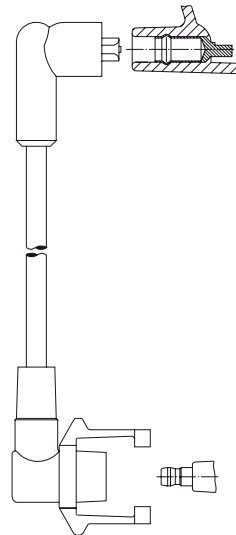

607/ 38  
607/ 45  
607/ 55  
607/ 60  
607/ 65  
607/ 70  
Verwendung für: /  
applicable for:  
RENAULT  
VOLVO



605/ 60  
Verwendung für: /  
applicable for:  
CITROEN

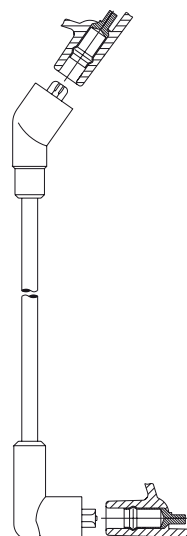

608/ 75  
Verwendung für: /  
applicable for:  
PEUGEOT

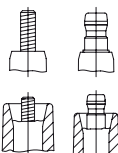

Connection spark plug: M4, SAE

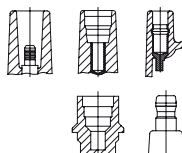

Connection distr. cap/ign. coil: 4 mm, Toyota 5 mm, DIN

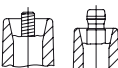

Connection distributor cap: M4, SAE



Connection distr. cap/ign. coil: Ford, SAE

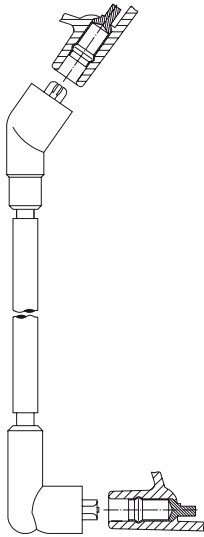

608E 43  
Verwendung für: /  
applicable for:  
SAAB

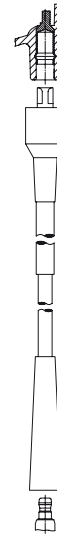

610E 35  
Verwendung für: /  
applicable for:  
RENAULT  
VOLVO

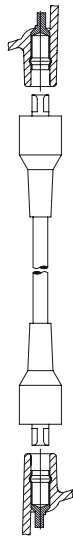

609/ 35  
Verwendung für: /  
applicable for:  
SUZUKI

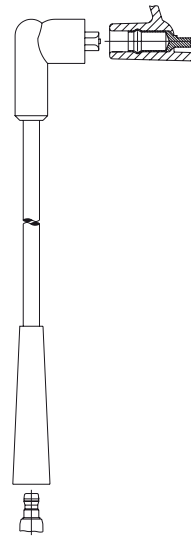

611/ 60  
611/ 65  
611/ 75  
611/ 85  
Verwendung für: /  
applicable for:  
CITROEN  
PEUGEOT  
RENAULT

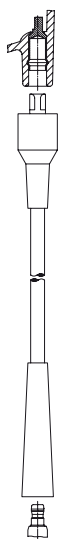

610/ 35  
610/ 40  
610/ 45  
610/ 48  
610/ 56  
610/ 60  
Verwendung für: /  
applicable for:  
RENAULT  
SEAT  
SUZUKI  
VOLVO

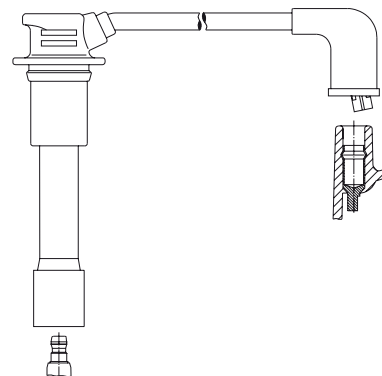

612/ 30  
612/ 35  
612/ 40  
612/ 50  
612/ 55  
612/ 60  
Verwendung für: /  
applicable for:  
MAZDA

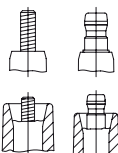

Connection spark plug: M4, SAE

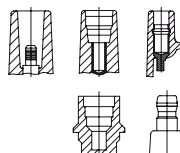

Connection distr. cap/ign. coil: 4 mm, Toyota 5 mm, DIN

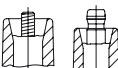

Connection distributor cap: M4, SAE



Connection distr. cap/ign. coil: Ford, SAE

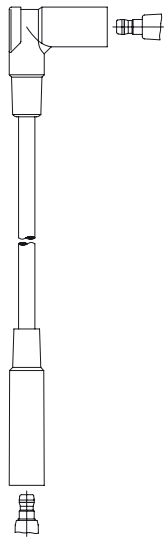

613/ 30  
613/ 70  
613/ 85  
Verwendung für: /  
applicable for:  
CITROEN  
PEUGEOT

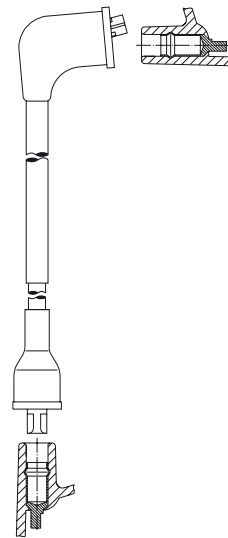

615E 43  
615E 53  
615E 56  
Verwendung für: /  
applicable for:  
FORD  
MAZDA

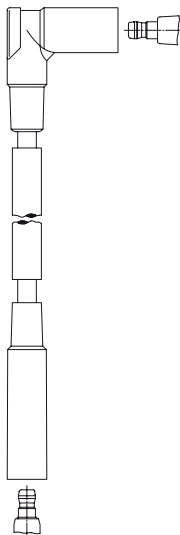

613E 27  
Verwendung für: /  
applicable for:  
CITROEN  
PEUGEOT

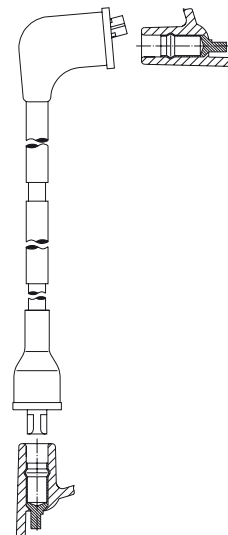

615F 60  
Verwendung für: /  
applicable for:  
MAZDA

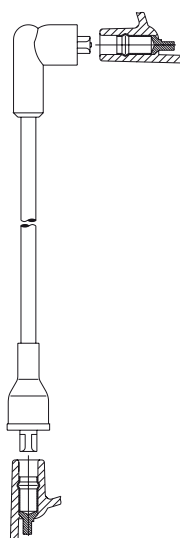

614/ 37  
614/ 45  
614/ 50  
614/ 55  
614/ 60  
614/ 80  
614/ 90  
Verwendung für: /  
applicable for:  
CITROEN  
PEUGEOT  
RENAULT  
SEAT

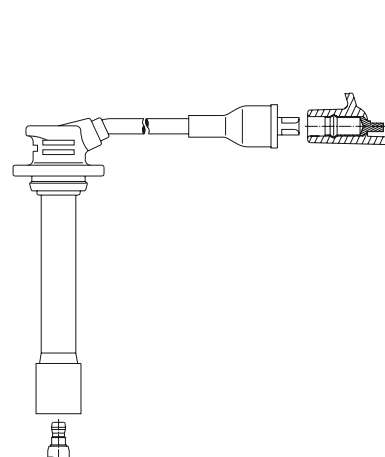

616/ 45  
616/ 60  
Verwendung für: /  
applicable for:  
MAZDA

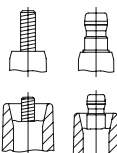

Connection spark plug: M4, SAE

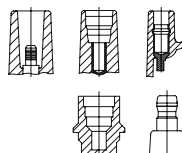

Connection distr. cap/ign. coil: 4 mm, Toyota 5 mm, DIN

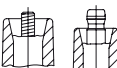

Connection distributor cap: M4, SAE



Connection distr. cap/ign. coil: Ford, SAE



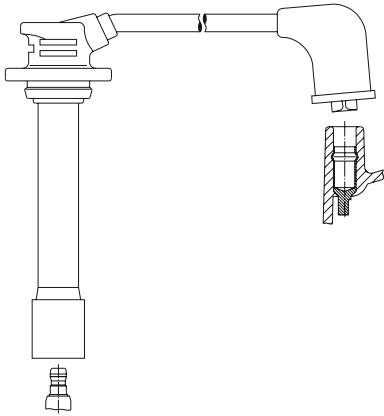

617/ 45  
617/ 60  
Verwendung für: /  
applicable for:  
MAZDA

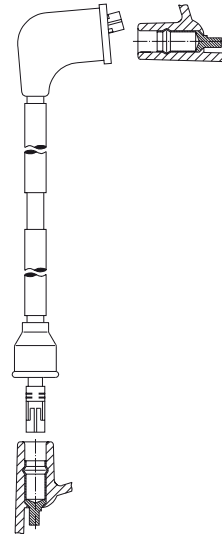

619F 50  
Verwendung für: /  
applicable for:  
MAZDA

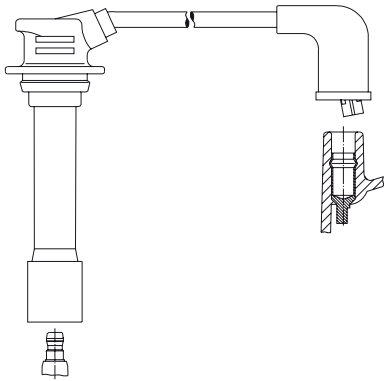

618/ 35  
618/ 45  
618/ 50  
618/ 65  
Verwendung für: /  
applicable for:  
MAZDA



620/ 25  
Verwendung für: /  
applicable for:  
PEUGEOT

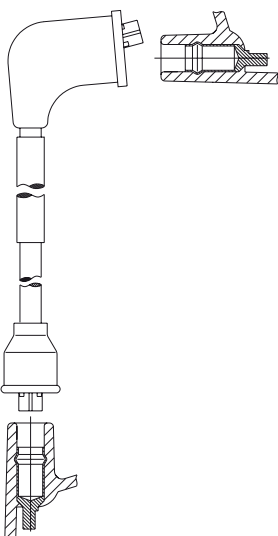

619E 25  
619E 55  
Verwendung für: /  
applicable for:  
MAZDA

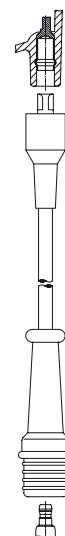

622/ 35  
622/ 40  
622/ 50  
622/ 60  
622/ 65  
622/115  
622/140  
Verwendung für: /  
applicable for:  
CITROEN  
PEUGEOT  
RENAULT

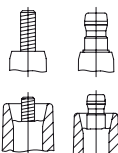

Connection spark plug: M4, SAE

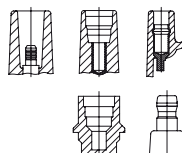

Connection distr. cap/ign. coil: 4 mm, Toyota 5 mm, DIN

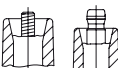

Connection distributor cap: M4, SAE



Connection distr. cap/ign. coil: Ford, SAE

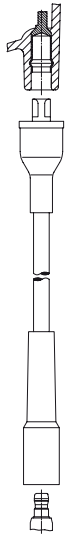

623/ 35  
 623/ 40  
 623/ 45  
 623/ 55  
 623/ 65  
 623/ 75  
 623/ 85  
 623/ 90  
 623/100  
 Verwendung für: /  
 applicable for:  
 PEUGEOT  
 RENAULT

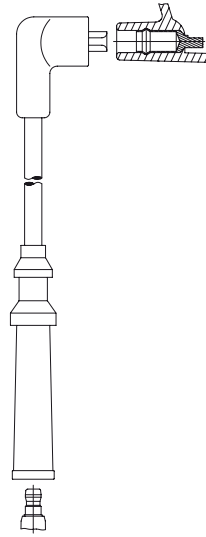

626/ 44  
 626/ 49  
 626/ 69  
 626/ 73  
 Verwendung für: /  
 applicable for:  
 SAAB

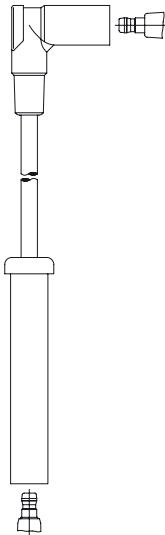

624/ 48  
 624/ 60  
 624/ 68  
 Verwendung für: /  
 applicable for:  
 CITROEN

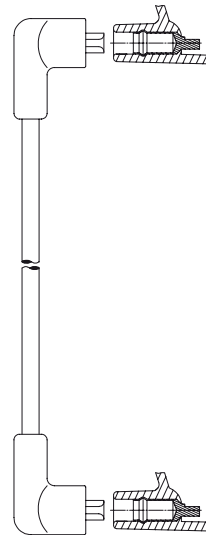

627/ 40  
 627/ 50  
 627/ 60  
 627/ 70  
 627/ 90  
 Verwendung für: /  
 applicable for:  
 AUSTIN  
 CITROEN  
 FIAT  
 MITSUBISHI  
 PEUGEOT  
 RENAULT  
 SEAT  
 VOLVO

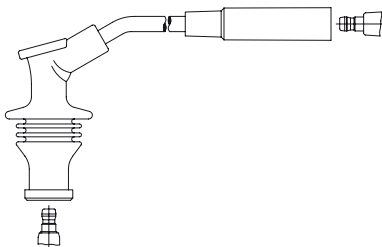

625/ 25  
 625/ 35  
 625/ 40  
 625/ 50  
 Verwendung für: /  
 applicable for:  
 RENAULT

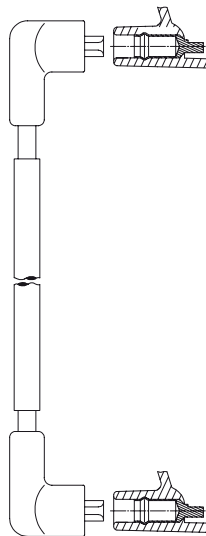

627E 26  
 627E 27  
 627E 40  
 Verwendung für: /  
 applicable for:  
 SAAB

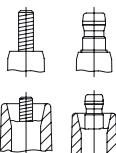

Connection spark plug: M4, SAE

Connection distributor cap: M4, SAE

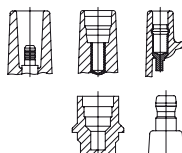

Connection distr. cap/ign. coil: 4 mm, Toyota 5 mm, DIN

Connection distr. cap/ign. coil: Ford, SAE

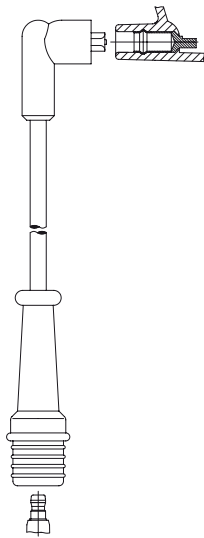

630/ 30  
 630/ 35  
 630/ 38  
 630/ 40  
 630/ 45  
 630/ 55  
 630/ 60  
 630/ 65  
 Verwendung für: /  
 applicable for:  
 RENAULT

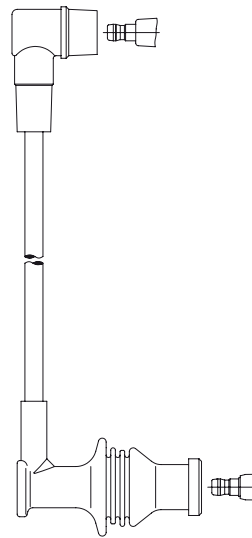

633/ 25  
 633/ 40  
 633/ 45  
 633/ 55  
 Verwendung für: /  
 applicable for:  
 RENAULT

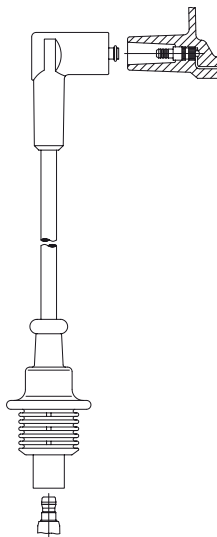

631/ 35  
 631/ 40  
 631/ 50  
 631/ 52  
 631/ 60  
 631/ 62  
 631/ 70  
 631/ 72  
 Verwendung für: /  
 applicable for:  
 CITROEN  
 FIAT  
 PEUGEOT

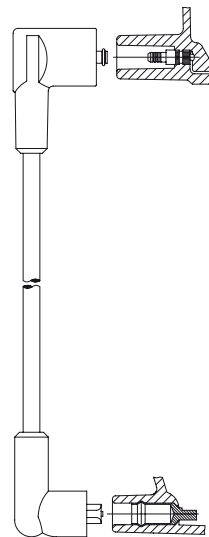

634/ 40  
 Verwendung für: /  
 applicable for:  
 CITROEN  
 PEUGEOT

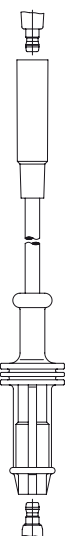

632/ 45  
 632/ 52  
 632/ 55  
 632/ 60  
 632/ 62  
 632/ 67  
 632/ 70  
 632/ 77  
 Verwendung für: /  
 applicable for:  
 CITROEN  
 PEUGEOT

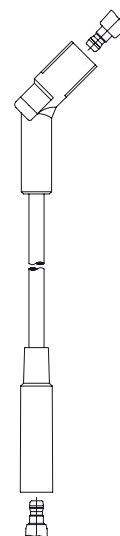

637/ 65  
 Verwendung für: /  
 applicable for:  
 CITROEN  
 PEUGEOT

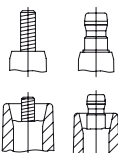

Connection spark plug: M4, SAE

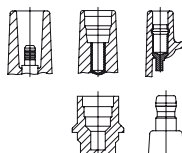

Connection distr. cap/ign. coil: 4 mm, Toyota 5 mm, DIN

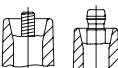

Connection distributor cap: M4, SAE



Connection distr. cap/ign. coil: Ford, SAE

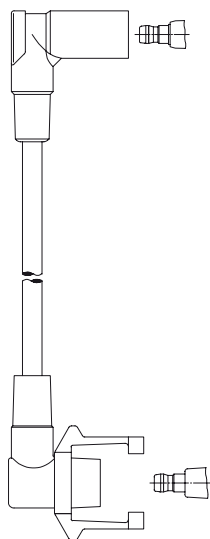

638/ 25  
638/ 30  
638/ 38  
638/ 90  
Verwendung für: /  
applicable for:  
RENAULT  
VOLVO

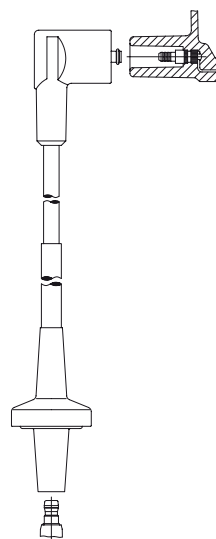

641E110  
Verwendung für: /  
applicable for:  
RENAULT

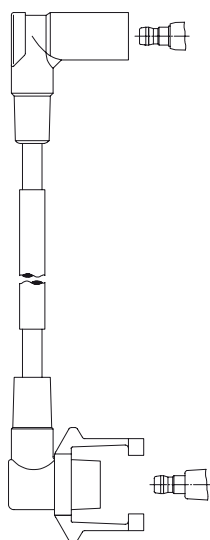

638E 70  
Verwendung für: /  
applicable for:  
PEUGEOT  
RENAULT

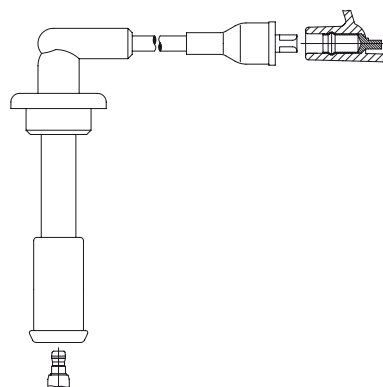

642/ 35  
642/ 55  
642/ 65  
642/ 80  
Verwendung für: /  
applicable for:  
PEUGEOT

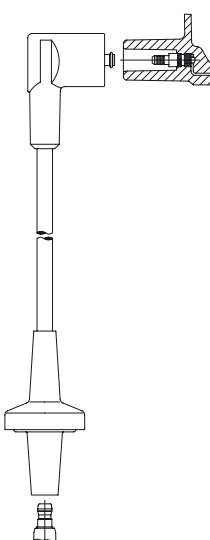

641/ 40  
641/ 55  
641/ 70  
641/ 85  
Verwendung für: /  
applicable for:  
RENAULT

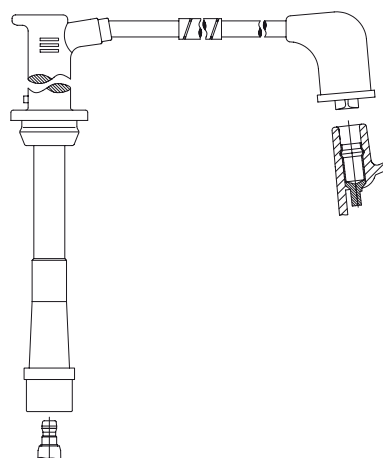

642E 59  
Verwendung für: /  
applicable for:  
MAZDA

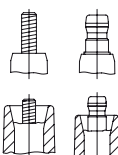

Connection spark plug: M4, SAE

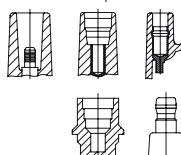

Connection distr. cap/ign. coil: 4 mm, Toyota 5 mm, DIN

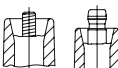

Connection distributor cap: M4, SAE



Connection distr. cap/ign. coil: Ford, SAE

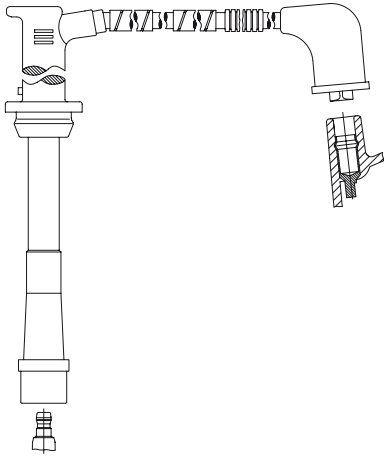

642H 92  
Verwendung für: /  
applicable for:  
MAZDA

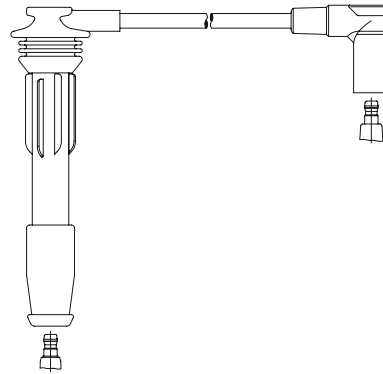

645/ 30  
645/ 40  
Verwendung für: /  
applicable for:  
RENAULT

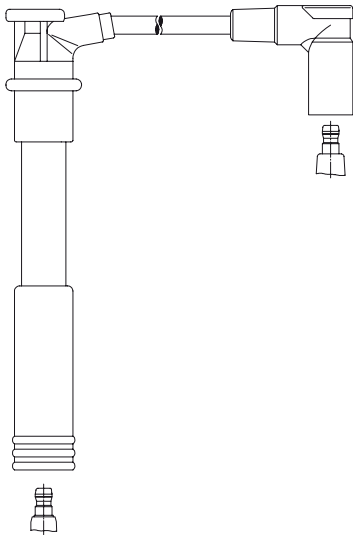

643/ 55  
Verwendung für: /  
applicable for:  
RENAULT

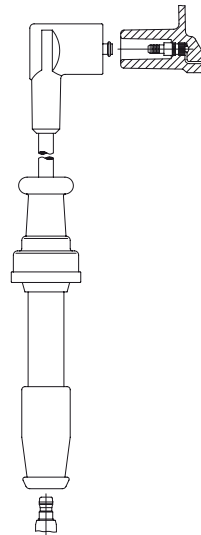

648/ 45  
648/ 60  
648/ 65  
648/ 90  
648/100  
648/105  
Verwendung für: /  
applicable for:  
CITROEN  
PEUGEOT

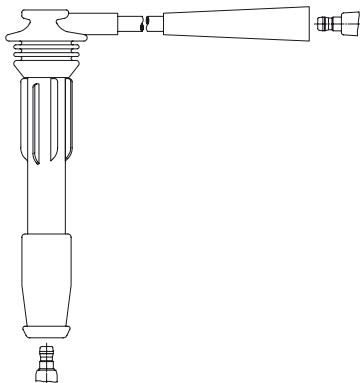

644/ 55  
644/ 60  
Verwendung für: /  
applicable for:  
RENAULT

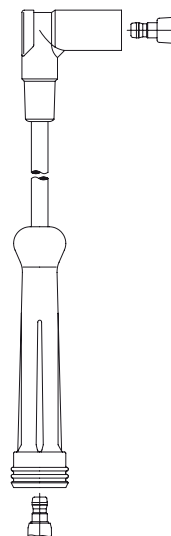

649/ 35  
649/ 40  
649/ 65  
649/ 70  
Verwendung für: /  
applicable for:  
RENAULT

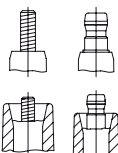

Connection spark plug: M4, SAE

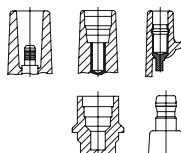

Connection distributor cap: M4, SAE

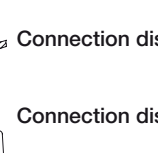

Connection distr. cap/ign. coil: 4 mm, Toyota 5 mm, DIN



Connection distr. cap/ign. coil: Ford, SAE

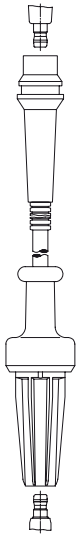

650E 72  
650E 75  
650E 88  
Verwendung für: /  
applicable for:  
RENAULT

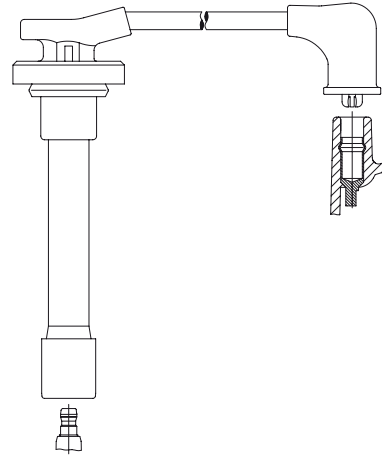

655/ 36  
655/ 40  
655/ 41  
655/ 45  
655/ 48  
655/ 56  
655/ 60  
655/ 62  
655/ 65  
Verwendung für: /  
applicable for:  
HONDA  
ROVER

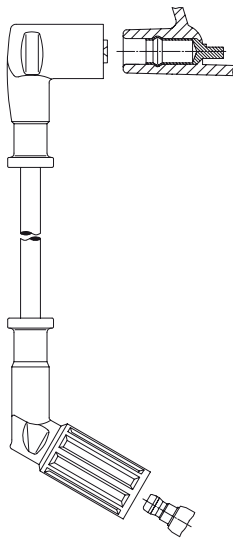

652/ 27  
652/ 34  
652/ 37  
652/ 44  
652/ 51  
Verwendung für: /  
applicable for:  
ALFA ROMEO  
FIAT  
LANCIA

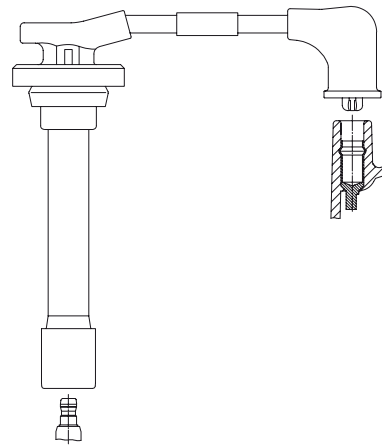

655E 67  
Verwendung für: /  
applicable for:  
HONDA

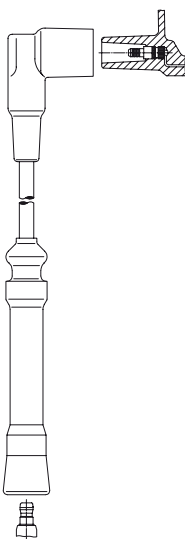

654/ 30  
654/ 35  
654/ 40  
654/ 50  
654/ 60  
Verwendung für: /  
applicable for:  
VOLVO

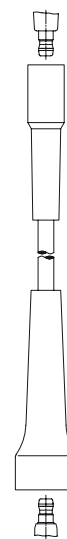

656/ 31  
656/ 35  
656/ 40  
656/ 45  
656/ 60  
Verwendung für: /  
applicable for:  
RENAULT

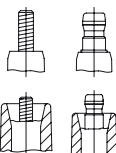

Connection spark plug: M4, SAE

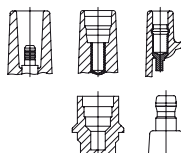

Connection distr. cap/ign. coil: 4 mm, Toyota 5 mm, DIN



Connection distributor cap: M4, SAE



Connection distr. cap/ign. coil: Ford, SAE

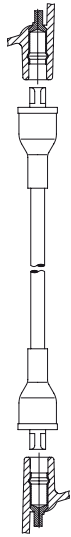

657/ 50  
657/ 57  
657/ 75  
657/ 80  
Verwendung für: /  
applicable for:  
OPEL  
PEUGEOT  
RENAULT  
SEAT  
TOYOTA

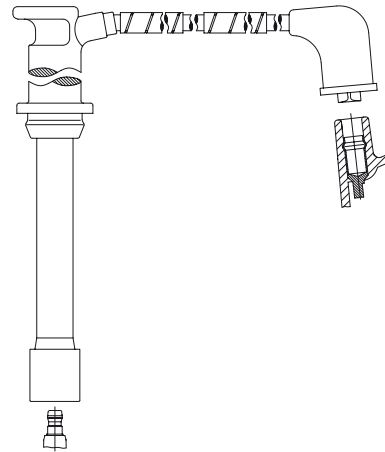

658F 63  
658F 86  
658F104  
Verwendung für: /  
applicable for:  
MAZDA

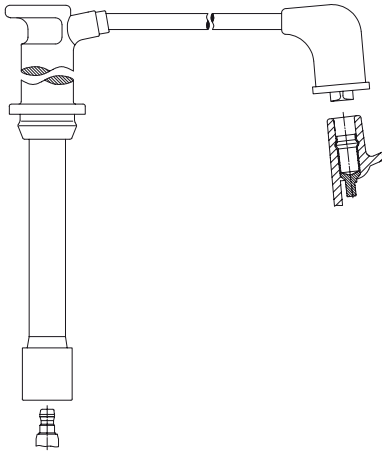

658/106  
658/118  
Verwendung für: /  
applicable for:  
FORD  
MAZDA

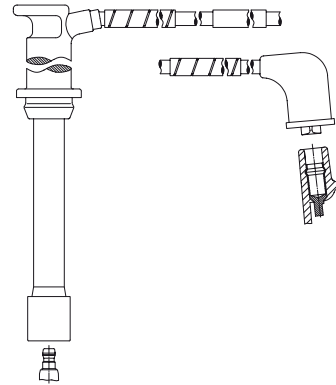

658H124  
Verwendung für: /  
applicable for:  
MAZDA

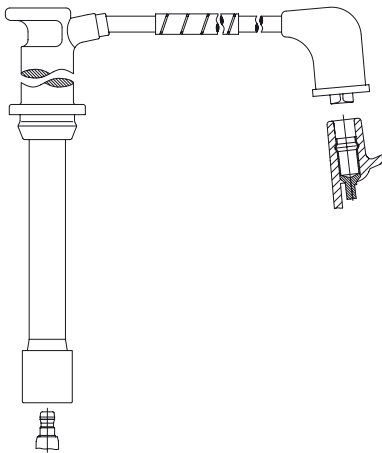

658E 67  
658E102  
658E103  
658E104  
658E108  
658E110  
658E117  
658E118  
Verwendung für: /  
applicable for:  
FORD  
MAZDA

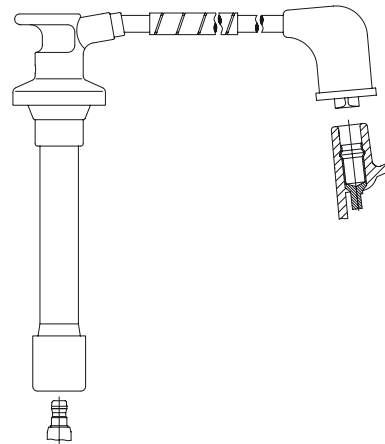

659E 45  
659E 48  
659E 54  
659E 62  
Verwendung für: /  
applicable for:  
MAZDA

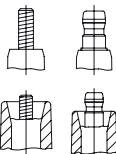

Connection spark plug: M4, SAE

Connection distributor cap: M4, SAE

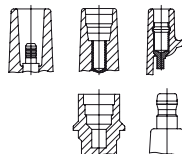

Connection distr. cap/ign. coil: 4 mm, Toyota 5 mm, DIN

Connection distr. cap/ign. coil: Ford, SAE

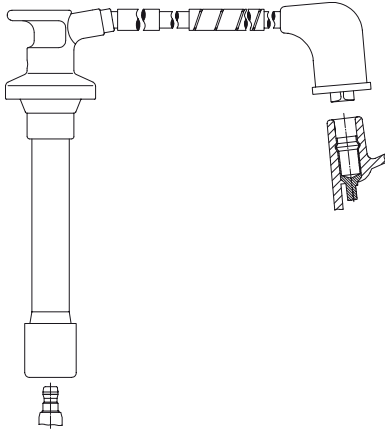

659F 47  
659F 49  
659F 61  
659F 63  
Verwendung für: /  
applicable for:  
MAZDA

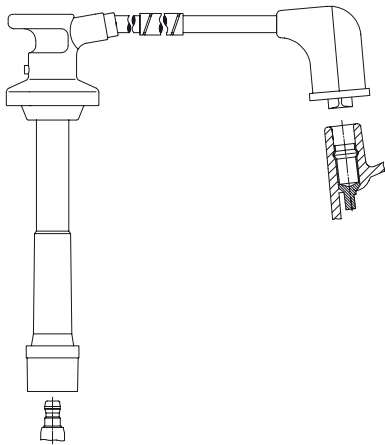

660E 31  
660E 43  
Verwendung für: /  
applicable for:  
FORD  
MAZDA

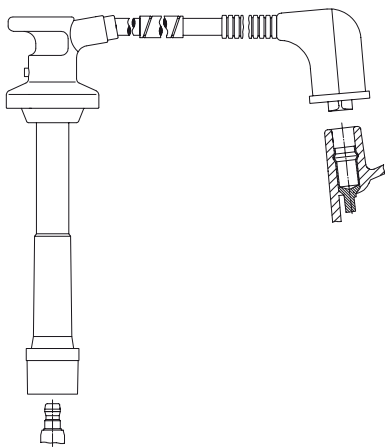

660F 46  
660F 47  
660F 60  
660F 64  
Verwendung für: /  
applicable for:  
FORD  
MAZDA



661/ 65  
Verwendung für: /  
applicable for:  
CITROEN

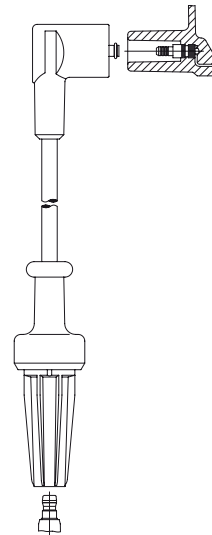

663/ 30  
663/ 36  
663/ 40  
663/ 50  
663/ 55  
663/ 61  
663/ 65  
663/ 70  
663/ 71  
663/ 75  
663/ 80  
663/ 85  
663/ 88  
663/ 90  
663/ 95  
663/ 97  
663/102  
Verwendung für: /  
applicable for:  
CITROEN  
PEUGEOT  
RENAULT  
VOLVO

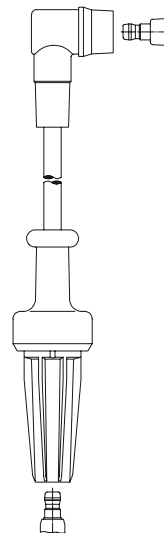

664/ 28  
Verwendung für: /  
applicable for:  
RENAULT

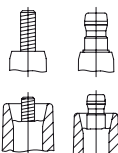

Connection spark plug: M4, SAE

Connection distributor cap: M4, SAE

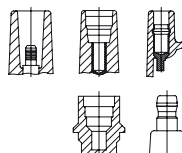

Connection distr. cap/ign. coil: 4 mm, Toyota 5 mm, DIN

Connection distr. cap/ign. coil: Ford, SAE



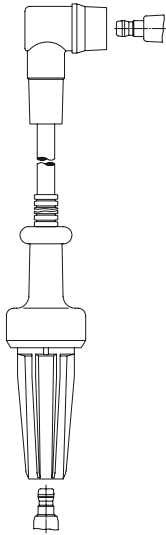

664E 36  
Verwendung für: /  
applicable for:  
RENAULT

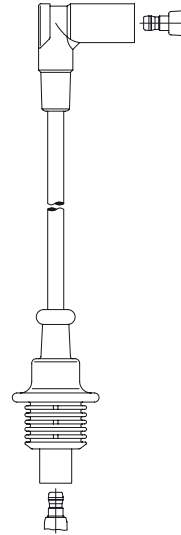

668/ 45  
668/ 48  
668/ 50  
668/ 57  
668/ 60  
668/ 63  
668/ 65  
668/ 80  
Verwendung für: /  
applicable for:  
CITROEN  
PEUGEOT

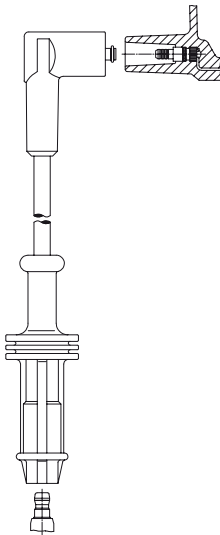

666/ 28  
666/ 35  
666/ 38  
666/ 40  
666/ 50  
666/ 55  
666/ 58  
Verwendung für: /  
applicable for:  
CITROEN  
PEUGEOT

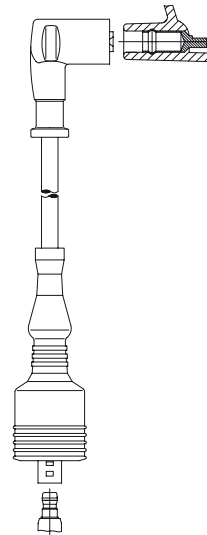

669/ 57  
669/ 66  
669/ 68  
669/ 73  
669/ 75  
669/ 78  
Verwendung für: /  
applicable for:  
ALFA ROMEO

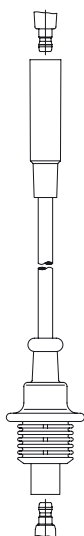

667/ 55  
667/ 65  
667/ 70  
667/ 80  
667/ 83  
667/ 90  
Verwendung für: /  
applicable for:  
CITROEN  
PEUGEOT

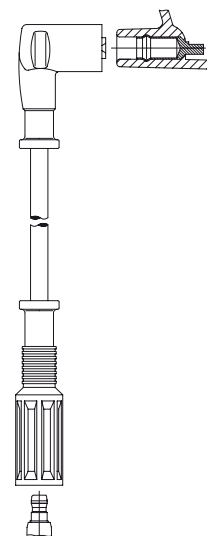

670/ 28  
670/ 35  
670/ 40  
670/ 45  
670/ 52  
670/ 55  
670/ 57  
670/ 65  
Verwendung für: /  
applicable for:  
FIAT  
LANCIA

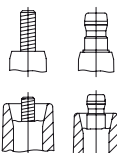

Connection spark plug: M4, SAE

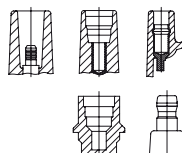

Connection distr. cap/ign. coil: 4 mm, Toyota 5 mm, DIN

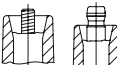

Connection distributor cap: M4, SAE



Connection distr. cap/ign. coil: Ford, SAE

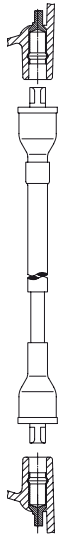

671E 86  
Verwendung für: /  
applicable for:  
VOLVO

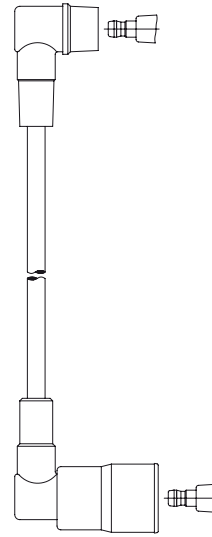

674/ 25  
674/ 26  
674/ 40  
674/ 41  
674/ 44  
674/ 50  
674/ 55  
674/ 60  
674/ 65  
Verwendung für: /  
applicable for:  
RENAULT  
VOLVO

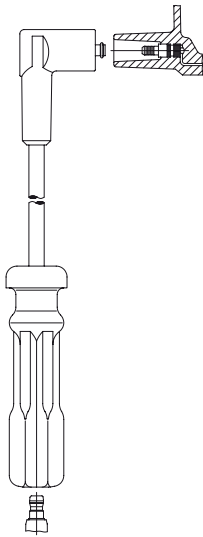

672/ 32  
672/ 40  
672/ 51  
672/ 60  
Verwendung für: /  
applicable for:  
VOLVO

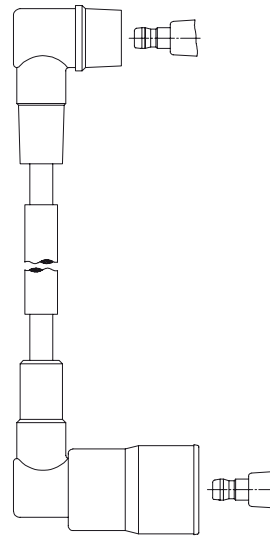

674E 25  
674E 40  
674E 43  
674E 55  
Verwendung für: /  
applicable for:  
RENAULT

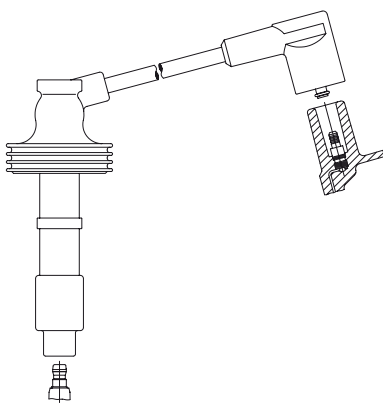

673/ 24  
673/ 35  
673/ 42  
673/ 56  
673/ 62  
Verwendung für: /  
applicable for:  
RENAULT  
VOLVO

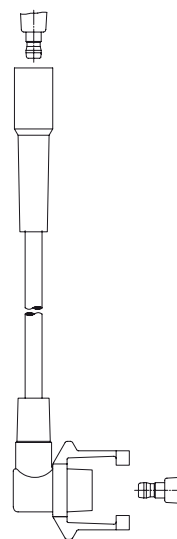

675/ 35  
675/ 45  
675/ 50  
675/ 55  
675/ 65  
675/ 90  
Verwendung für: /  
applicable for:  
RENAULT  
VOLVO

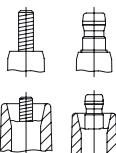

Connection spark plug: M4, SAE

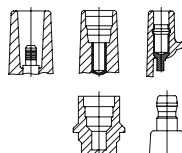

Connection distr. cap/ign. coil: 4 mm, Toyota 5 mm, DIN

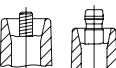

Connection distributor cap: M4, SAE



Connection distr. cap/ign. coil: Ford, SAE

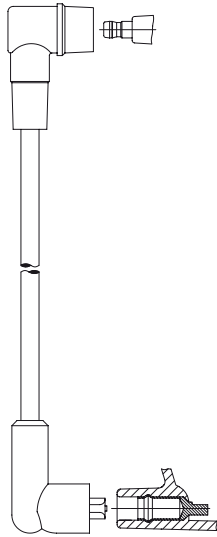

676/ 31  
676/ 95  
Verwendung für: /  
applicable for:  
VOLVO

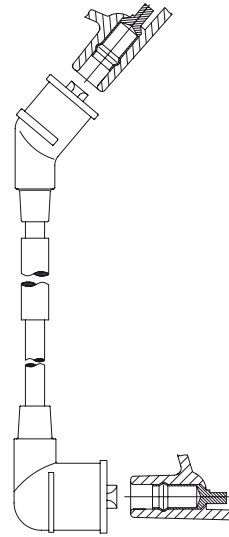

682E 27  
Verwendung für: /  
applicable for:  
NISSAN

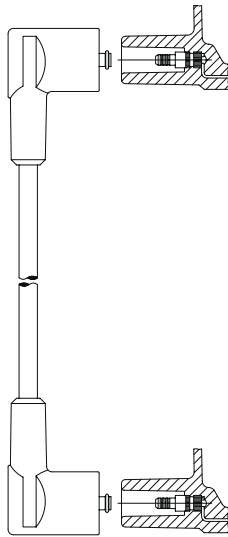

677/ 42  
677/ 46  
677/ 55  
677/ 75  
Verwendung für: /  
applicable for:  
PEUGEOT  
RENAULT  
VOLVO

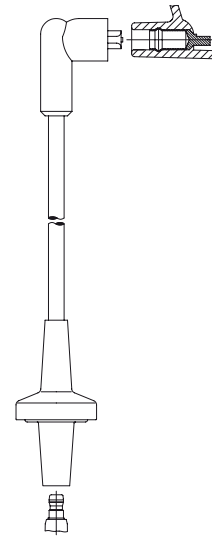

684/ 35  
684/ 40  
684/ 45  
684/ 55  
684/ 60  
Verwendung für: /  
applicable for:  
RENAULT  
VOLVO

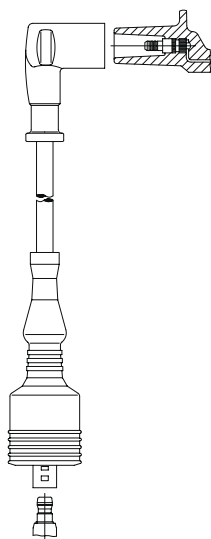

679/ 52  
679/ 56  
679/ 64  
679/ 68  
Verwendung für: /  
applicable for:  
ALFA ROMEO

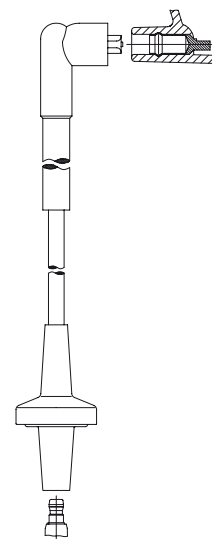

684E 40  
Verwendung für: /  
applicable for:  
RENAULT

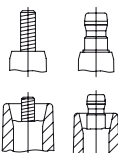

Connection spark plug: M4, SAE

Connection distributor cap: M4, SAE

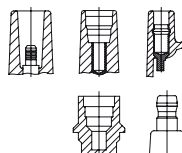

Connection distr. cap/ign. coil: 4 mm, Toyota 5 mm, DIN

Connection distr. cap/ign. coil: Ford, SAE

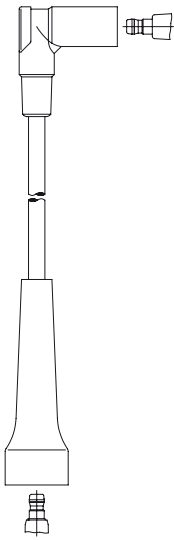

685/ 32  
 685/ 37  
 685/ 44  
 685/ 51  
 685/ 55  
 685/ 62  
 685/ 72  
 Verwendung für: /  
 applicable for:  
 RENAULT  
 VOLVO

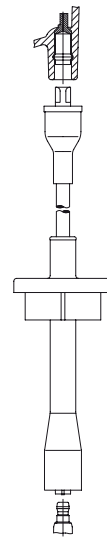

688/ 55  
 688/ 60  
 688/ 75  
 Verwendung für: /  
 applicable for:  
 TOYOTA

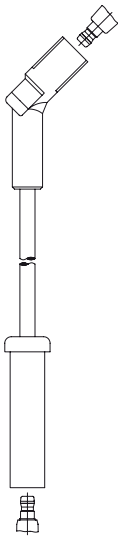

686/ 45  
 686/ 55  
 686/ 65  
 686/ 75  
 Verwendung für: /  
 applicable for:  
 CITROEN  
 PEUGEOT

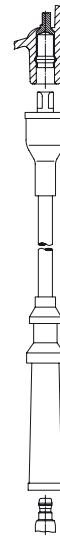

689/ 69  
 689/ 80  
 Verwendung für: /  
 applicable for:  
 VOLVO

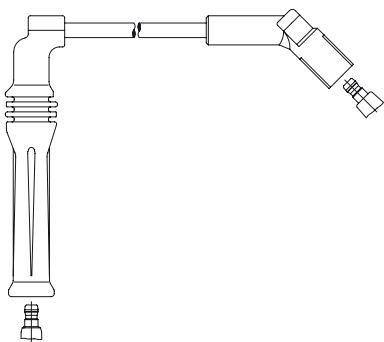

687/ 20  
 687/ 36  
 687/ 48  
 Verwendung für: /  
 applicable for:  
 CITROEN  
 PEUGEOT



690/ 30  
 690/ 45  
 690/ 50  
 690/ 60  
 Verwendung für: /  
 applicable for:  
 RENAULT  
 VOLVO

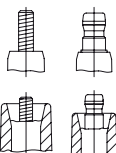

Connection spark plug: M4, SAE

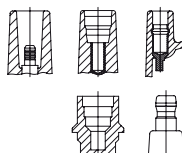

Connection distr. cap/ign. coil: 4 mm, Toyota 5 mm, DIN

Connection distributor cap: M4, SAE

Connection distr. cap/ign. coil: Ford, SAE

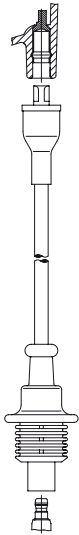

691/ 53  
 691/ 58  
 691/ 60  
 691/ 65  
 691/ 68  
 691/ 70  
 691/ 80  
 691/ 93  
 Verwendung für: /  
 applicable for:  
 CITROEN  
 PEUGEOT

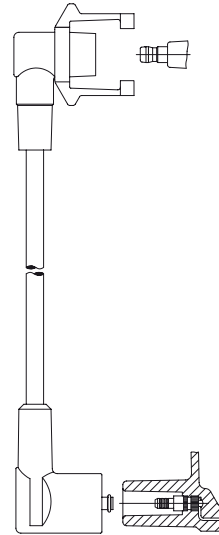

695/ 60  
 695/ 86  
 Verwendung für: /  
 applicable for:  
 RENAULT  
 VOLVO

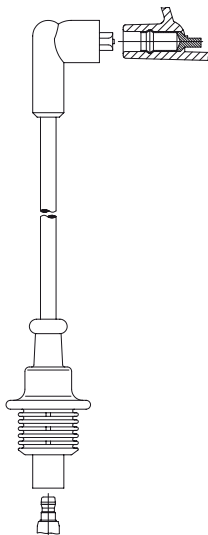

692/ 45  
 692/ 55  
 692/ 60  
 Verwendung für: /  
 applicable for:  
 CITROEN

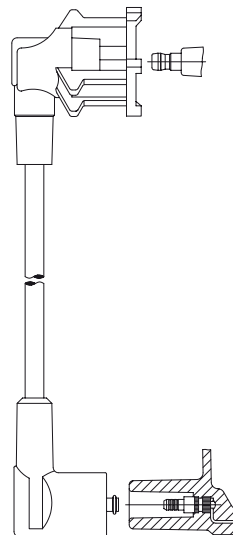

696/ 70  
 Verwendung für: /  
 applicable for:  
 RENAULT

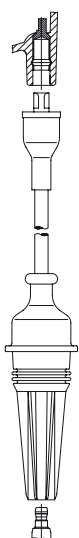

694/ 60  
 694/ 65  
 694/ 75  
 694/ 80  
 Verwendung für: /  
 applicable for:  
 PEUGEOT

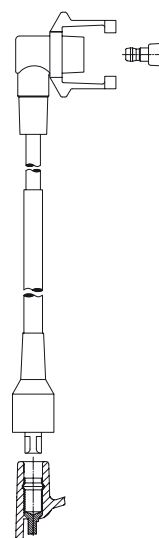

698E 85  
 Verwendung für: /  
 applicable for:  
 RENAULT  
 VOLVO

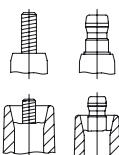

Connection spark plug: M4, SAE

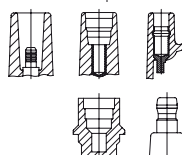

Connection distr. cap/ign. coil: 4 mm, Toyota 5 mm, DIN



Connection distributor cap: M4, SAE



Connection distr. cap/ign. coil: Ford, SAE

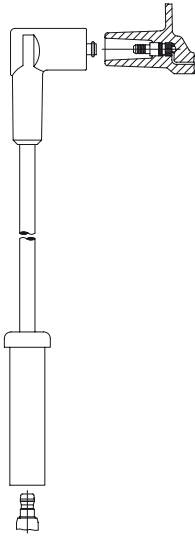

699/ 40  
699/ 45  
699/ 55  
699/ 60  
699/ 72  
699/ 80  
Verwendung für: /  
applicable for:  
CITROEN  
FIAT  
LANCIA  
PEUGEOT

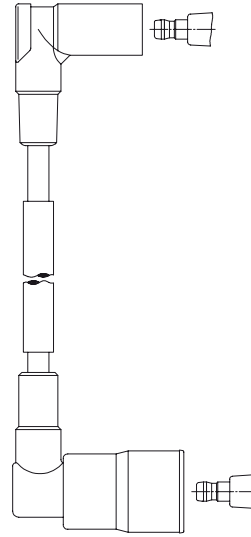

703E 50  
703E 60  
703E 63  
Verwendung für: /  
applicable for:  
RENAULT

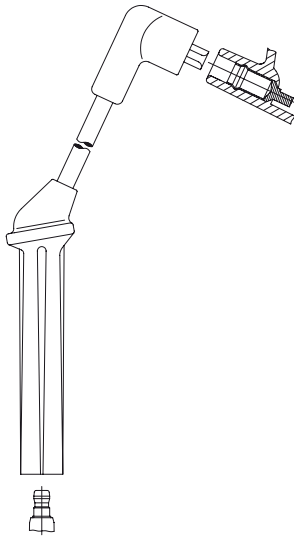

701/ 32  
701/ 46  
701/ 50  
701/ 65  
Verwendung für: /  
applicable for:  
SAAB

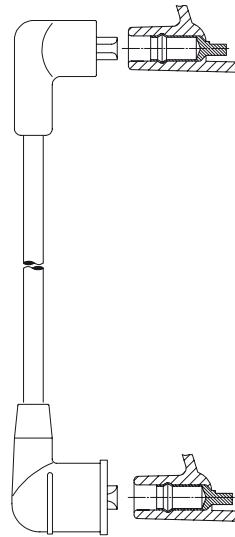

705/ 16  
Verwendung für: /  
applicable for:  
INFINITI  
NISSAN

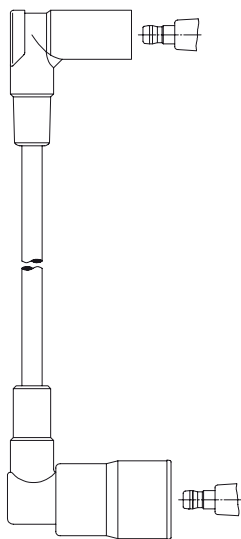

703/ 50  
703/ 63  
Verwendung für: /  
applicable for:  
RENAULT

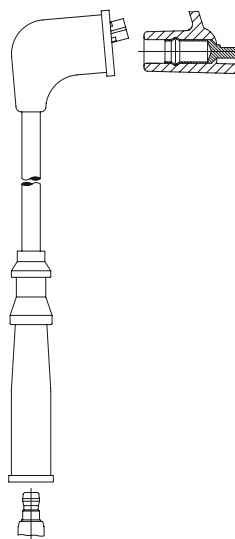

708/ 35  
708/ 42  
708/ 48  
708/ 50  
708/ 52  
708/ 56  
708/ 64  
708/ 68  
708/ 70  
708/ 73  
708/ 76  
708/ 80  
708/ 90  
708/ 96  
Verwendung für: /  
applicable for:  
MAZDA

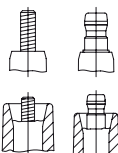

Connection spark plug: M4, SAE

Connection distributor cap: M4, SAE

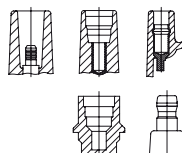

Connection distr. cap/ign. coil: 4 mm, Toyota 5 mm, DIN

Connection distr. cap/ign. coil: Ford, SAE

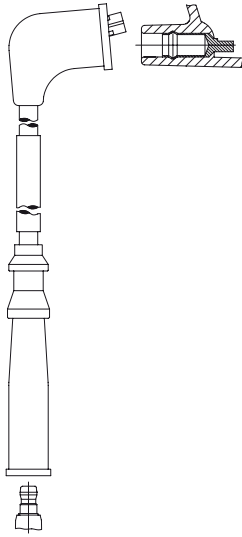

708E 52  
708E 69  
Verwendung für: /  
applicable for:  
MAZDA

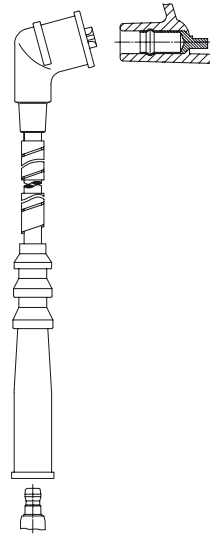

709F 34  
Verwendung für: /  
applicable for:  
TOYOTA

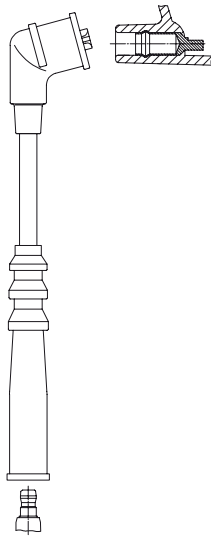

709/ 27  
709/ 30  
709/ 32  
709/ 34  
709/ 36  
709/ 39  
709/ 40  
709/ 43  
709/ 44  
709/ 48  
709/ 51  
709/ 54  
709/ 59  
709/ 62  
709/ 64  
709/ 66  
709/ 69  
Verwendung für: /  
applicable for:  
FORD  
NISSAN  
TOYOTA

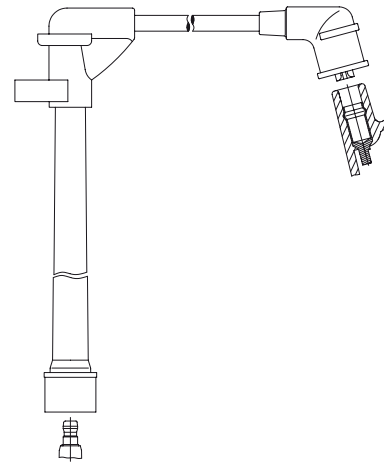

710/ 65  
Verwendung für: /  
applicable for:  
NISSAN

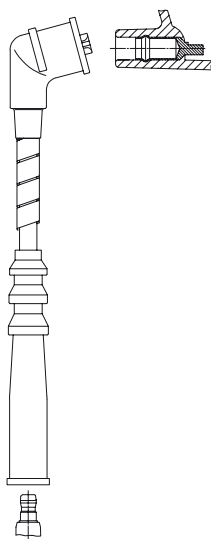

709E 35  
709E 46  
709E 54  
709E 57  
709E 61  
Verwendung für: /  
applicable for:  
NISSAN

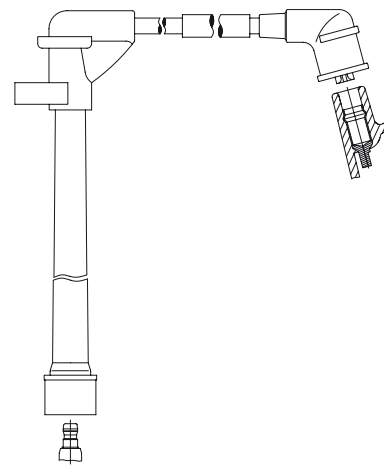

710E 69  
Verwendung für: /  
applicable for:  
NISSAN

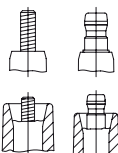

Connection spark plug: M4, SAE

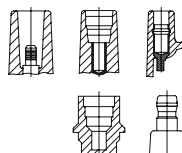

Connection distr. cap/ign. coil: 4 mm, Toyota 5 mm, DIN

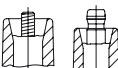

Connection distributor cap: M4, SAE



Connection distr. cap/ign. coil: Ford, SAE

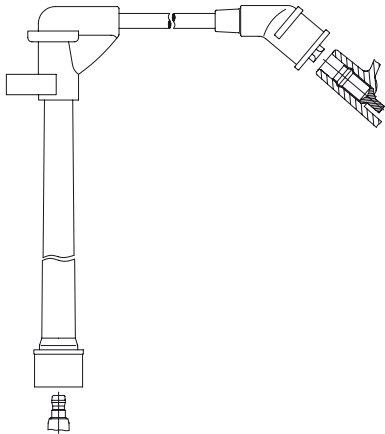

711/ 68  
Verwendung für: /  
applicable for:  
NISSAN

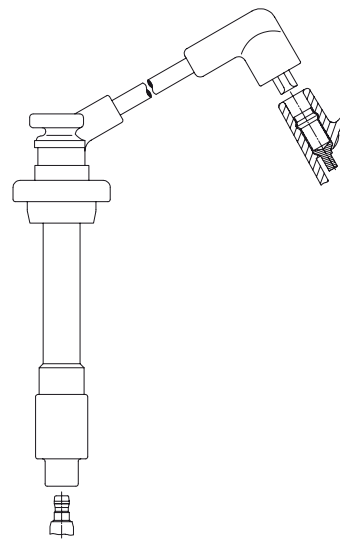

717/ 28  
717/ 37  
Verwendung für: /  
applicable for:  
INFINITI  
NISSAN

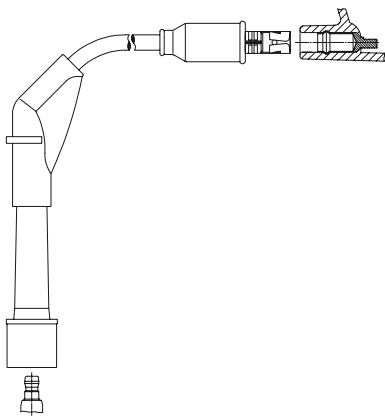

712/ 45  
712/ 57  
Verwendung für: /  
applicable for:  
NISSAN

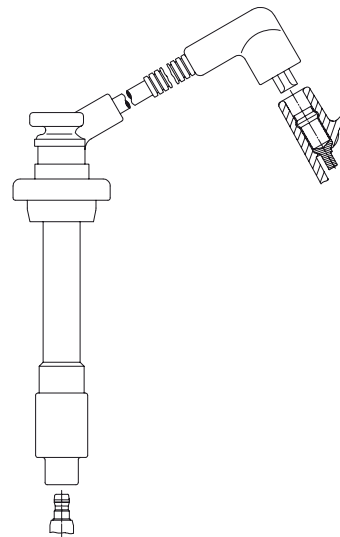

717E 55  
717E 60  
Verwendung für: /  
applicable for:  
INFINITI  
NISSAN

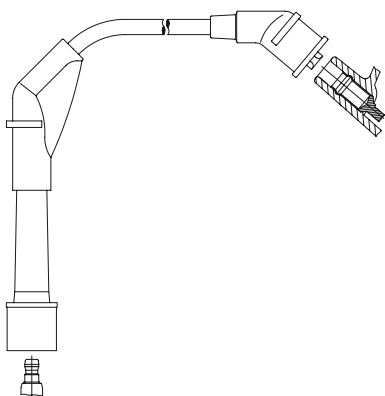

713/ 36  
Verwendung für: /  
applicable for:  
NISSAN

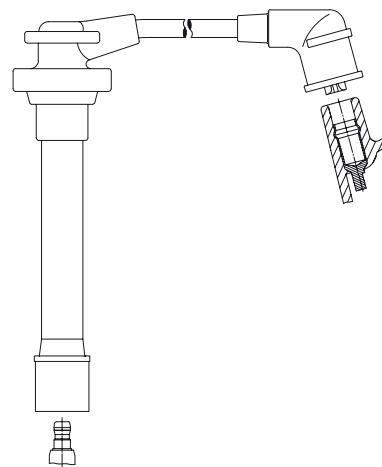

718/ 31  
718/ 36  
718/ 41  
718/ 50  
718/ 54  
718/ 56  
718/ 61  
718/ 65  
Verwendung für: /  
applicable for:  
NISSAN

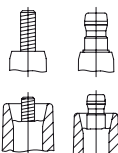

Connection spark plug: M4, SAE

Connection distributor cap: M4, SAE

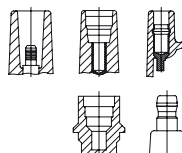

Connection distr. cap/ign. coil: 4 mm, Toyota 5 mm, DIN

Connection distr. cap/ign. coil: Ford, SAE



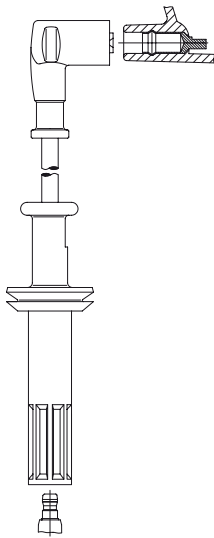

721/ 42  
721/ 46  
721/ 53  
721/ 58  
721/ 61  
721/ 67  
721/ 71  
Verwendung für: /  
applicable for:  
FIAT  
LANCIA

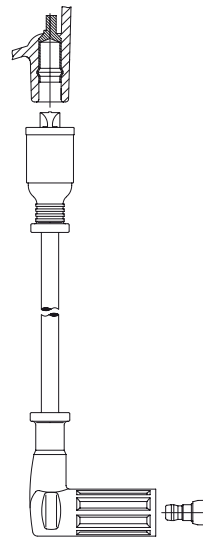

724/ 18  
724/ 23  
724/ 31  
724/ 33  
724/ 38  
724/ 40  
724/ 42  
724/ 47  
724/ 52  
724/ 54  
724/ 58  
724/ 63  
724/ 68  
Verwendung für: /  
applicable for:  
FIAT  
LANCIA

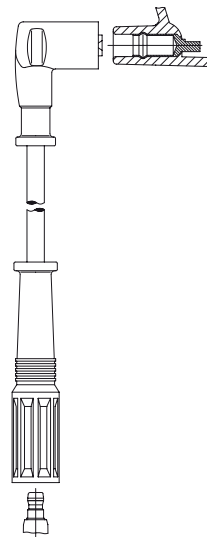

722/ 30  
722/ 33  
722/ 36  
722/ 41  
722/ 48  
722/ 50  
722/ 56  
722/ 70  
Verwendung für: /  
applicable for:  
ALFA ROMEO  
FIAT  
LANCIA



725/ 22  
725/ 28  
725/ 31  
725/ 38  
725/ 40  
725/ 42  
725/ 45  
725/ 47  
725/ 50  
725/ 53  
725/ 58  
725/ 60  
725/ 68  
Verwendung für: /  
applicable for:  
FIAT  
LANCIA

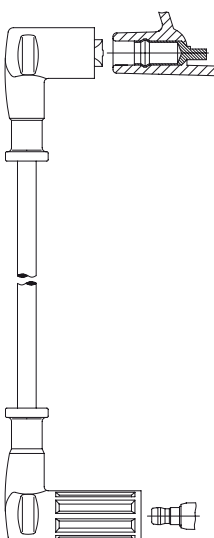

723/ 20  
723/ 24  
723/ 31  
723/ 35  
723/ 38  
723/ 40  
723/ 48  
723/ 57  
723/ 63  
Verwendung für: /  
applicable for:  
FIAT  
LANCIA

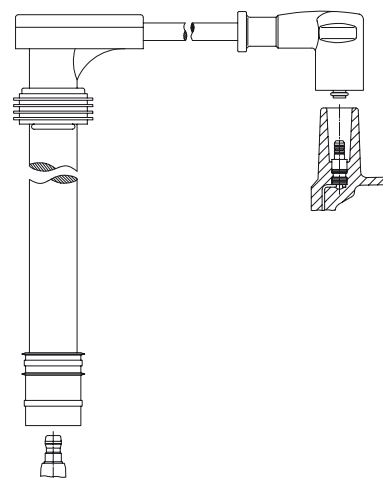

726/ 25  
726/ 35  
726/ 45  
726/ 50  
Verwendung für: /  
applicable for:  
FIAT  
LANCIA

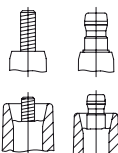

Connection spark plug: M4, SAE

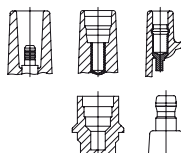

Connection distr. cap/ign. coil: 4 mm, Toyota 5 mm, DIN

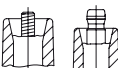

Connection distributor cap: M4, SAE



Connection distr. cap/ign. coil: Ford, SAE

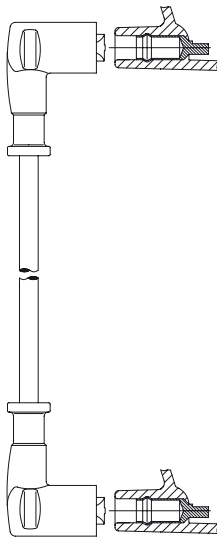

728/ 30  
728/ 32  
728/ 43  
728/ 60  
728/ 63  
Verwendung für: /  
applicable for:  
ALFA ROMEO  
FIAT  
LANCIA

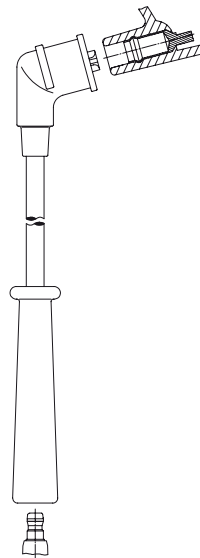

731/ 32  
731/ 35  
731/ 42  
731/ 47  
731/ 49  
731/ 52  
731/ 53  
731/ 57  
731/ 64  
731/ 67  
731/ 69  
731/ 80  
Verwendung für: /  
applicable for:  
DAIHATSU  
FORD  
MAZDA  
TOYOTA

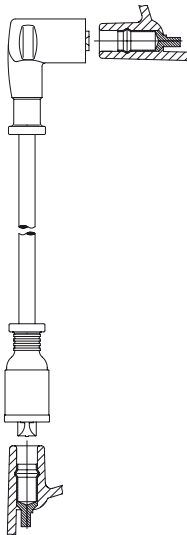

729/ 27  
729/ 37  
729/ 43  
729/ 50  
729/ 55  
729/ 58  
729/ 73  
729/ 88  
729/118  
Verwendung für: /  
applicable for:  
ALFA ROMEO  
FIAT  
LANCIA

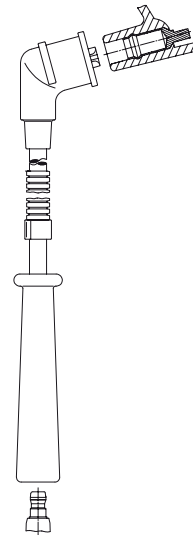

731E 49  
731E 66  
Verwendung für: /  
applicable for:  
MAZDA  
TOYOTA

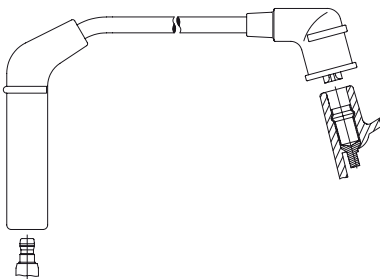

730/ 33  
730/ 39  
730/ 50  
730/ 58  
730/ 67  
730/ 80  
Verwendung für: /  
applicable for:  
HYUNDAI  
TOYOTA

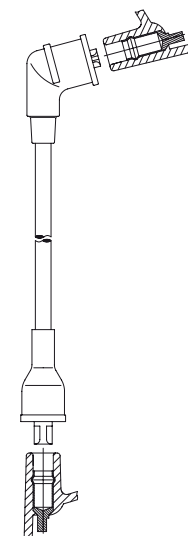

732/ 37  
732/ 52  
Verwendung für: /  
applicable for:  
TOYOTA

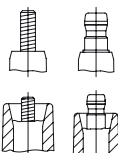

Connection spark plug: M4, SAE

Connection distributor cap: M4, SAE

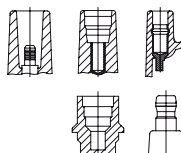

Connection distr. cap/ign. coil: 4 mm, Toyota 5 mm, DIN

Connection distr. cap/ign. coil: Ford, SAE

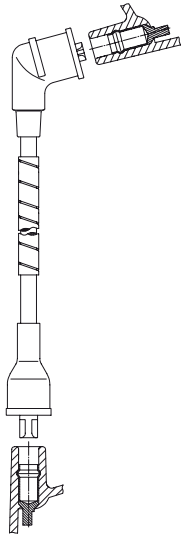

732E 33  
Verwendung für: /  
applicable for:  
TOYOTA

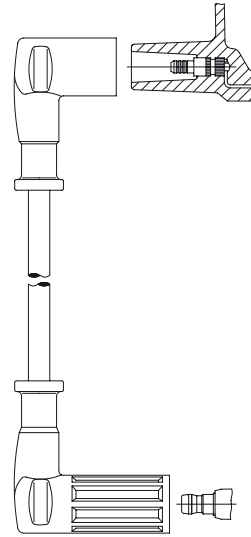

735/ 35  
735/ 40  
735/ 52  
735/ 68  
Verwendung für: /  
applicable for:  
FIAT  
LANCIA

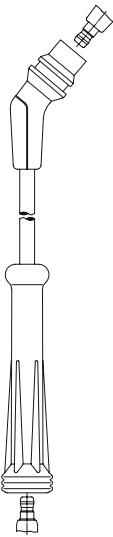

733/ 44  
733/ 58  
733/ 70  
Verwendung für: /  
applicable for:  
RENAULT



736E 33  
Verwendung für: /  
applicable for:  
SAAB

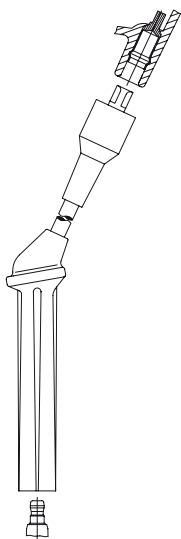

734/ 30  
734/ 37  
734/ 51  
734/ 59  
Verwendung für: /  
applicable for:  
SAAB

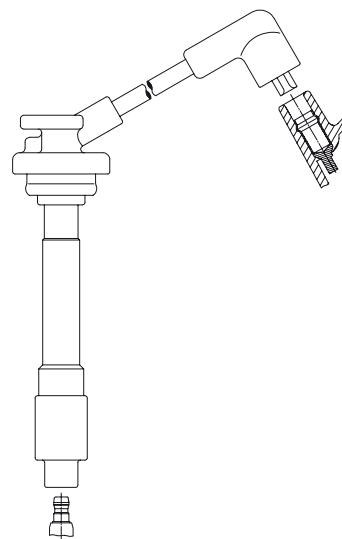

737/ 31  
737/ 35  
737/ 52  
737/ 56  
Verwendung für: /  
applicable for:  
NISSAN

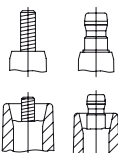

Connection spark plug: M4, SAE

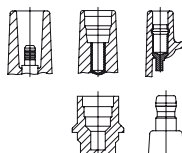

Connection distr. cap/ign. coil: 4 mm, Toyota 5 mm, DIN

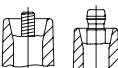

Connection distributor cap: M4, SAE



Connection distr. cap/ign. coil: Ford, SAE

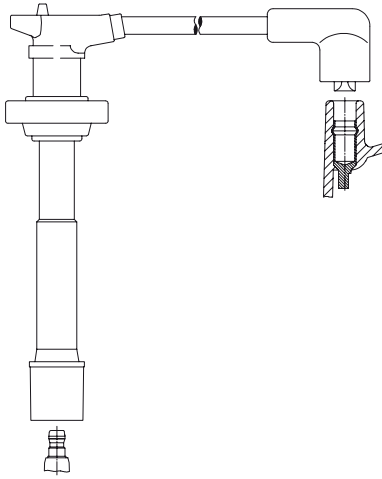

738/ 40  
738/ 48  
738/ 52  
738/ 58  
Verwendung für: /  
applicable for:  
NISSAN

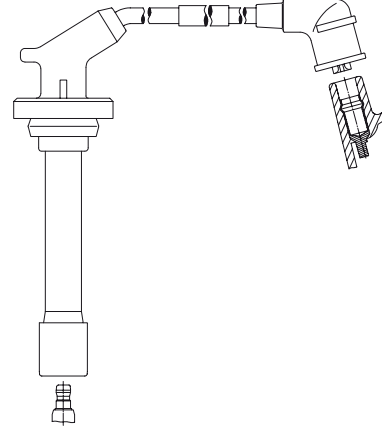

739E 67  
Verwendung für: /  
applicable for:  
HONDA

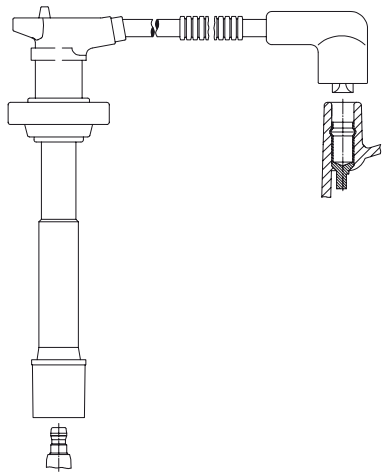

738E 32  
738E 34  
738E 35  
738E 50  
738E 54  
Verwendung für: /  
applicable for:  
NISSAN

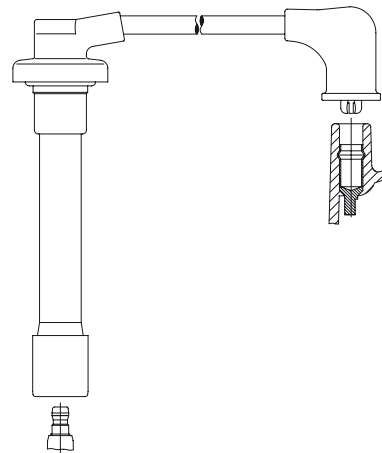

740/ 33  
740/ 36  
740/ 38  
740/ 42  
740/ 44  
740/ 53  
740/ 55  
740/ 56  
740/ 60  
740/ 66  
740/ 80  
Verwendung für: /  
applicable for:  
HONDA

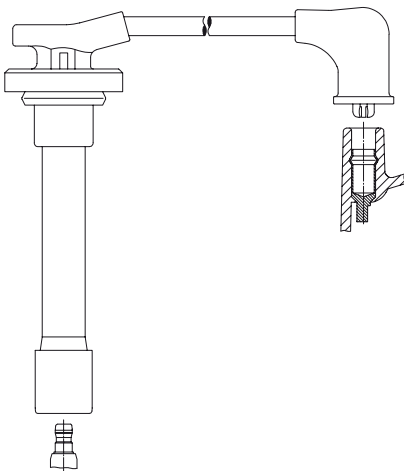

739/ 32  
739/ 39  
739/ 45  
739/ 48  
739/ 54  
739/ 56  
739/ 60  
739/ 66  
739/ 68  
Verwendung für: /  
applicable for:  
HONDA  
ROVER

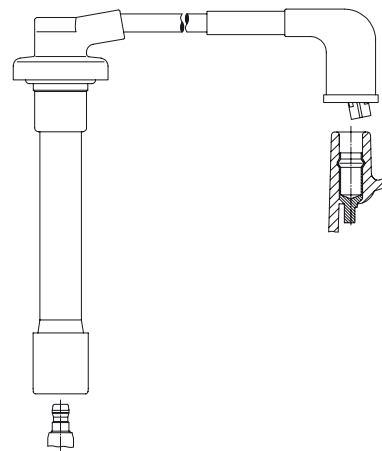

740E 80  
740E 94  
Verwendung für: /  
applicable for:  
HONDA

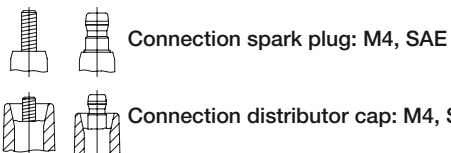

Connection spark plug: M4, SAE

Connection distributor cap: M4, SAE

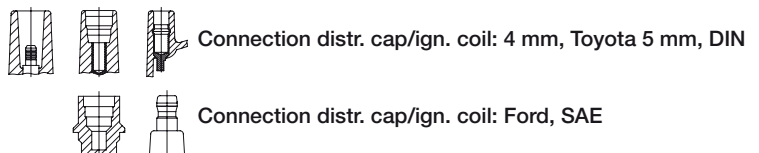

Connection distr. cap/ign. coil: 4 mm, Toyota 5 mm, DIN

Connection distr. cap/ign. coil: Ford, SAE

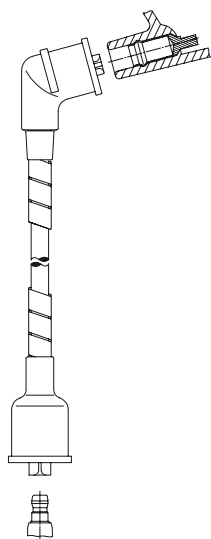

741F 63  
Verwendung für: /  
applicable for:  
NISSAN

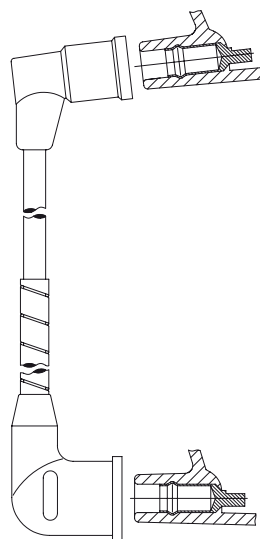

749E 32  
Verwendung für: /  
applicable for:  
NISSAN

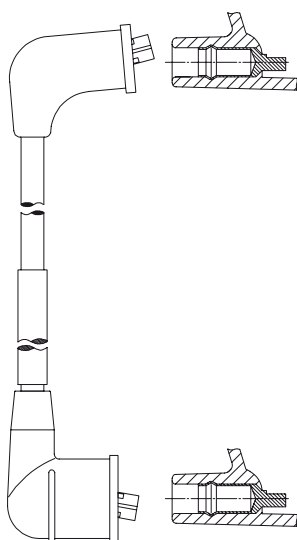

747E 75  
Verwendung für: /  
applicable for:  
MAZDA

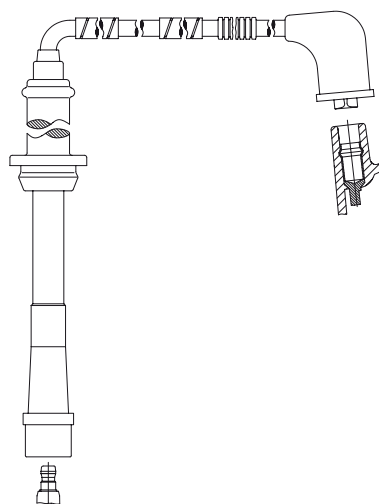

750H 98  
Verwendung für: /  
applicable for:  
MAZDA

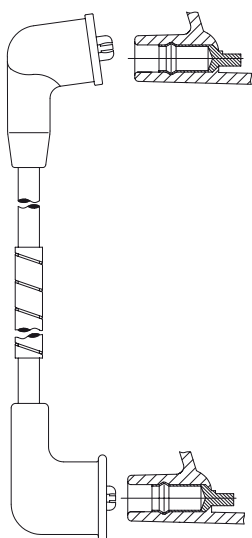

748E 70  
Verwendung für: /  
applicable for:  
FORD  
NISSAN



751/ 65  
751/ 77  
Verwendung für: /  
applicable for:  
VOLVO

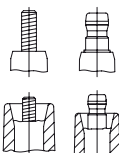

Connection spark plug: M4, SAE

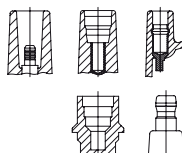

Connection distr. cap/ign. coil: 4 mm, Toyota 5 mm, DIN



Connection distributor cap: M4, SAE



Connection distr. cap/ign. coil: Ford, SAE

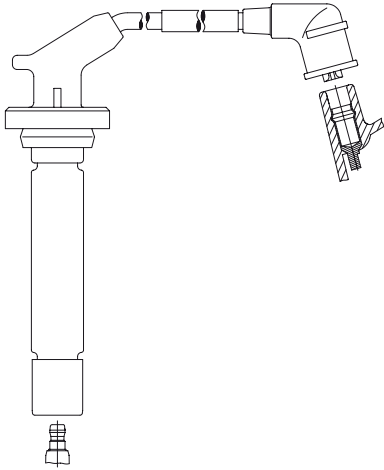

754E 36  
754E 39  
754E 44  
754E 46  
754E 47  
754E 89  
754E 89  
754E 92  
Verwendung für: /  
applicable for:  
ROVER

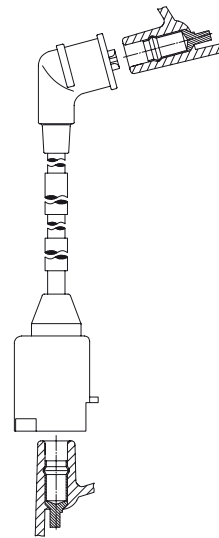

756F 68  
Verwendung für: /  
applicable for:  
ROVER

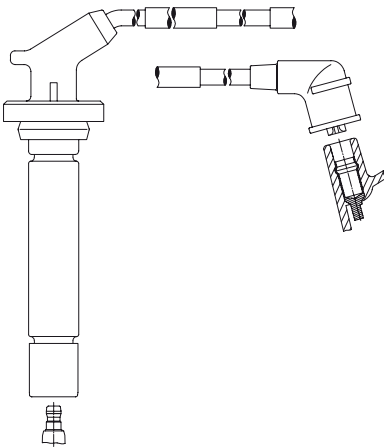

754F 87  
754F 89  
754F 98  
Verwendung für: /  
applicable for:  
ROVER

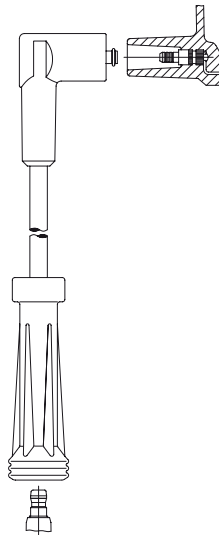

759/ 40  
759/ 44  
759/ 50  
759/ 59  
Verwendung für: /  
applicable for:  
RENAULT

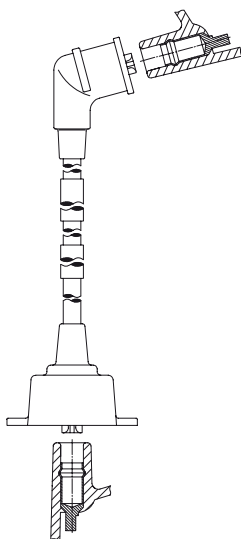

755F 68  
Verwendung für: /  
applicable for:  
ROVER

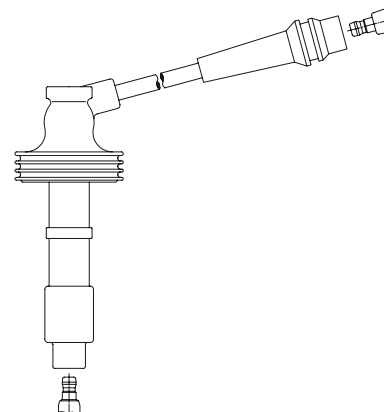

760/ 22  
760/ 35  
Verwendung für: /  
applicable for:  
RENAULT  
VOLVO

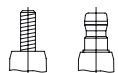

Connection spark plug: M4, SAE

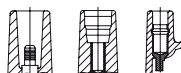

Connection distr. cap/ign. coil: 4 mm, Toyota 5 mm, DIN

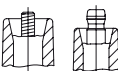

Connection distributor cap: M4, SAE



Connection distr. cap/ign. coil: Ford, SAE

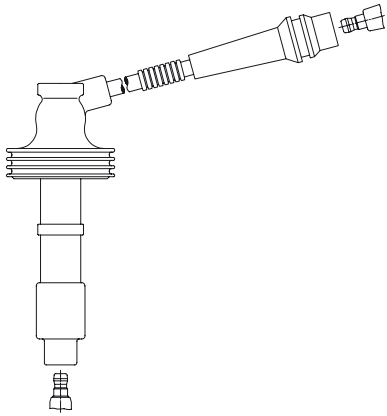

760E 22  
Verwendung für: /  
applicable for:  
RENAULT  
VOLVO

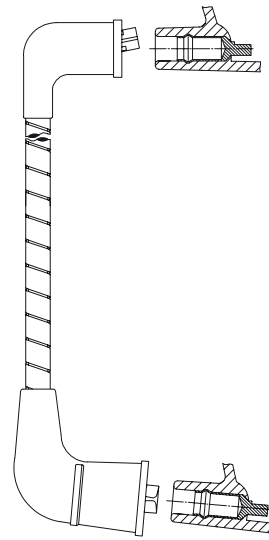

763E 58  
Verwendung für: /  
applicable for:  
MAZDA

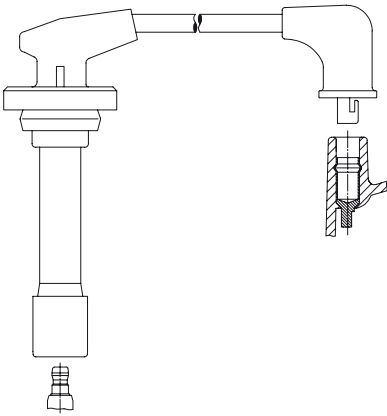

761/ 35  
761/ 40  
761/ 60  
Verwendung für: /  
applicable for:  
HONDA  
ROVER

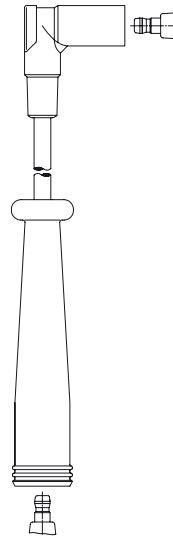

764/ 45  
764/ 65  
Verwendung für: /  
applicable for:  
RENAULT

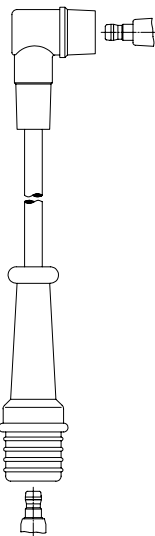

762/ 35  
762/ 38  
762/ 55  
762/ 62  
Verwendung für: /  
applicable for:  
RENAULT

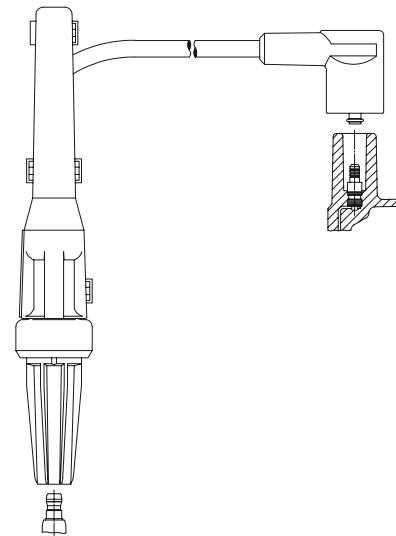

766/ 68  
766/ 73  
Verwendung für: /  
applicable for:  
RENAULT

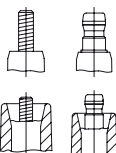

Connection spark plug: M4, SAE

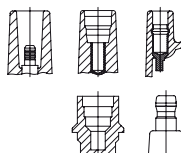

Connection distr. cap/ign. coil: 4 mm, Toyota 5 mm, DIN

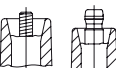

Connection distributor cap: M4, SAE



Connection distr. cap/ign. coil: Ford, SAE

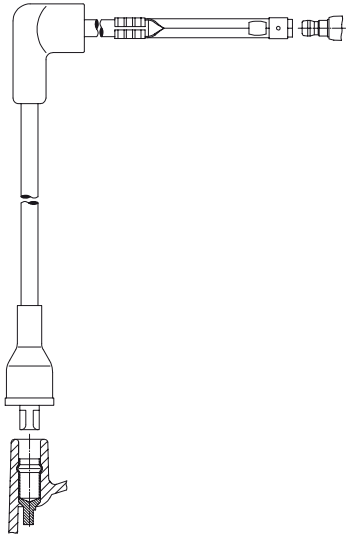

768/ 33  
768/ 47  
768/ 63  
768/ 72  
Verwendung für: /  
applicable for:  
FIAT

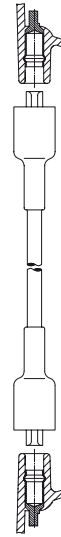

771/ 37  
771/ 48  
771/ 53  
Verwendung für: /  
applicable for:  
FIAT  
LANCIA

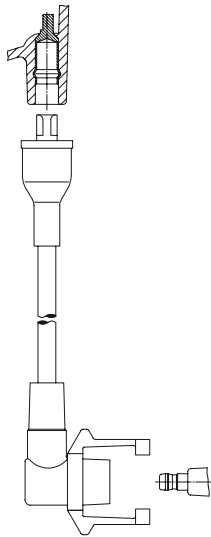

769/ 36  
769/ 68  
769/ 83  
Verwendung für: /  
applicable for:  
RENAULT

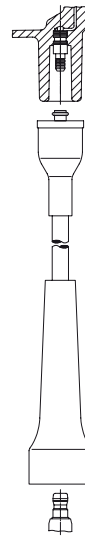

773/ 29  
773/ 31  
773/ 40  
Verwendung für: /  
applicable for:  
RENAULT

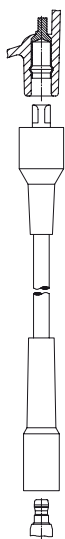

770/ 35  
770/ 42  
770/ 47  
770/ 57  
770/ 67  
Verwendung für: /  
applicable for:  
OPEL  
RENAULT  
SEAT

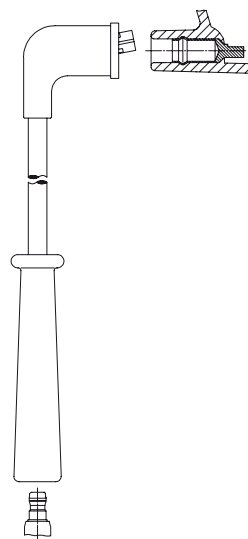

774/ 50  
774/ 53  
774/ 61  
774/ 68  
774/ 71  
Verwendung für: /  
applicable for:  
SUBARU  
SUZUKI  
TOYOTA

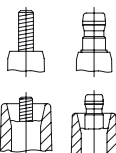

Connection spark plug: M4, SAE

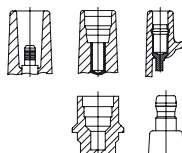

Connection distr. cap/ign. coil: 4 mm, Toyota 5 mm, DIN

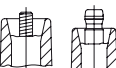

Connection distributor cap: M4, SAE



Connection distr. cap/ign. coil: Ford, SAE



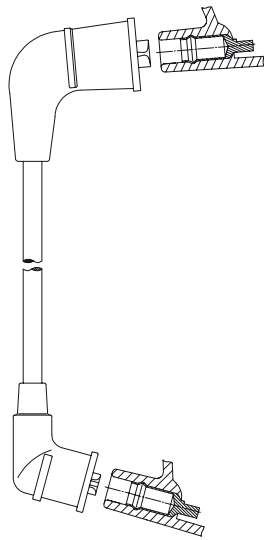

775/ 40  
775/ 45  
Verwendung für: /  
applicable for:  
SUBARU  
SUZUKI

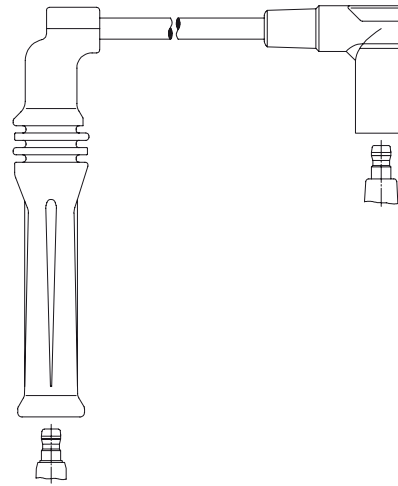

777/ 25  
Verwendung für: /  
applicable for:  
CITROEN  
PEUGEOT

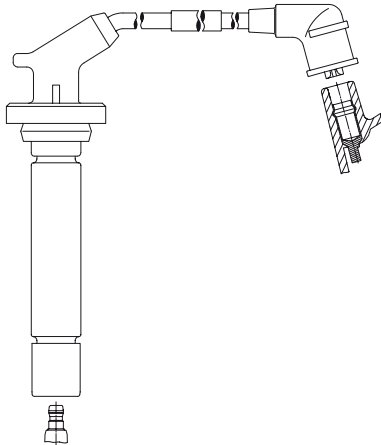

776E 36  
776E 39  
776E 44  
776E 46  
776E 47  
776E 89  
776E 92  
Verwendung für: /  
applicable for:  
ROVER

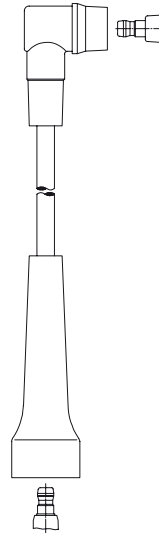

779/ 35  
779/ 37  
779/ 48  
779/ 52  
779/ 54  
779/ 55  
779/ 64  
779/ 72  
Verwendung für: /  
applicable for:  
RENAULT

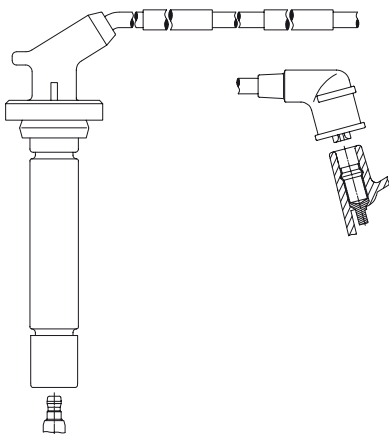

776F 87  
776F 89  
776F 98  
Verwendung für: /  
applicable for:  
ROVER

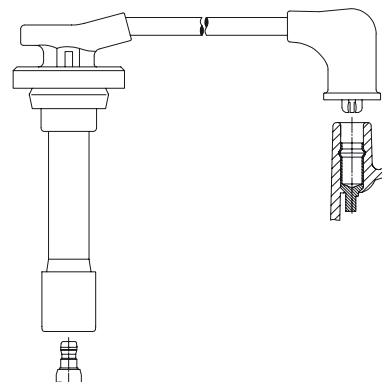

781/ 57  
Verwendung für: /  
applicable for:  
HONDA

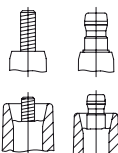

Connection spark plug: M4, SAE

Connection distributor cap: M4, SAE

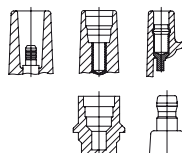

Connection distr. cap/ign. coil: 4 mm, Toyota 5 mm, DIN

Connection distr. cap/ign. coil: Ford, SAE

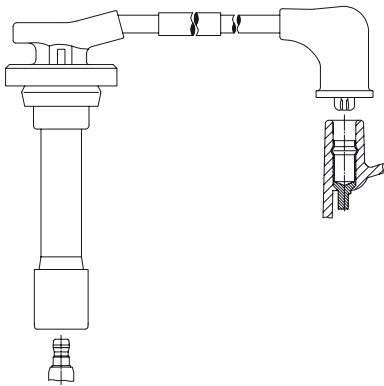

781E 34  
781E 40  
781E 58  
Verwendung für: /  
applicable for:  
HONDA

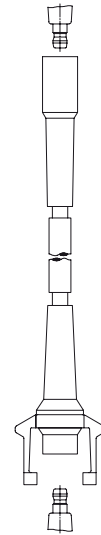

788E 48  
Verwendung für: /  
applicable for:  
RENAULT

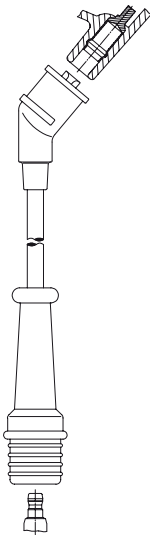

783/ 53  
783/ 61  
Verwendung für: /  
applicable for:  
RENAULT

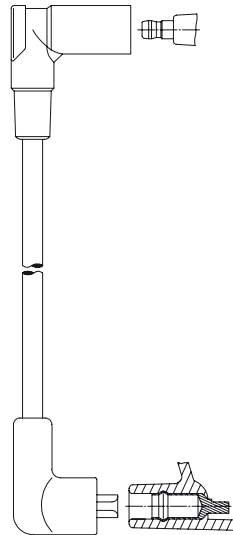

790/ 38  
Verwendung für: /  
applicable for:  
CITROEN

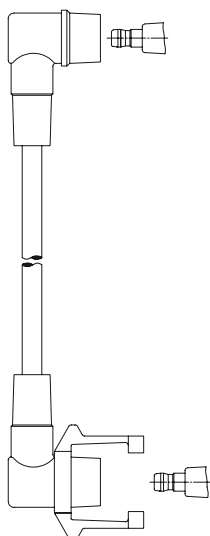

787/ 40  
787/ 63  
Verwendung für: /  
applicable for:  
RENAULT

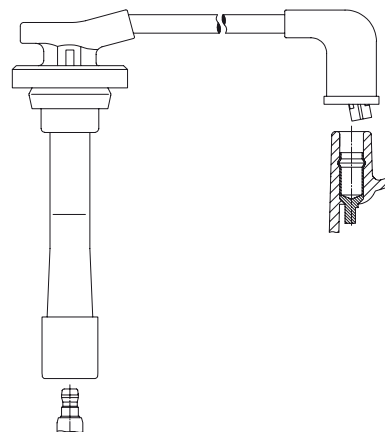

792/ 22  
792/ 31  
792/ 41  
Verwendung für: /  
applicable for:  
HONDA

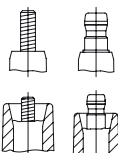

Connection spark plug: M4, SAE

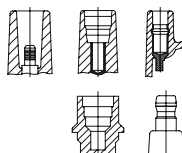

Connection distr. cap/ign. coil: 4 mm, Toyota 5 mm, DIN

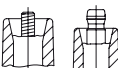

Connection distributor cap: M4, SAE



Connection distr. cap/ign. coil: Ford, SAE

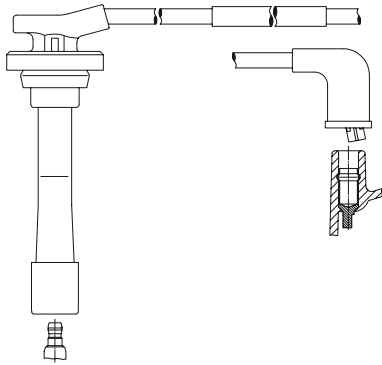

792E 50  
792E 51  
Verwendung für: /  
applicable for:  
HONDA

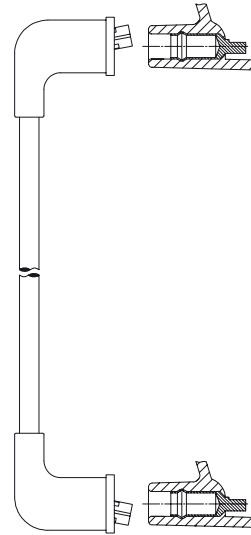

797/ 43  
797/ 48  
Verwendung für: /  
applicable for:  
DAIHATSU

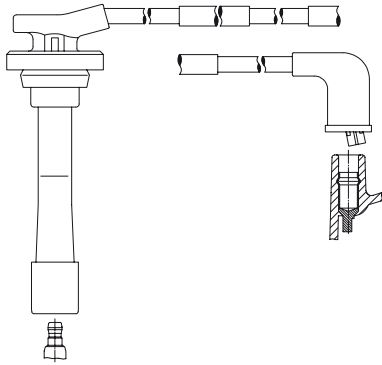

792F 30  
792F 47  
792F 66  
Verwendung für: /  
applicable for:  
HONDA



798/ 85  
Verwendung für: /  
applicable for:  
CITROEN



794/ 41  
794/ 48  
794/ 62  
794/ 70  
Verwendung für: /  
applicable for:  
FIAT  
LANCIA

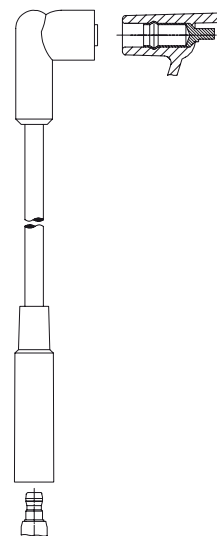

799/ 45  
799/ 58  
799/ 61  
799/ 74  
Verwendung für: /  
applicable for:  
CITROEN  
MITSUBISHI  
SEAT

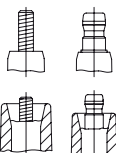

Connection spark plug: M4, SAE

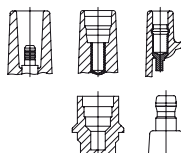

Connection distributor cap: M4, SAE

Connection distr. cap/ign. coil: 4 mm, Toyota 5 mm, DIN

Connection distr. cap/ign. coil: Ford, SAE

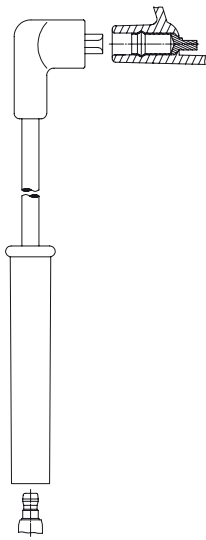

8A10/ 46  
 8A10/ 53  
 8A10/ 55  
 8A10/ 60  
 8A10/ 69  
 8A10/ 73  
 8A10/ 80  
 Verwendung für: /  
 applicable for:  
 FORD



8A13E 66  
 8A13E 76  
 Verwendung für: /  
 applicable for:  
 FORD

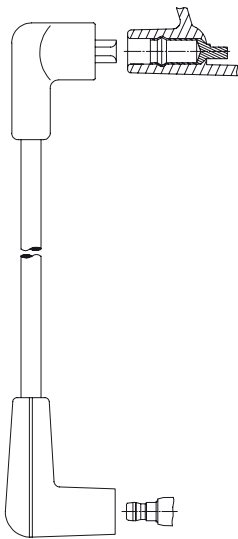

8A11/ 65  
 Verwendung für: /  
 applicable for:  
 FORD

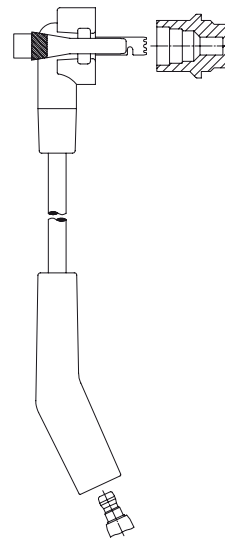

8A14/ 37  
 8A14/ 61  
 8A14/ 74  
 8A14/ 78  
 8A14/ 89  
 8A14/ 92  
 8A14/100  
 Verwendung für: /  
 applicable for:  
 FORD  
 MAZDA

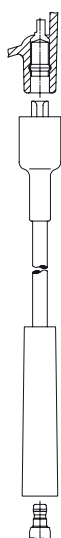

8A13/ 61  
 8A13/ 70  
 Verwendung für: /  
 applicable for:  
 FORD

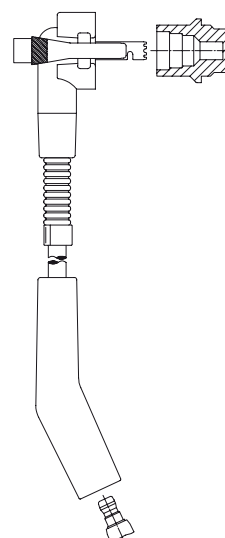

8A14E 84  
 Verwendung für: /  
 applicable for:  
 MAZDA

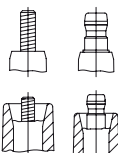

Connection spark plug: M4, SAE

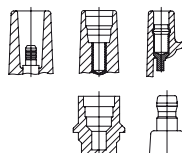

Connection distr. cap/ign. coil: 4 mm, Toyota 5 mm, DIN

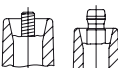

Connection distributor cap: M4, SAE



Connection distr. cap/ign. coil: Ford, SAE

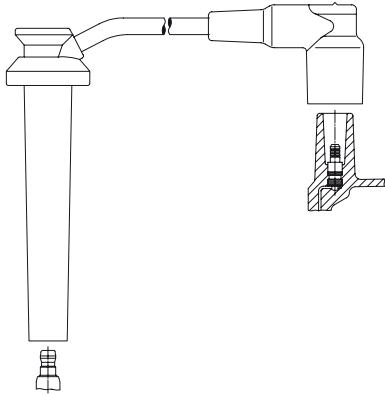

8A15/ 90  
Verwendung für: /  
applicable for:  
FORD  
MERCURY

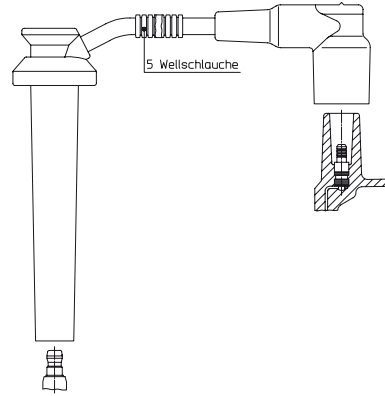

8A15P 87  
Verwendung für: /  
applicable for:  
FORD

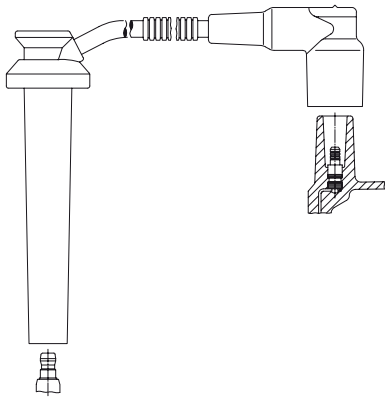

8A15E 31  
8A15E 34  
8A15E 37  
8A15E 64  
8A15E 76  
8A15E 96  
Verwendung für: /  
applicable for:  
FORD  
MERCURY

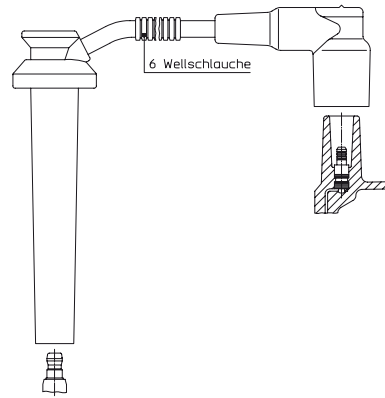

8A15R110  
8A15R116  
Verwendung für: /  
applicable for:  
FORD

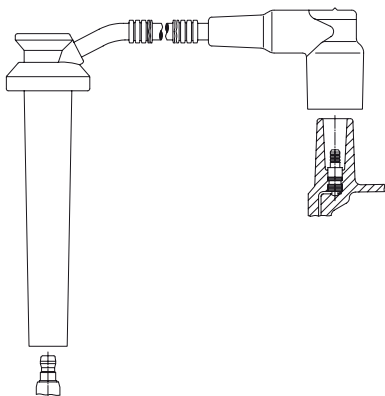

8A15F 29  
Verwendung für: /  
applicable for:  
FORD

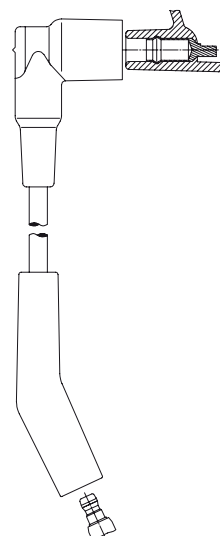

8A16/ 78  
8A16/ 84  
8A16/ 90  
8A16/ 93  
Verwendung für: /  
applicable for:  
FORD

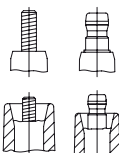

Connection spark plug: M4, SAE

Connection distributor cap: M4, SAE

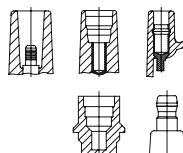

Connection distr. cap/ign. coil: 4 mm, Toyota 5 mm, DIN

Connection distr. cap/ign. coil: Ford, SAE

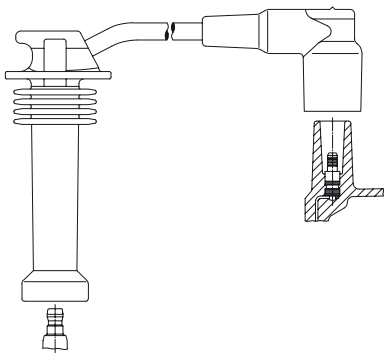

8A17/ 15  
 8A17/ 19  
 8A17/ 32  
 8A17/ 38  
 Verwendung für: /  
 applicable for:  
 FORD  
 MAZDA  
 VOLVO

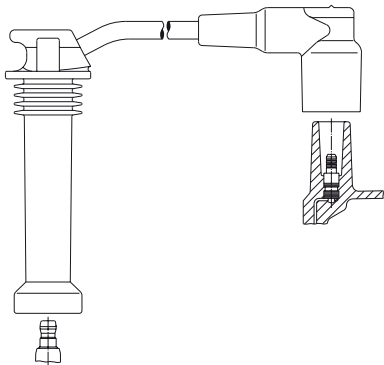

8A19/ 12  
 8A19/ 26  
 8A19/ 32  
 8A19/ 46  
 Verwendung für: /  
 applicable for:  
 FORD  
 MAZDA

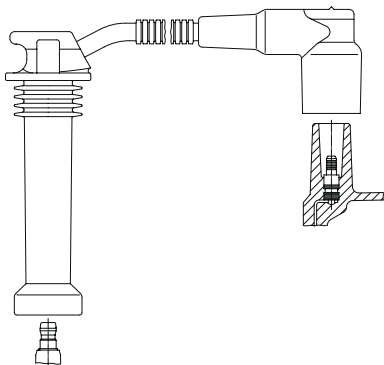

8A19E 33  
 Verwendung für: /  
 applicable for:  
 FORD



810/ 50  
 810/ 60  
 810/ 70  
 810/ 80  
 Verwendung für: /  
 applicable for:  
 FORD

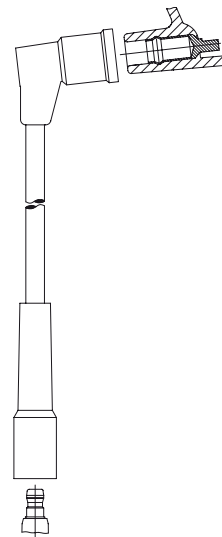

811/ 50  
 811/ 60  
 811/ 70  
 Verwendung für: /  
 applicable for:  
 FORD

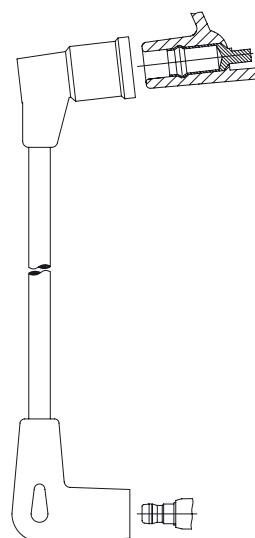

812/ 50  
 812/ 60  
 812/ 70  
 Verwendung für: /  
 applicable for:  
 FORD

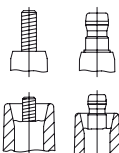

Connection spark plug: M4, SAE



Connection distributor cap: M4, SAE

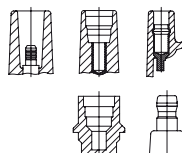

Connection distr. cap/ign. coil: 4 mm, Toyota 5 mm, DIN



Connection distr. cap/ign. coil: Ford, SAE

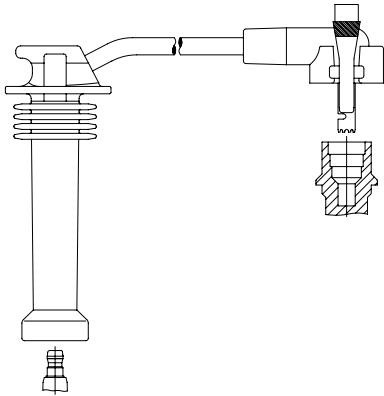

813/ 15  
813/ 30  
813/ 40  
813/ 45  
Verwendung für: /  
applicable for:  
FORD

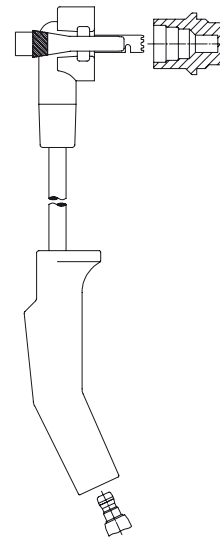

816/ 75  
816/ 80  
816/ 88  
816/100  
Verwendung für: /  
applicable for:  
FORD

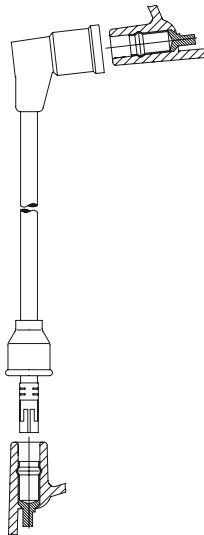

814/ 30  
814/ 40  
814/ 45  
814/ 50  
814/ 60  
814/ 70  
Verwendung für: /  
applicable for:  
FORD

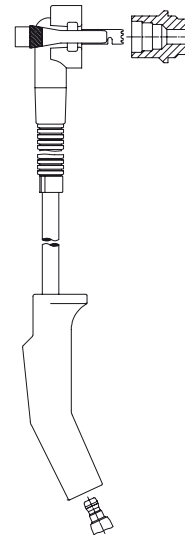

816E 85  
816E 95  
816E100  
Verwendung für: /  
applicable for:  
FORD

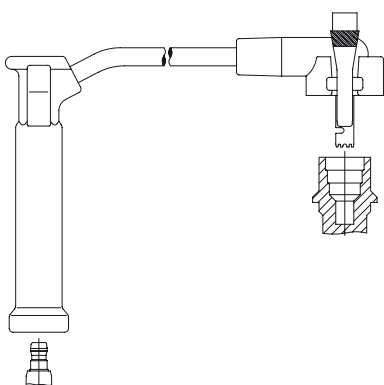

815/ 15  
815/ 20  
815/ 35  
815/ 40  
Verwendung für: /  
applicable for:  
FORD  
MAZDA

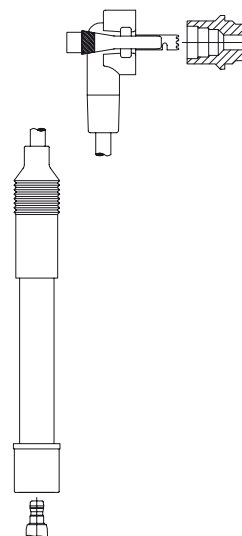

817/ 52  
817/ 59  
817/ 85  
817/ 90  
Verwendung für: /  
applicable for:  
FORD

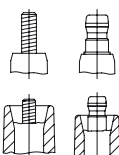

Connection spark plug: M4, SAE

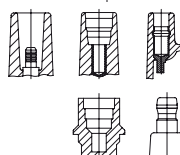

Connection distr. cap/ign. coil: 4 mm, Toyota 5 mm, DIN



Connection distributor cap: M4, SAE



Connection distr. cap/ign. coil: Ford, SAE

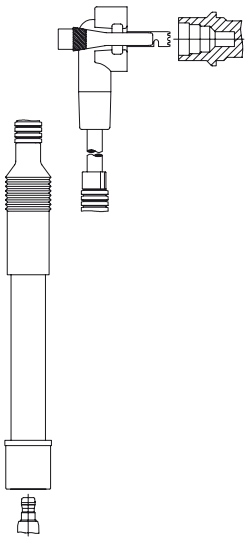

817E 60  
817E 70  
817E 72  
817E 84  
Verwendung für: /  
applicable for:  
FORD

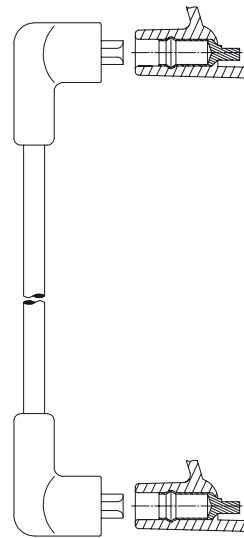

820/ 35  
820/ 57  
820/ 66  
820/ 73  
Verwendung für: /  
applicable for:  
FORD

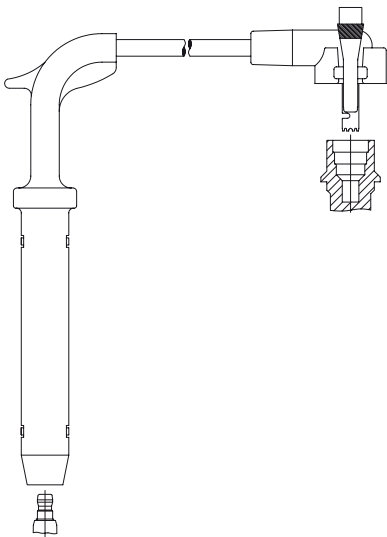

818/ 45  
818/ 50  
818/ 65  
818/ 78  
Verwendung für: /  
applicable for:  
FORD

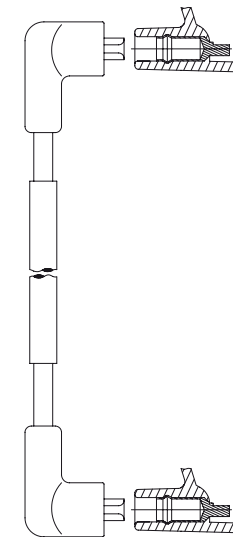

820E 50  
Verwendung für: /  
applicable for:  
FORD

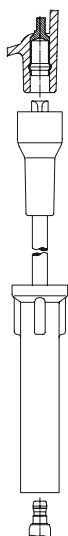

819/ 60  
819/ 65  
819/ 77  
819/ 82  
Verwendung für: /  
applicable for:  
FORD

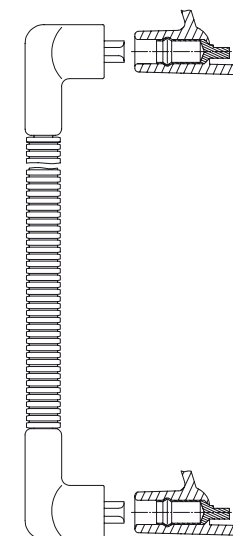

820J 83  
Verwendung für: /  
applicable for:  
FORD

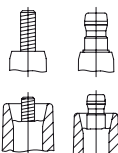

Connection spark plug: M4, SAE

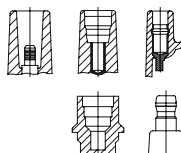

Connection distr. cap/ign. coil: 4 mm, Toyota 5 mm, DIN

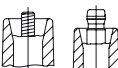

Connection distributor cap: M4, SAE



Connection distr. cap/ign. coil: Ford, SAE



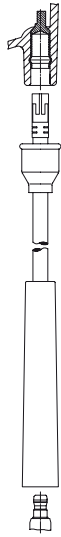

823/ 50  
823/ 60  
823/ 65  
823/ 70  
823/ 75  
823/ 82  
823/ 90  
Verwendung für: /  
applicable for:  
FORD

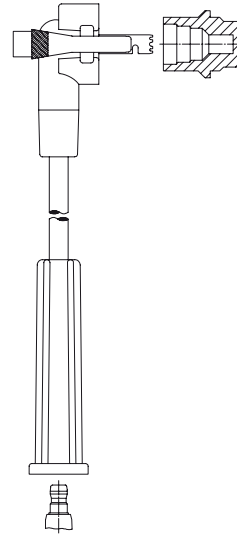

860/ 60  
860/ 65  
860/ 75  
860/ 76  
860/ 78  
860/ 80  
860/ 85  
860/ 92  
860/100  
Verwendung für: /  
applicable for:  
FORD

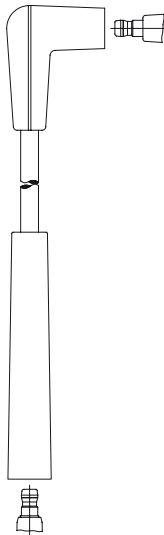

824/ 48  
824/ 50  
824/ 53  
824/ 57  
824/ 60  
824/ 70  
824/ 72  
824/ 80  
824/ 84  
Verwendung für: /  
applicable for:  
FORD

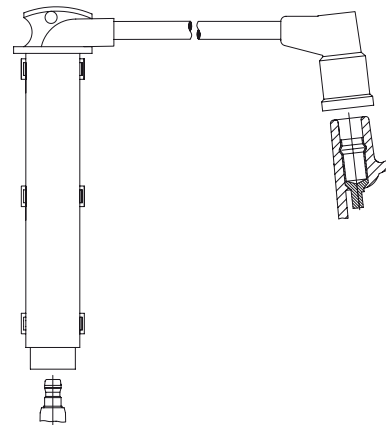

861/ 30  
861/ 40  
861/ 55  
861/ 60  
Verwendung für: /  
applicable for:  
FORD



825/ 59  
825/ 64  
825/ 74  
825/ 84  
Verwendung für: /  
applicable for:  
FORD

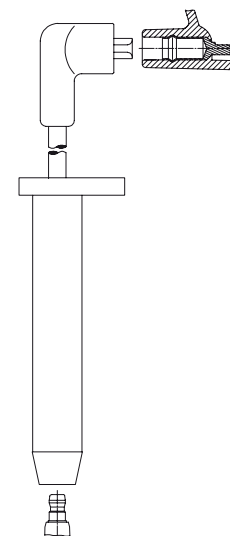

876/ 43  
876/ 49  
876/ 53  
876/ 63  
876/ 73  
Verwendung für: /  
applicable for:  
FORD

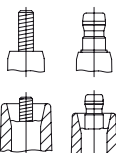

Connection spark plug: M4, SAE

Connection distributor cap: M4, SAE

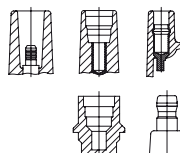

Connection distr. cap/ign. coil: 4 mm, Toyota 5 mm, DIN

Connection distr. cap/ign. coil: Ford, SAE

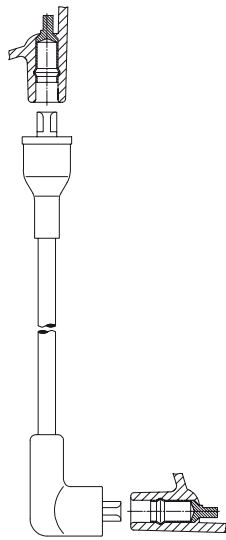

884/ 37  
884/ 45  
884/ 50  
884/ 60  
884/ 78  
Verwendung für: /  
applicable for:  
FORD

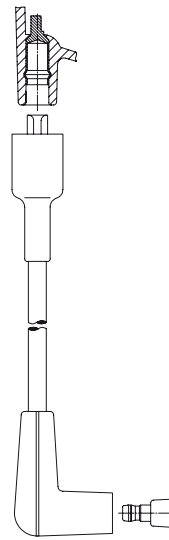

887/ 63  
Verwendung für: /  
applicable for:  
FORD

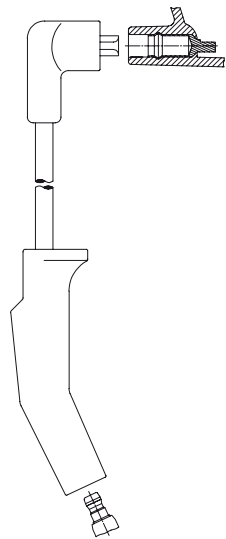

885/ 45  
885/ 48  
885/ 59  
885/ 62  
885/ 64  
885/ 69  
885/ 72  
885/ 75  
Verwendung für: /  
applicable for:  
FORD

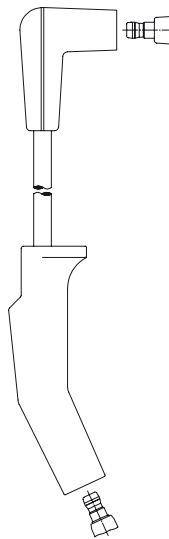

888/ 45  
888/ 47  
888/ 52  
888/ 56  
888/ 60  
888/ 72  
888/ 74  
Verwendung für: /  
applicable for:  
FORD

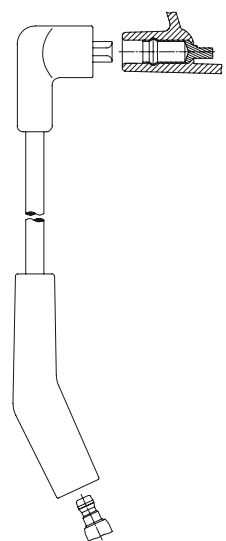

886/ 44  
886/ 61  
886/ 64  
Verwendung für: /  
applicable for:  
FORD

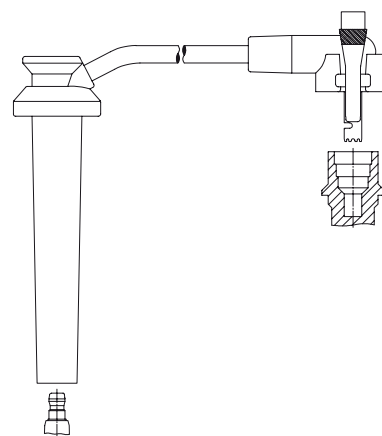

891/ 29  
891/ 79  
891/ 95  
Verwendung für: /  
applicable for:  
FORD

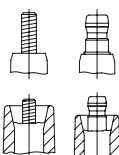

Connection spark plug: M4, SAE

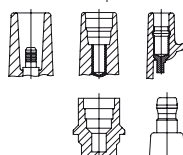

Connection distr. cap/ign. coil: 4 mm, Toyota 5 mm, DIN



Connection distributor cap: M4, SAE



Connection distr. cap/ign. coil: Ford, SAE

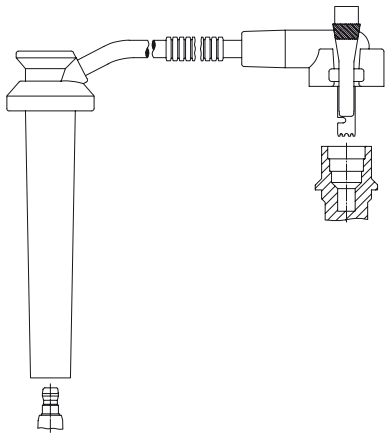

891E 35  
891E 38  
891E102  
Verwendung für: /  
applicable for:  
FORD

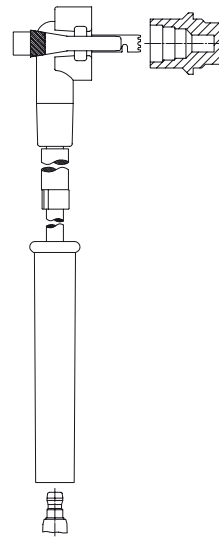

893E 80  
893E 82  
893E 90  
893E100  
Verwendung für: /  
applicable for:  
FORD



892/ 56  
Verwendung für: /  
applicable for:  
FORD

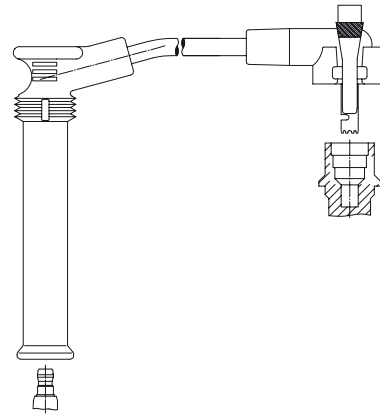

894/ 22  
894/ 31  
894/ 37  
894/ 40  
894/ 45  
894/ 51  
894/ 58  
894/ 61  
894/ 70  
894/ 82  
894/ 89  
Verwendung für: /  
applicable for:  
FORD

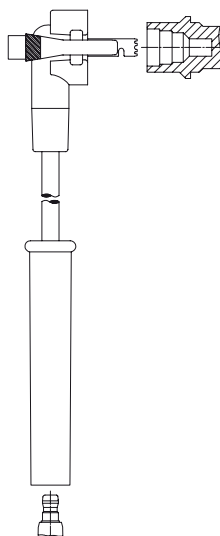

893/ 44  
893/ 53  
893/ 69  
893/ 80  
Verwendung für: /  
applicable for:  
FORD

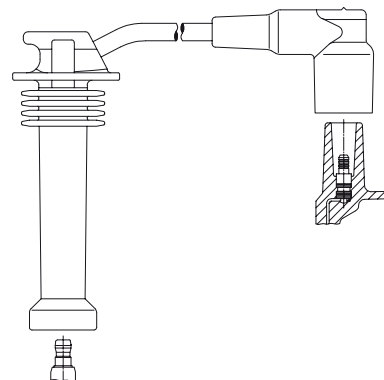

897/ 14  
897/ 28  
897/ 37  
897/ 43  
Verwendung für: /  
applicable for:  
FORD  
MAZDA

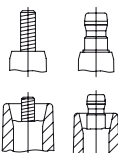

Connection spark plug: M4, SAE

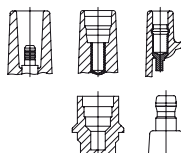

Connection distr. cap/ign. coil: 4 mm, Toyota 5 mm, DIN

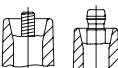

Connection distributor cap: M4, SAE



Connection distr. cap/ign. coil: Ford, SAE

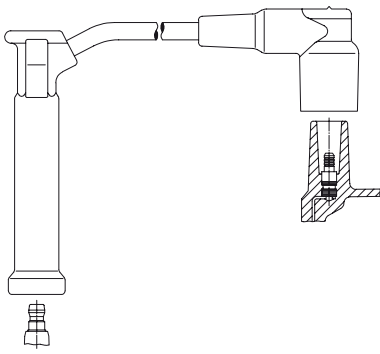

898/ 14  
 898/ 18  
 898/ 32  
 898/ 37  
 Verwendung für: /  
 applicable for:  
 FORD

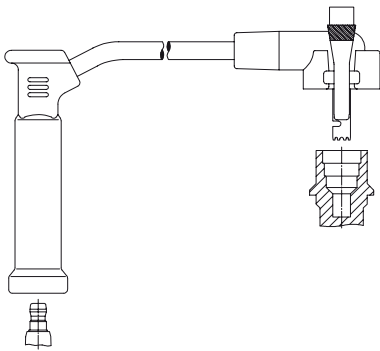

899/ 37  
 899/ 42  
 899/ 44  
 899/ 70  
 899/ 79  
 899/ 82  
 Verwendung für: /  
 applicable for:  
 FORD

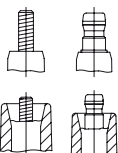

Connection spark plug: M4, SAE

Connection distributor cap: M4, SAE

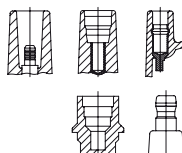

Connection distr. cap/ign. coil: 4 mm, Toyota 5 mm, DIN

Connection distr. cap/ign. coil: Ford, SAE

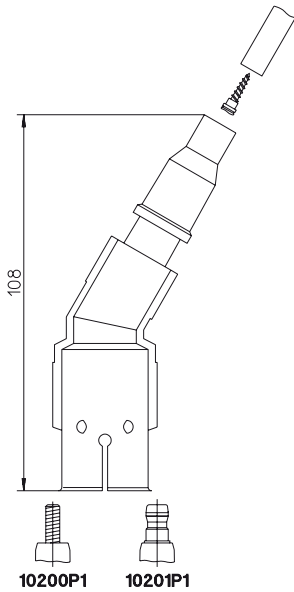

**10201P1**

Polyester/Polyester  
teilgeschirmt/partly screened  
1000 Ohm entstört/suppressed  
Wasserdicht/Waterproof  
21 mm Schlüsselweite/spanner

Verwendung für: / applicable for:  
ALFA ROMEO  
FORD  
PEUGOET  
OPEL  
VAUXHALL

**10208/1**

Epoxydharz/Epoxy resin  
1000 Ohm entstört/suppressed

Verwendung für: / applicable for:  
BMW

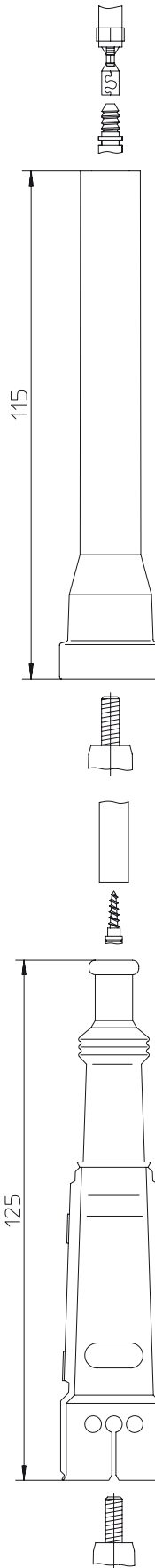
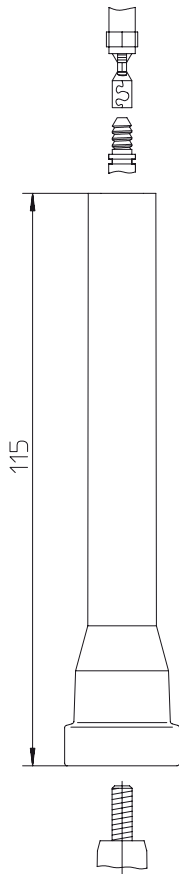

**10208/5**

Epoxydharz/Epoxy resin  
5000 Ohm entstört/suppressed

Verwendung für: / applicable for:  
BMW

**10210/5**

Polyester/Polyester  
Silikon/Silicone  
Teilschirmung aus Nirostablech/  
partly screened, stainless steel  
5000 Ohm entstört/suppressed  
Wasserdicht/Waterproof  
21 mm Schlüsselweite/spanner

Verwendung für: / applicable for:  
AUDI  
VW

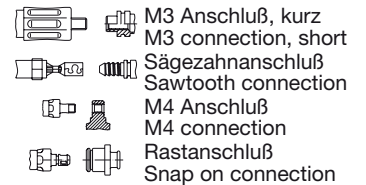
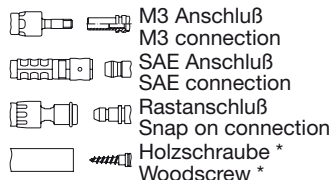
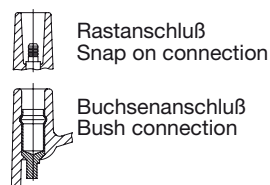
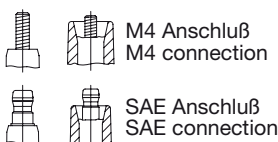
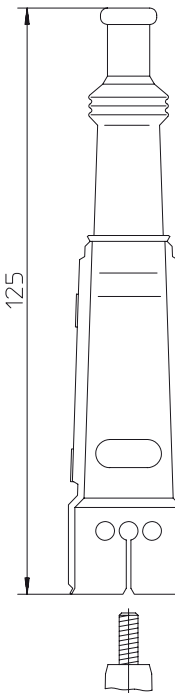

\* Holzschraube für Kat nicht geeignet  
\* Woodscrew not for suitable for kat



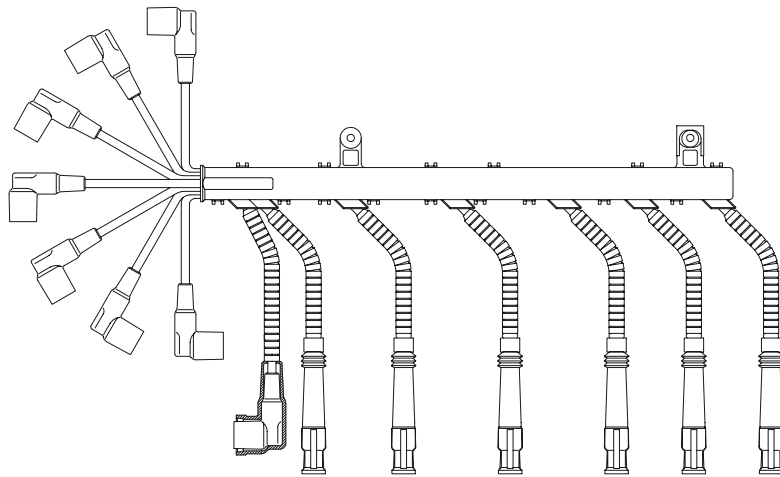

**238L100**

Anschlußtechnik:  
Sort of connection:



Verwendung für: / applicable for:  
BMW  
ROLLS-ROYCE

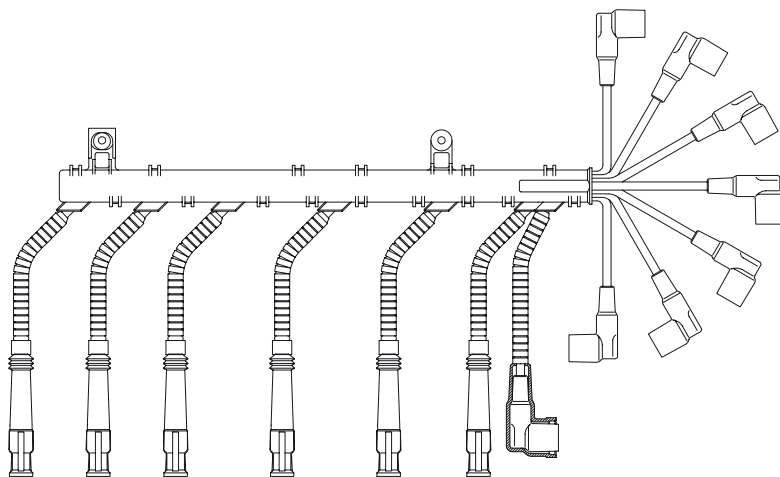

**238R100**

Anschlußtechnik:  
Sort of connection:



Verwendung für: / applicable for:  
BMW  
ROLLS-ROYCE

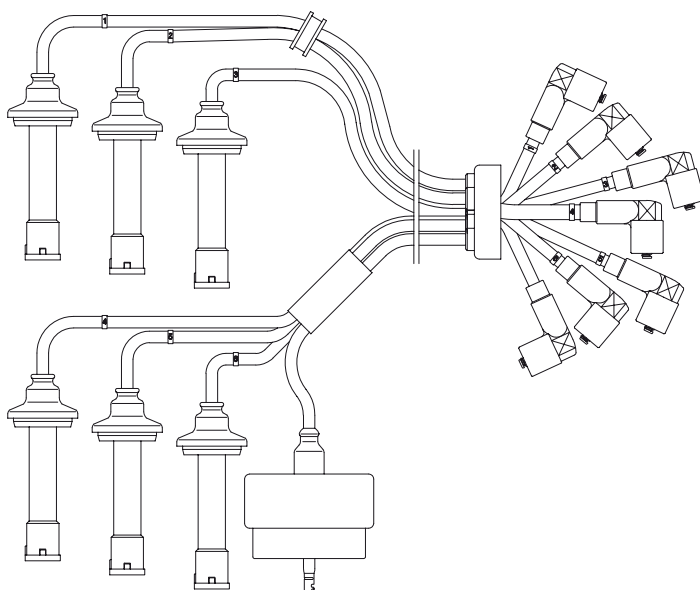

**243**

Anschlußtechnik:  
Sort of connection:



Verwendung für: / applicable for:  
ALFA ROMEO



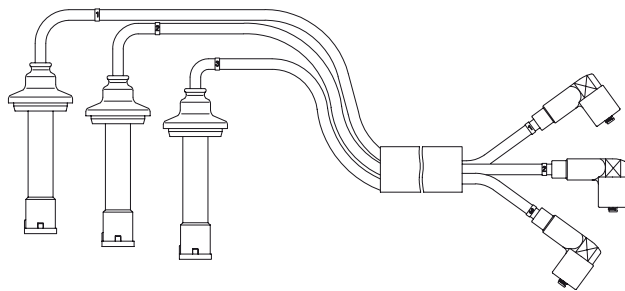

**244**

Anschlußtechnik:  
Sort of connection:



Verwendung für: / applicable for:  
ALFA ROMEO

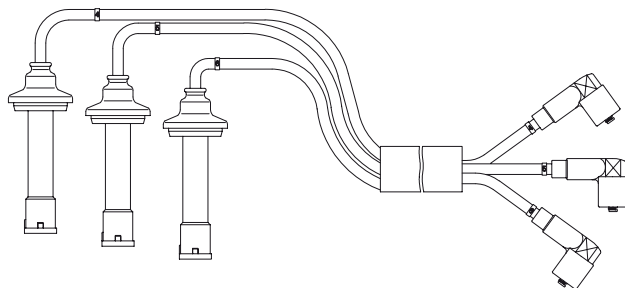

**246L100**

Anschlußtechnik:  
Sort of connection:



Verwendung für: / applicable for:  
BMW

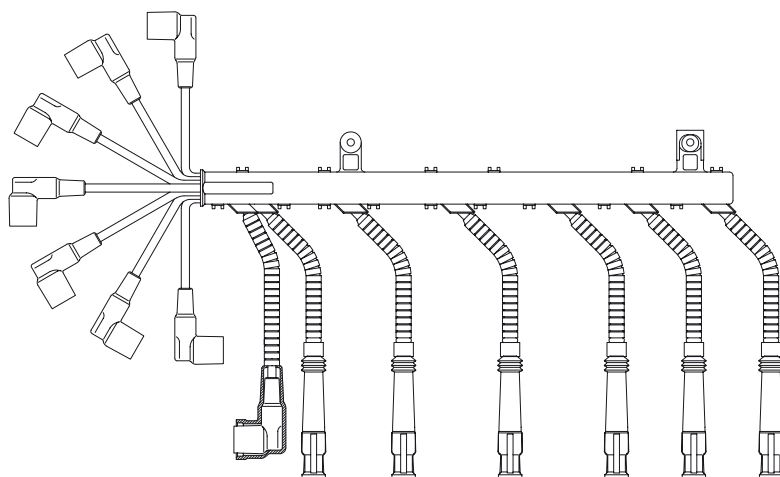

**246R100**

Anschlußtechnik:  
Sort of connection:



Verwendung für: / applicable for:  
BMW

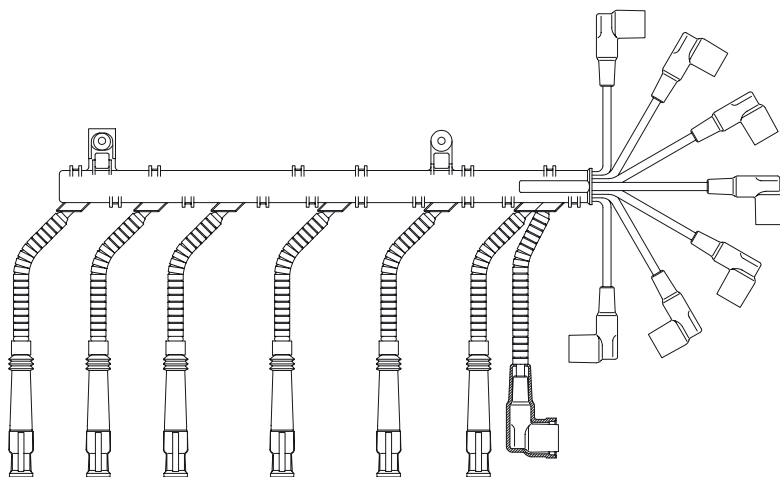

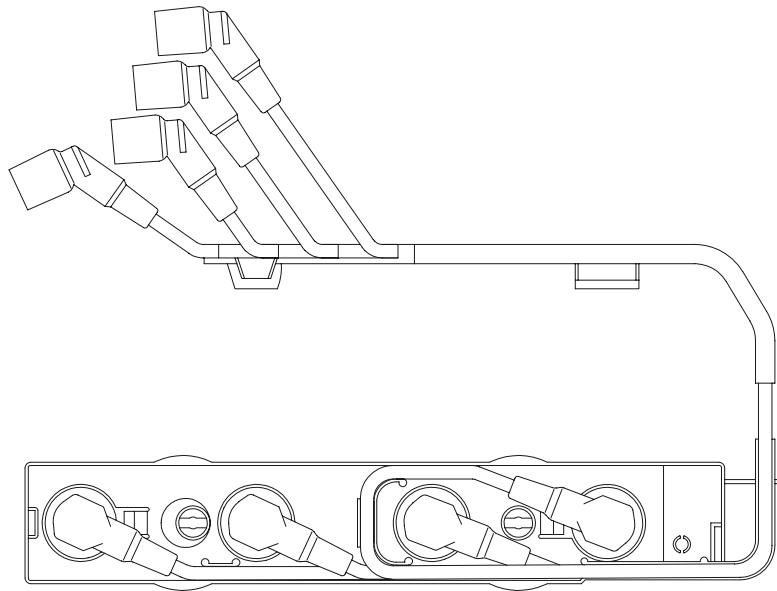

**281/100**

Anschlußtechnik:  
Sort of connection:



Verwendung für: / applicable for:  
BMW

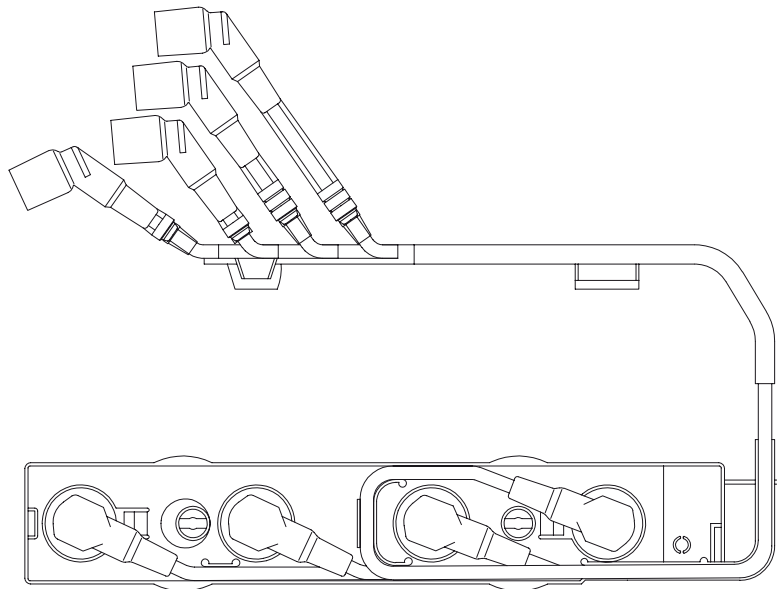

**281S100**

Anschlußtechnik:  
Sort of connection:



Verwendung für: / applicable for:  
BMW

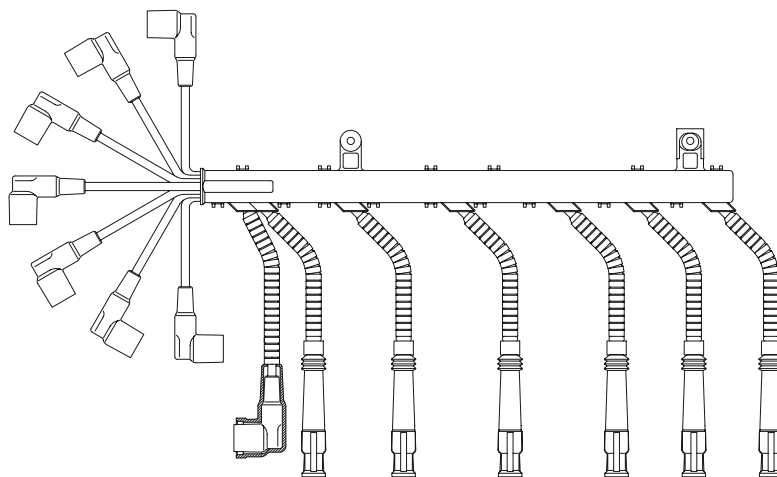

**284L100**

Anschlußtechnik:  
Sort of connection:



Verwendung für: / applicable for:  
BMW



**284R100**

Anschlußtechnik:  
Sort of connection:



Verwendung für: / applicable for:  
BMW

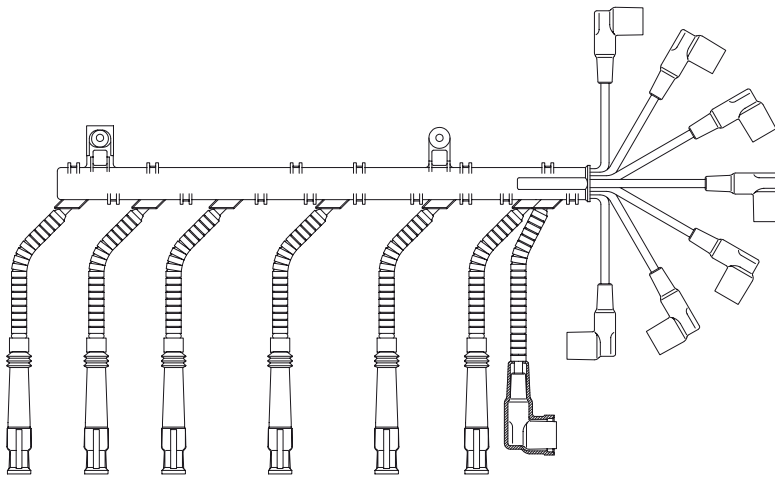

**300/673**

Anschlußtechnik:  
Sort of connection:



Verwendung für: / applicable for:  
HOLDEN  
OPEL

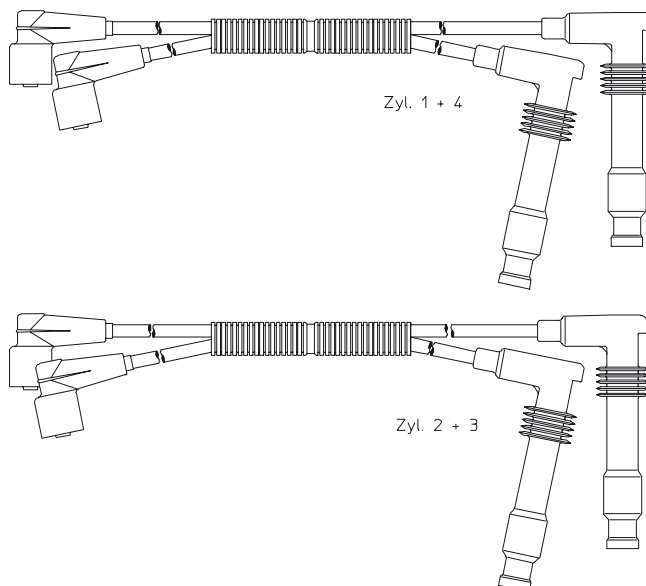

**300/674**

Anschlußtechnik:  
Sort of connection:



Verwendung für: / applicable for:  
OPEL  
VAUXHALL

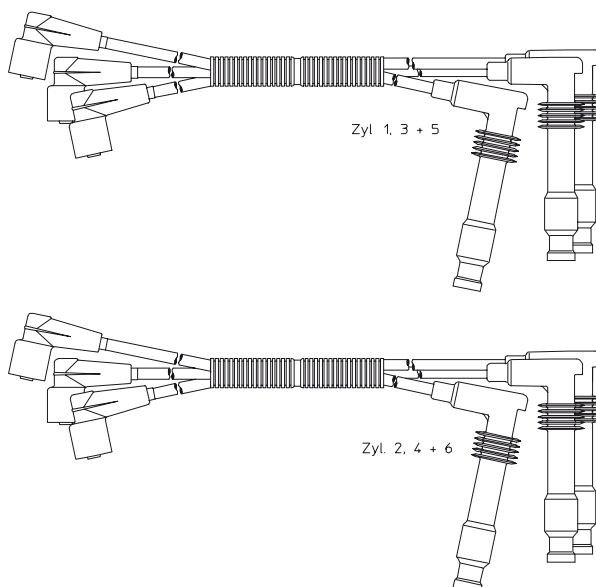

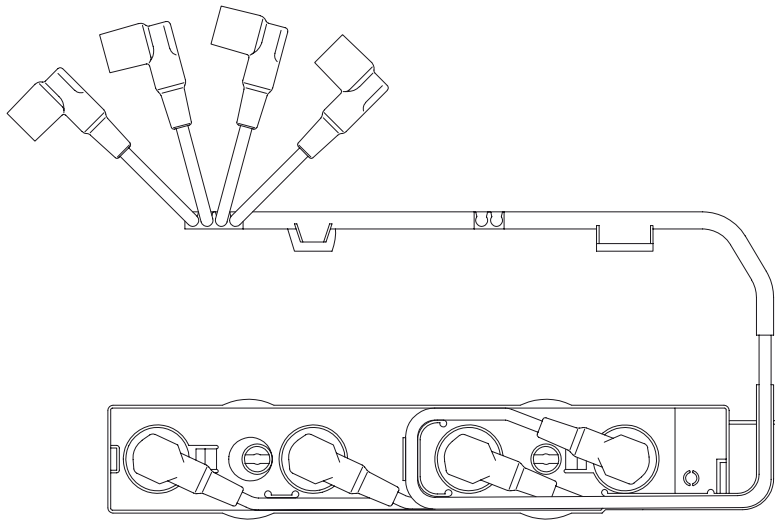

440/100

Anschlußtechnik:  
Sort of connection:



Verwendung für: / applicable for:  
BMW

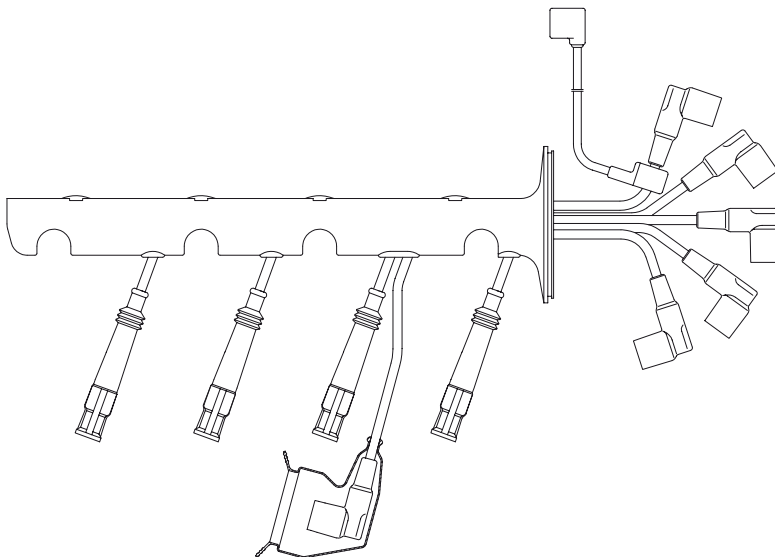

464/100

Anschlußtechnik:  
Sort of connection:



Verwendung für: / applicable for:  
BMW

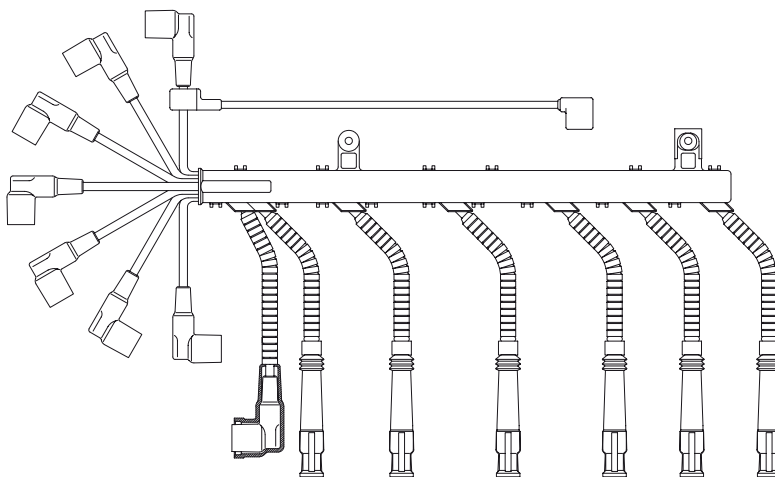

465L100

Anschlußtechnik:  
Sort of connection:



Verwendung für: / applicable for:  
BMW

**465R100**

Anschlußtechnik:  
Sort of connection:



Verwendung für: / applicable for:  
BMW

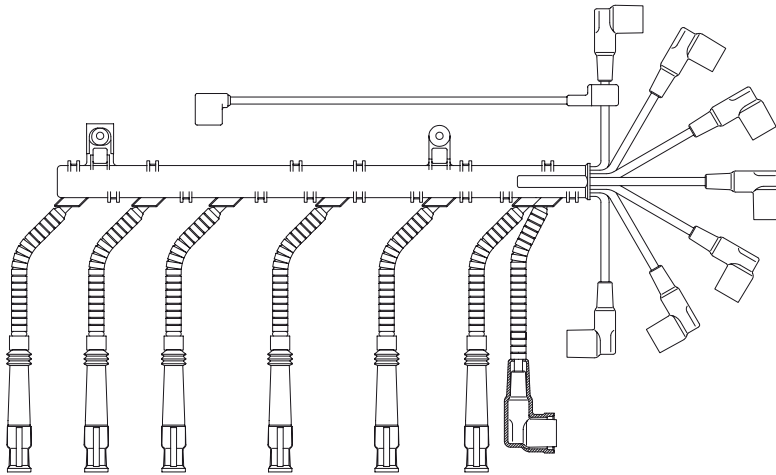

**473/100**

Anschlußtechnik:  
Sort of connection:



Verwendung für: / applicable for:  
SEAT  
VW

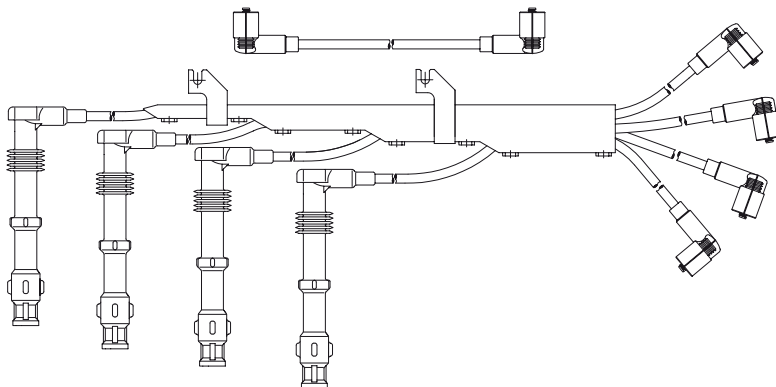

**503A100**

Anschlußtechnik:  
Sort of connection:



Verwendung für: / applicable for:  
BMW

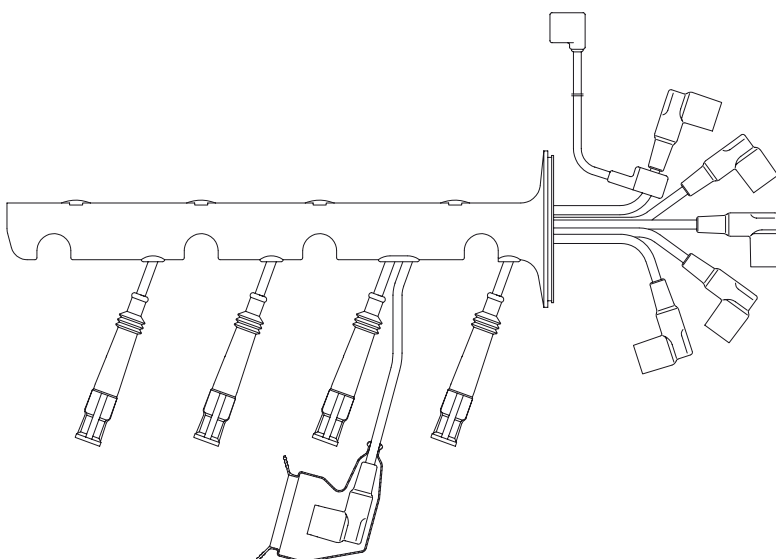

517/100

Anschlußtechnik:  
Sort of connection:



Verwendung für: / applicable for:  
BMW

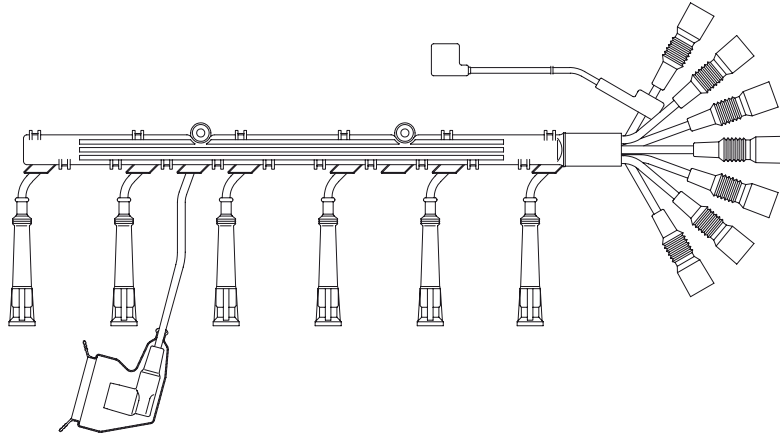

520/100

Anschlußtechnik:  
Sort of connection:



Verwendung für: / applicable for:  
BMW

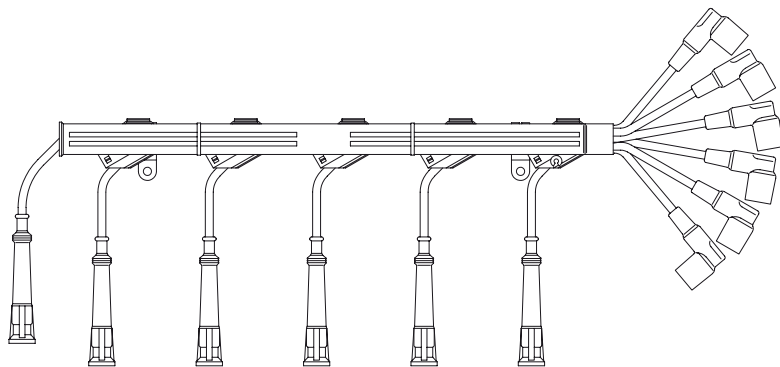

525/100

Anschlußtechnik:  
Sort of connection:



Verwendung für: / applicable for:  
BMW

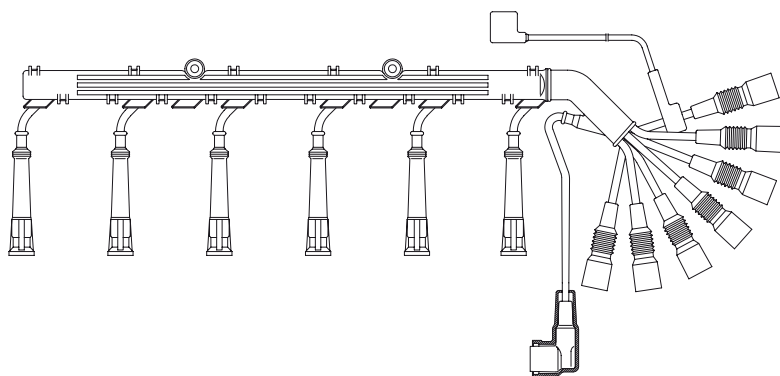

**537/100**

Anschlußtechnik:  
Sort of connection:



Verwendung für: / applicable for:  
BMW

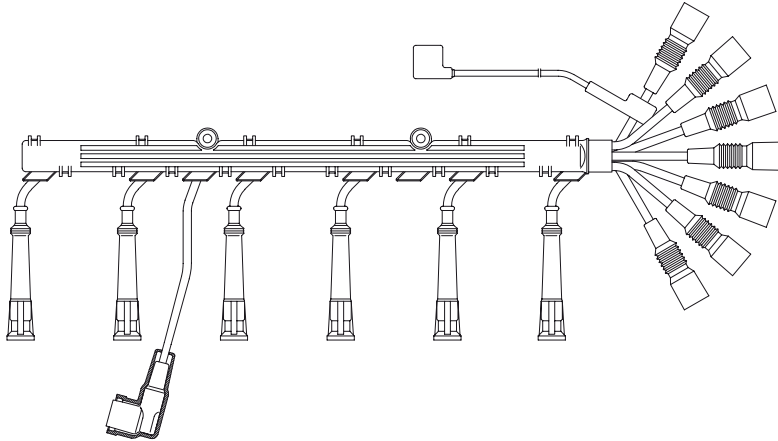

**538/100**

Anschlußtechnik:  
Sort of connection:



Verwendung für: / applicable for:  
BMW

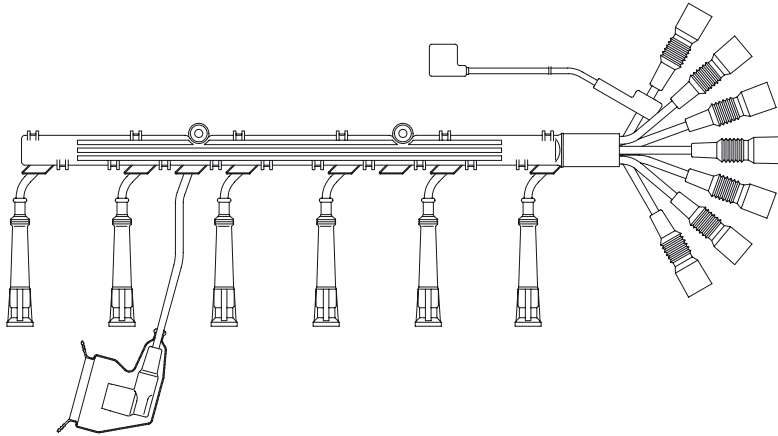

**546/100**

Anschlußtechnik:  
Sort of connection:



Verwendung für: / applicable for:  
BMW

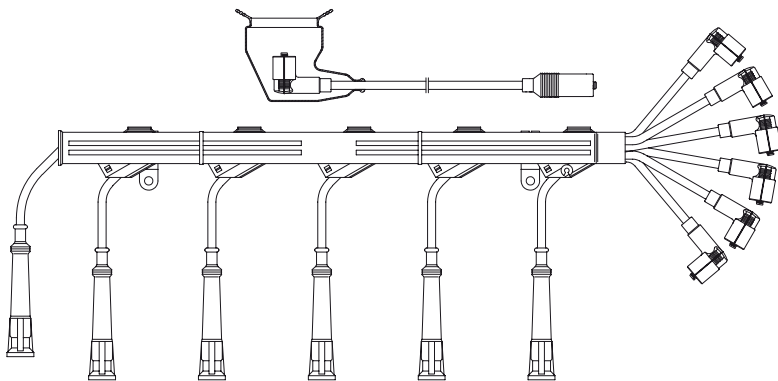

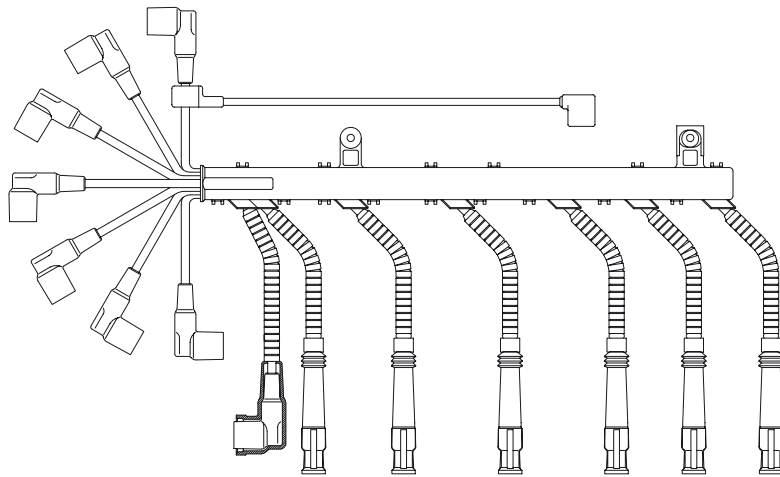

**552L100**

Anschlußtechnik:  
Sort of connection:



Verwendung für: / applicable for:  
BMW

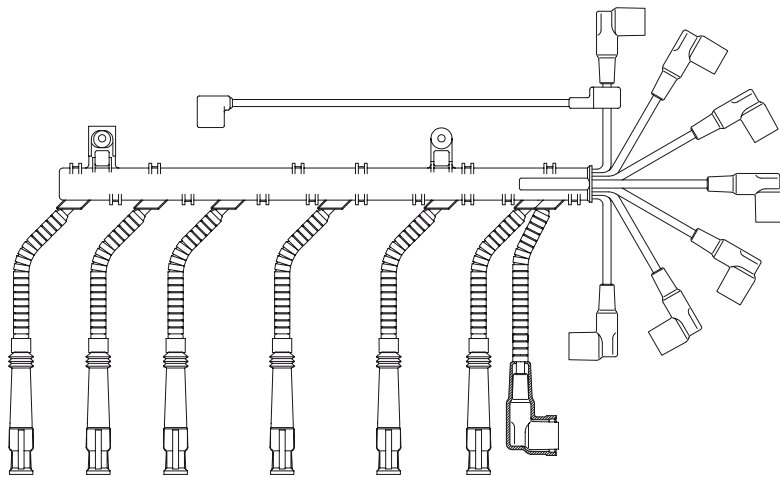

**552R100**

Anschlußtechnik:  
Sort of connection:



Verwendung für: / applicable for:  
BMW

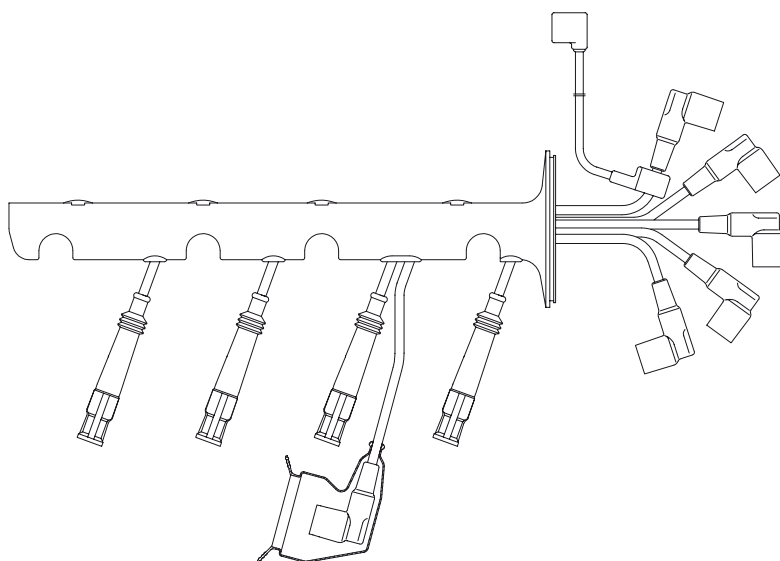

**569/100**

Anschlußtechnik:  
Sort of connection:



Verwendung für: / applicable for:  
BMW

**571/100**

Anschlußtechnik:  
Sort of connection:



Verwendung für: / applicable for:  
BMW

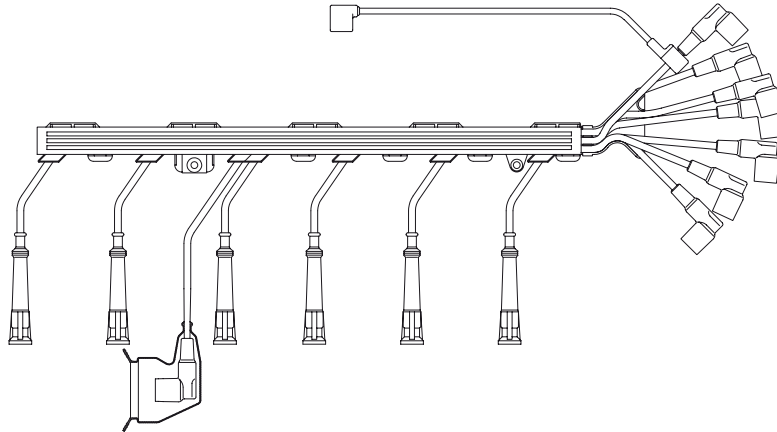

**571A100**

Anschlußtechnik:  
Sort of connection:



Verwendung für: / applicable for:  
BMW

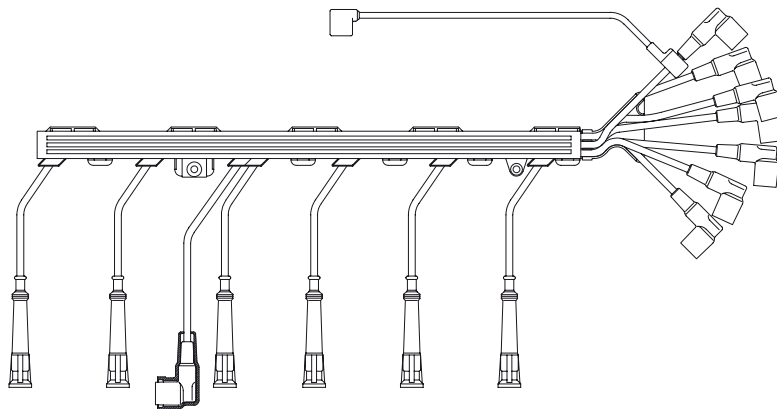

**573/100**

Anschlußtechnik:  
Sort of connection:



Verwendung für: / applicable for:  
BMW

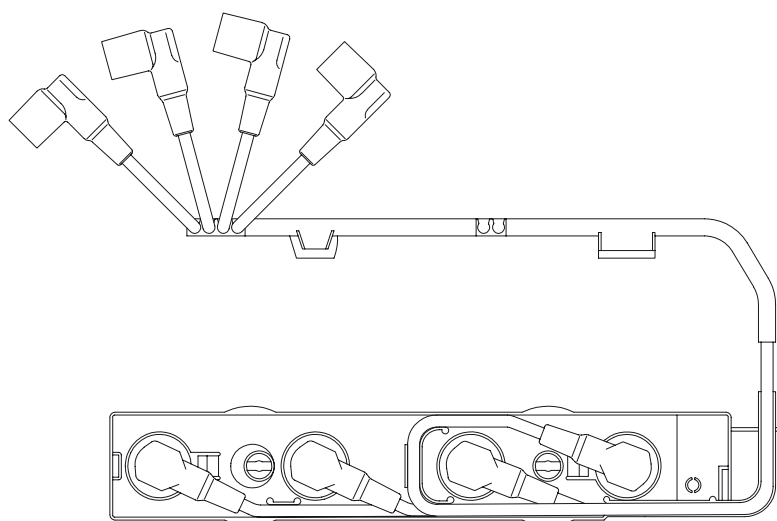

**574L100**

Anschlußtechnik:  
Sort of connection:



Verwendung für: / applicable for:  
BMW

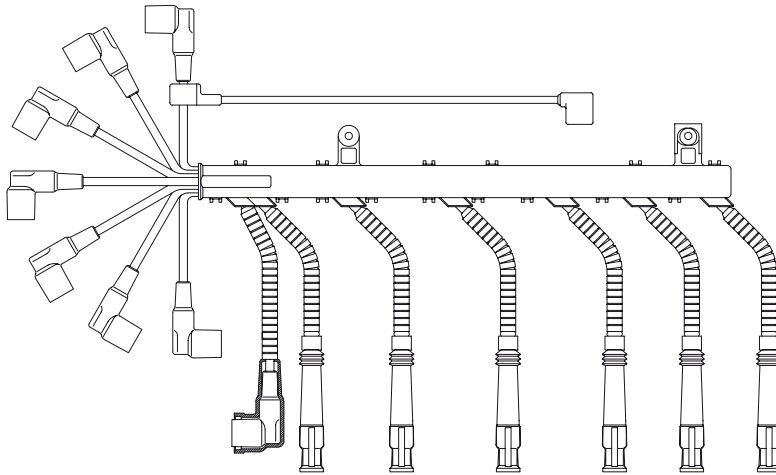

**574R100**

Anschlußtechnik:  
Sort of connection:



Verwendung für: / applicable for:  
BMW

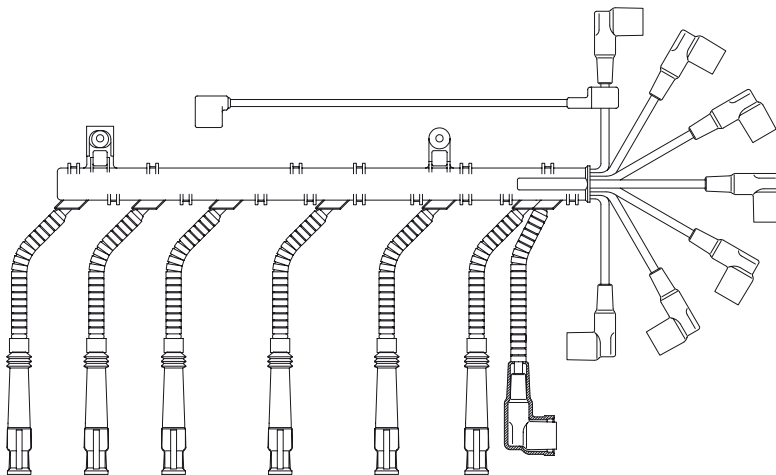

**582/100**

Anschlußtechnik:  
Sort of connection:



Verwendung für: / applicable for:  
BMW

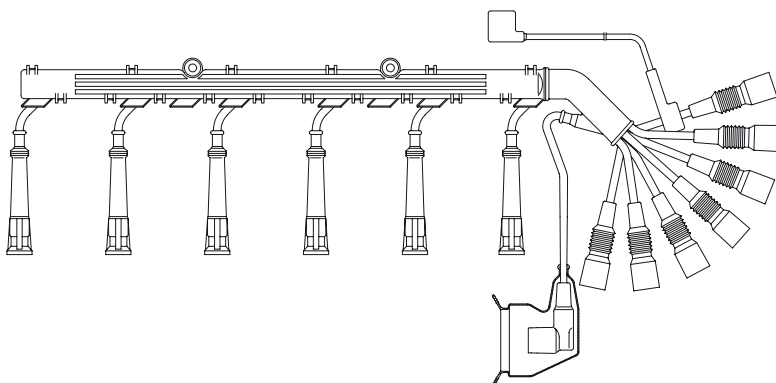



583/100

Anschlußtechnik:  
Sort of connection:



Verwendung für: / applicable for:  
BMW

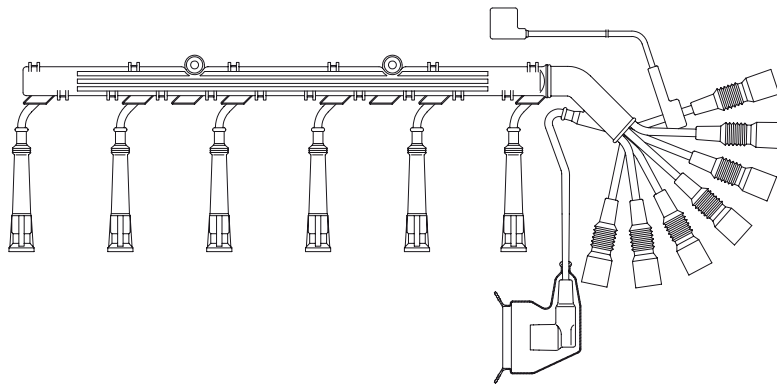

706/100

Anschlußtechnik:  
Sort of connection:



Verwendung für: / applicable for:  
BMW

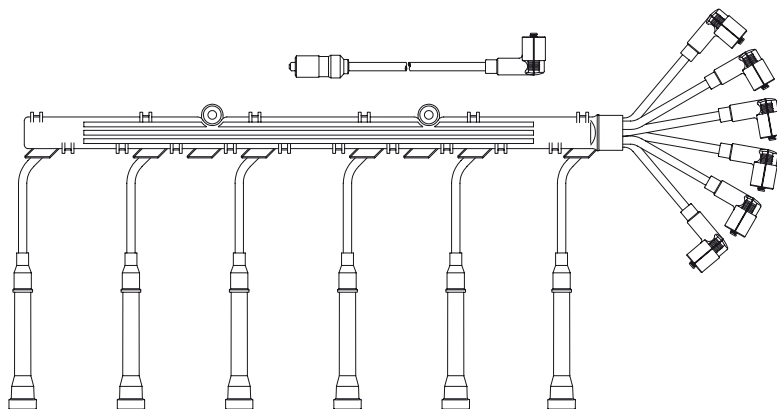

780/100

Anschlußtechnik:  
Sort of connection:



Verwendung für: / applicable for:  
BMW

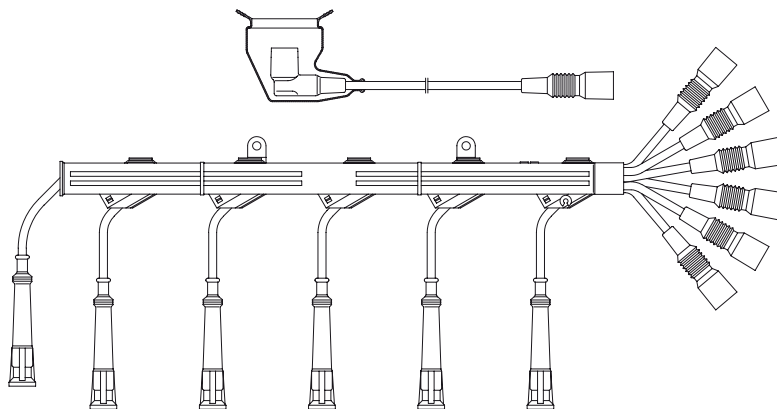

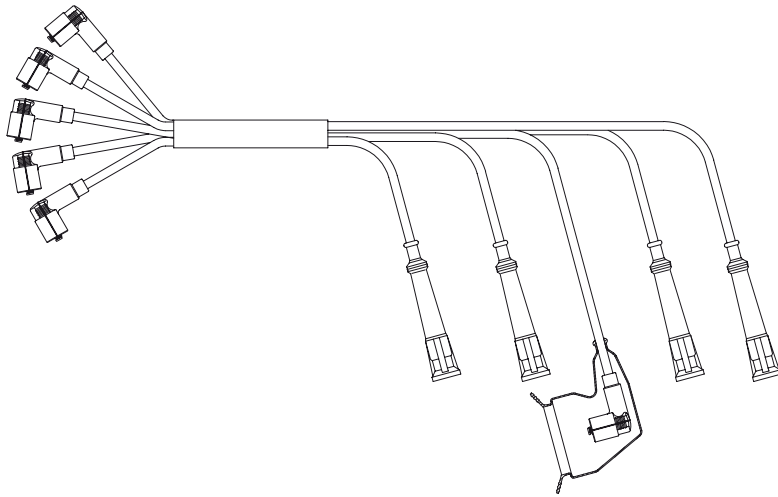

**782/100**

Anschlußtechnik:  
Sort of connection:



Verwendung für: / applicable for:  
BMW

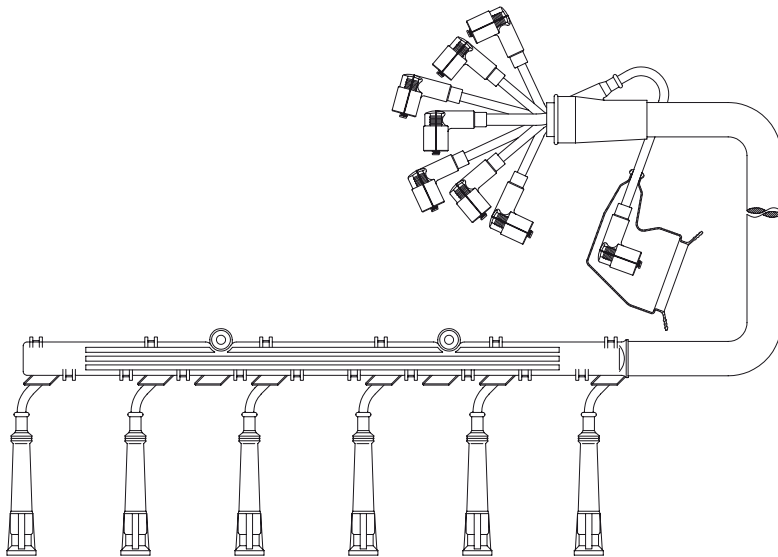

**784A100**

Anschlußtechnik:  
Sort of connection:



Verwendung für: / applicable for:  
BMW

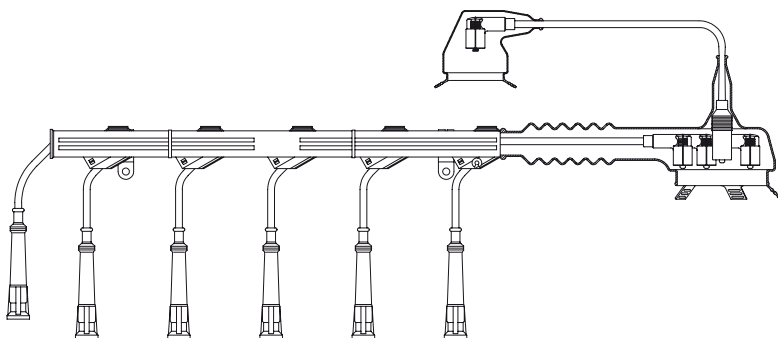

**786/100**

Anschlußtechnik:  
Sort of connection:



Verwendung für: / applicable for:  
BMW

**923/100**

Anschlußtechnik:  
Sort of connection:



Verwendung für: / applicable for:  
SEAT  
SKODA  
VW

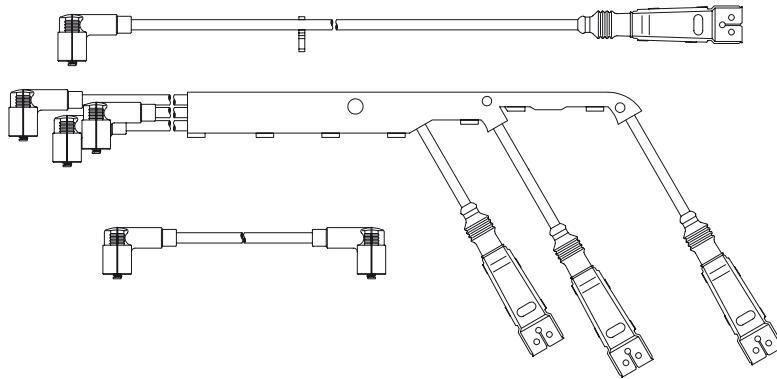

**968E100**

Anschlußtechnik:  
Sort of connection:



Verwendung für: / applicable for:  
SEAT  
VW

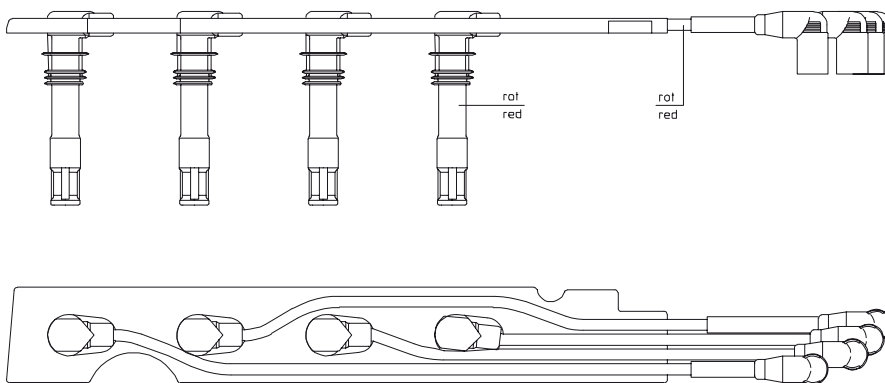

**968F100**

Anschlußtechnik:  
Sort of connection:



Verwendung für: / applicable for:  
VW

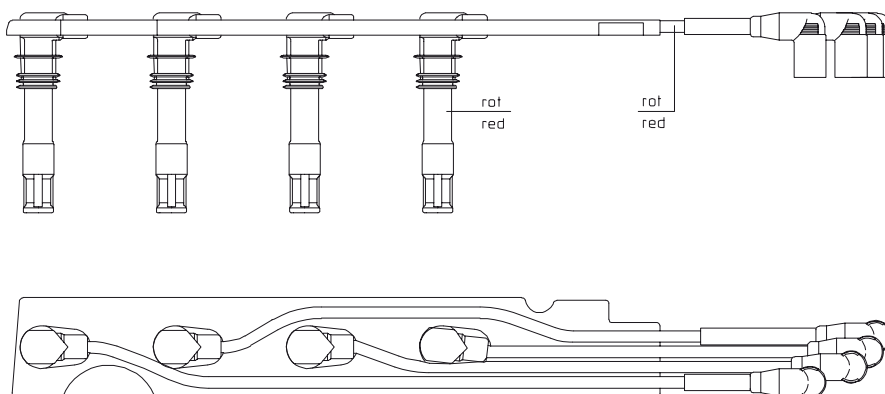

**968G100**

Anschlußtechnik:  
Sort of connection:

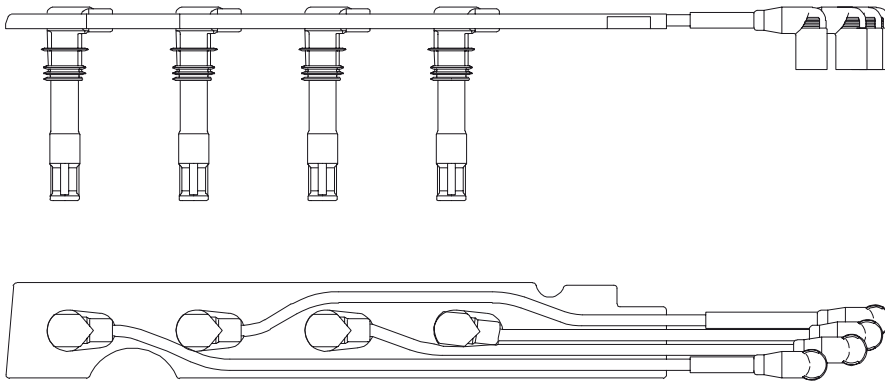

Verwendung für: / applicable for:

AUDI  
SEAT  
SKODA  
VW

**7A01/200**

Verwendung für: / applicable for:  
PORSCHE

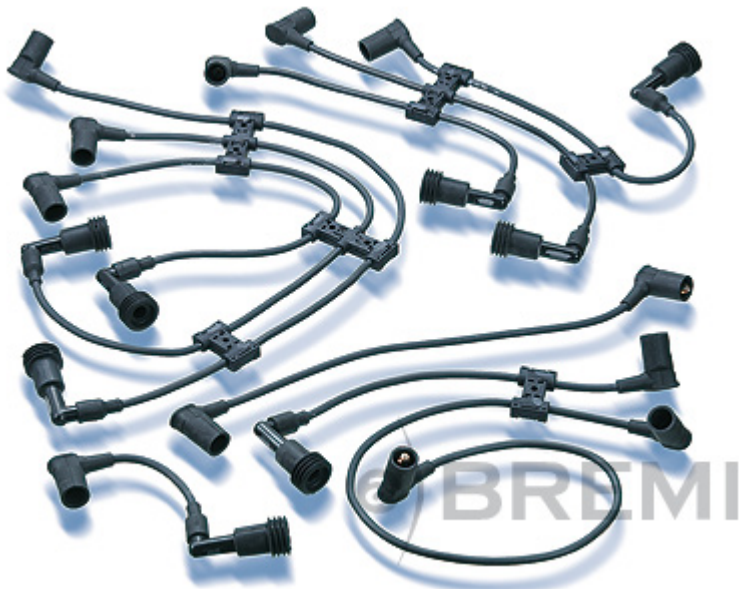

**7A02/200**

Verwendung für: / applicable for:  
PORSCHE

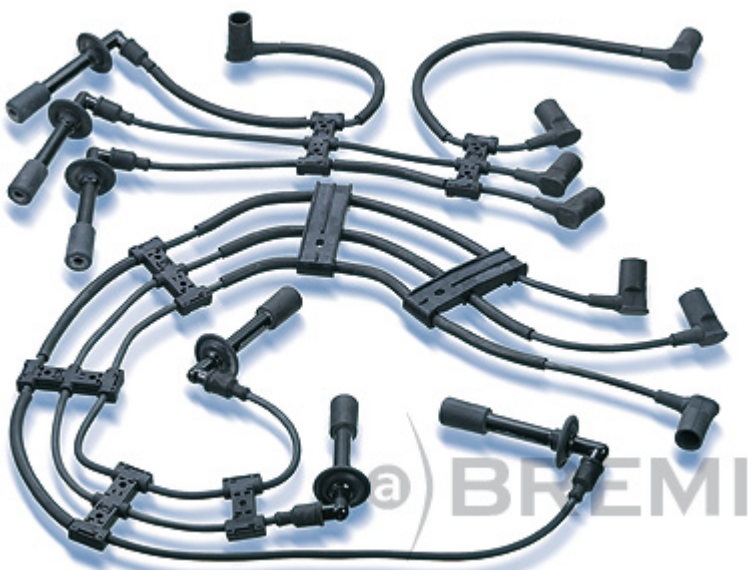



**7A03/200**

Verwendung für: / applicable for:  
PORSCHE

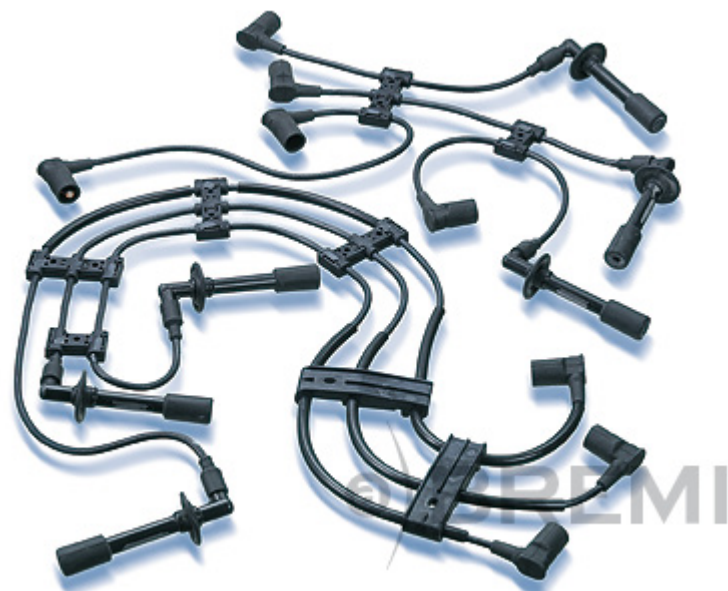

**7A04/200**

Verwendung für: / applicable for:  
PORSCHE

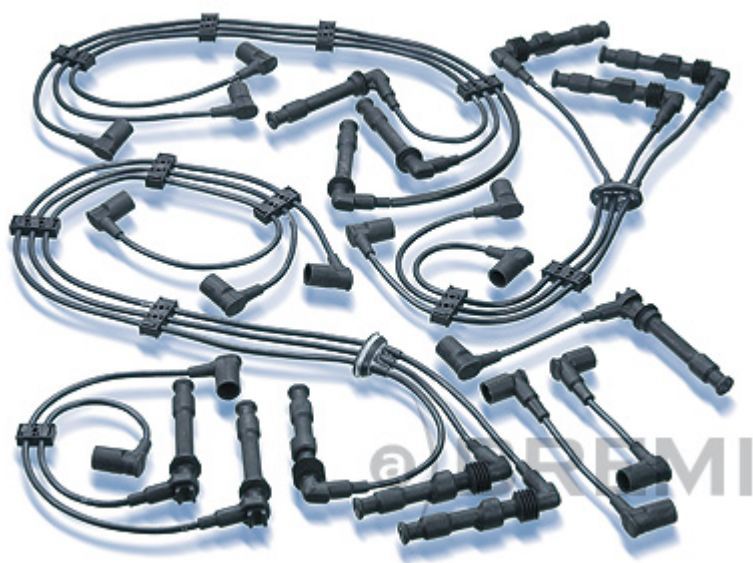

**7A05/200**

Verwendung für: / applicable for:  
PORSCHE



**7A06/200**

Verwendung für: / applicable for:  
PORSCHE

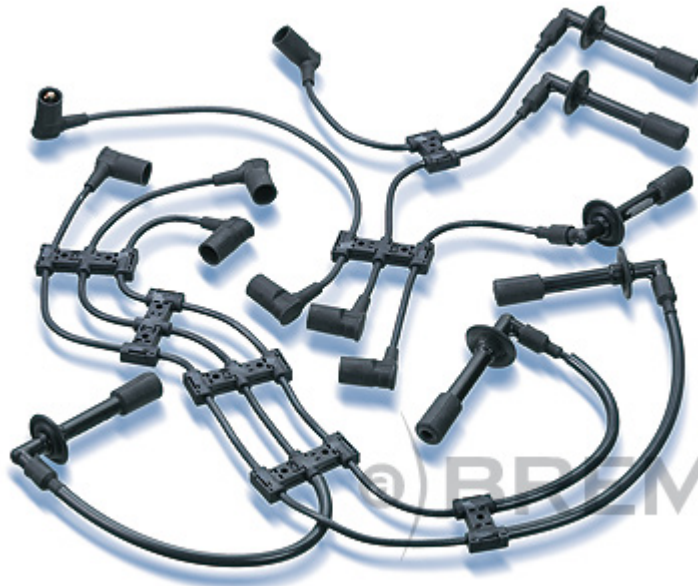

**7A07/200**

Verwendung für: / applicable for:  
PORSCHE



**7A08**

Verwendung für: / applicable for:  
PORSCHE



**7A09/100**

Verwendung für: / applicable for:  
PORSCHE



**7A10**

Verwendung für: / applicable for:  
PORSCHE



**7A11**

Verwendung für: / applicable for:  
PORSCHE



**7A12**

Verwendung für: / applicable for:  
PORSCHE

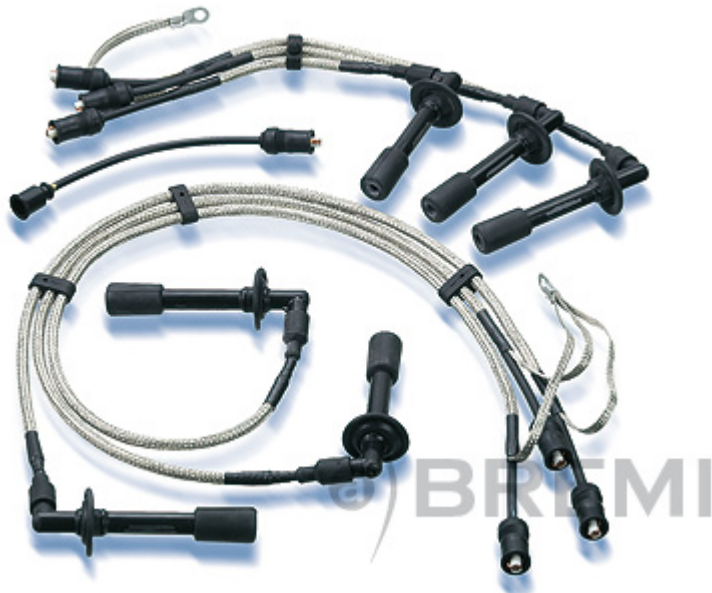

**7A13/200**

Verwendung für: / applicable for:  
PORSCHE

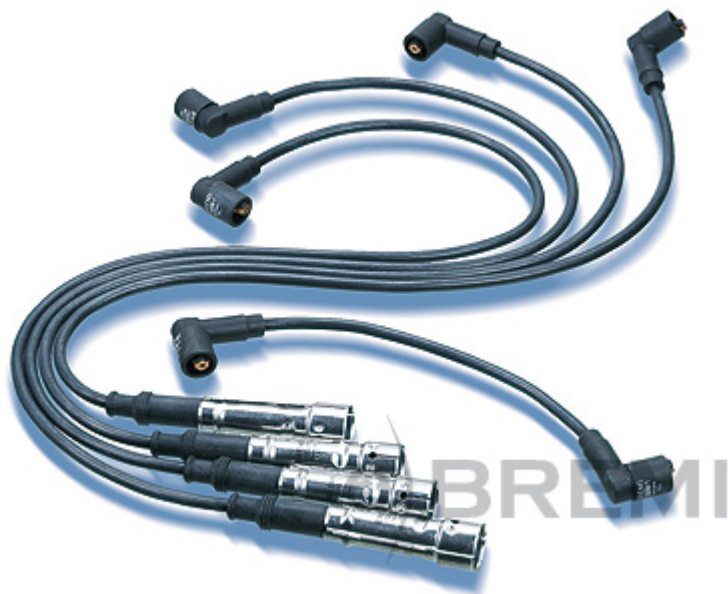

**7A14**

Verwendung für: / applicable for:  
PORSCHE



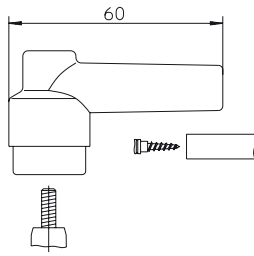

**10211**  
Isolierstoff/Insulating material  
Verwendung für: / applicable for:  
KLEINMOTORE  
SMALL MOTORS

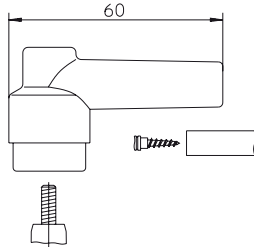

**10212/1**  
Isolierstoff/Insulating material  
1000 Ohm entstört/suppressed  
Verwendung für: / applicable for:  
MERCEDES-BENZ

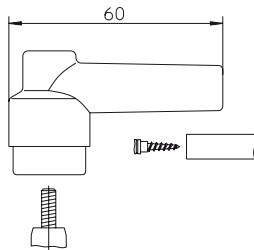

**10212/5**  
Isolierstoff/Insulating material  
5000 Ohm entstört/suppressed  
Verwendung für: / applicable for:  
MG

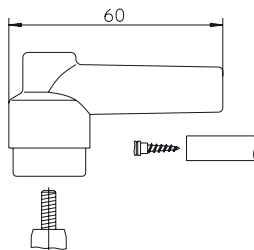

**10213/1**  
Isolierstoff/Insulating material  
1000 Ohm entstört/suppressed  
Verwendung für: / applicable for:  
AUSTIN  
FORD  
INNOCENTI

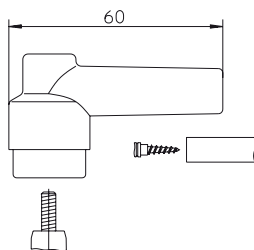

**10213/5**  
Isolierstoff/Insulating material  
5000 Ohm entstört/suppressed  
Verwendung für: / applicable for:  
DACIA  
FIAT  
FORD  
HONDA  
LANCIA  
MORRIS  
TALBOT

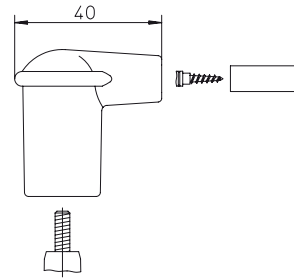

**10215**  
Für Zündkabel bis 7,5 mm/For  
ignition cables with 7.5 mm  
Isolierstoff/Insulating material  
Verwendung für: / applicable for:  
KLEINMOTORE  
SMALL MOTORS

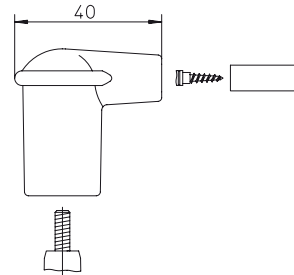

**10216**  
Für Zündkabel bis 5,5 mm/For  
ignition cables with 5.5 mm  
Isolierstoff/Insulating material  
Verwendung für: / applicable for:  
KLEINMOTORE  
SMALL MOTORS

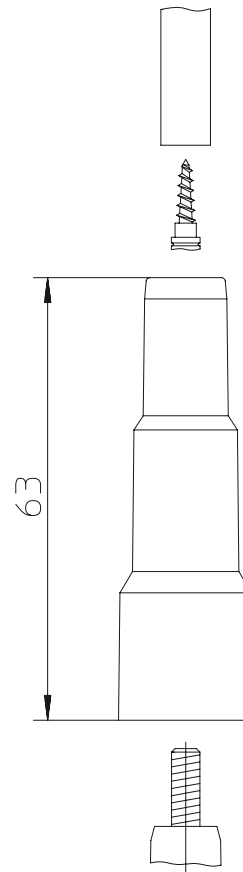

**10229N1**  
Isolierstoff/Insulating material  
1000 Ohm entstört/suppressed  
Verwendung für: / applicable for:  
VW

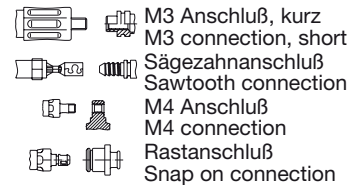
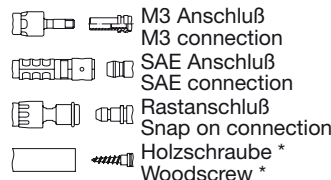
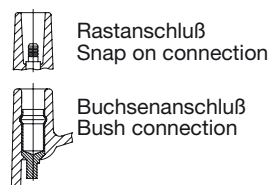
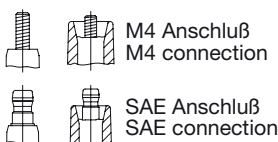

\* Holzschraube für Kat nicht geeignet  
\* Woodscrew not suitable for kat

**10229N10**

Isolierstoff/Insulating material  
10000 Ohm entstört/suppressed

Verwendung für: / applicable for:  
UNIVERSAL

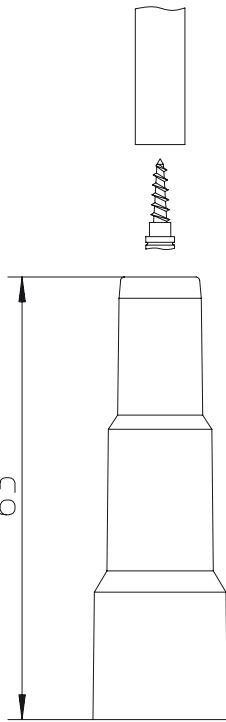

**10230N**

Isolierstoff/Insulating material

Verwendung für: / applicable for:  
UNIVERSAL

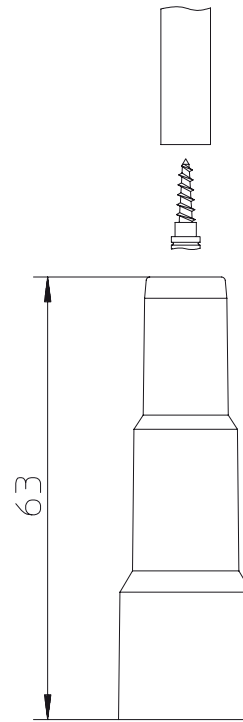

**10229N5**

Isolierstoff/Insulating material  
5000 Ohm entstört/suppressed

Verwendung für: / applicable for:  
UNIVERSAL

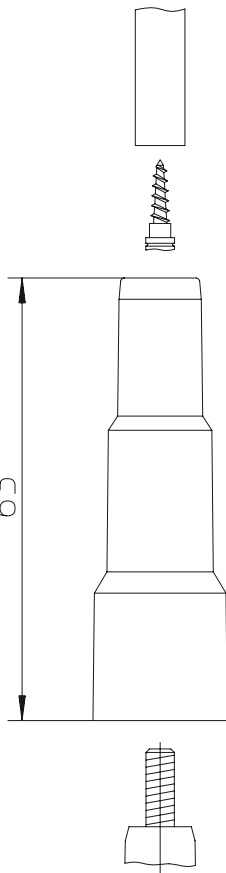

**10234/1,4**

Isolierstoff/Insulating material  
1000 Ohm entstört/suppressed

Verwendung für: / applicable for:  
BMW

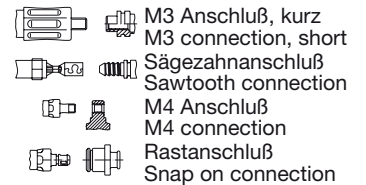
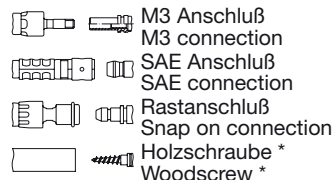
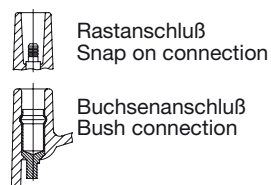
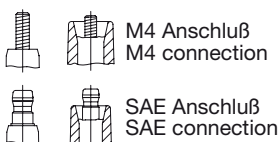
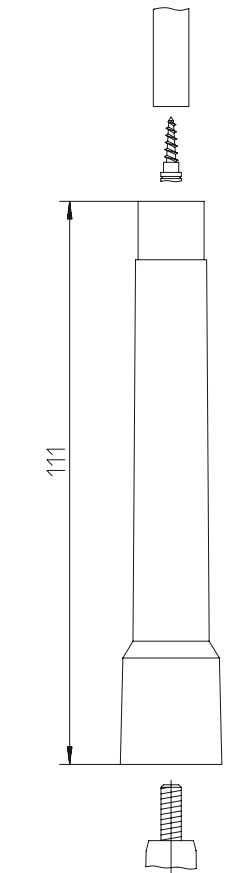

\* Holzschraube für Kat nicht geeignet  
\* Woodscrew not suitable for kat

**10234/5**

Isolierstoff/Insulating material  
5000 Ohm entstört/suppressed

Verwendung für: / applicable for:  
BMW

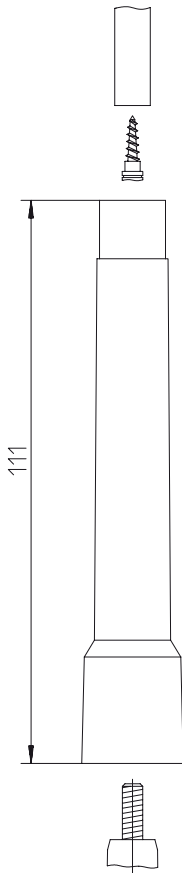

**10239/1**

Für Zündkabel bis 5,5 mm/For  
ignition cables with 5.5 mm  
Isolierstoff/Insulating material  
teilgeschirmt/partly screened  
1000 Ohm entstört/suppressed  
21 mm Schlüsselweite/spanner

Verwendung für: / applicable for:  
MOTORRÄDER

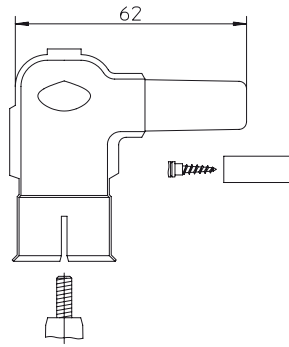

**10239H1**

Für Zündkabel bis 7,5 mm/For  
ignition cables with 7.5 mm  
Isolierstoff/Insulating material  
teilgeschirmt/partly screened  
1000 Ohm entstört/suppressed  
21 mm Schlüsselweite/spanner

Verwendung für: / applicable for:  
KLEINKRAFTRÄDER  
(hoher Zylinderkopf)

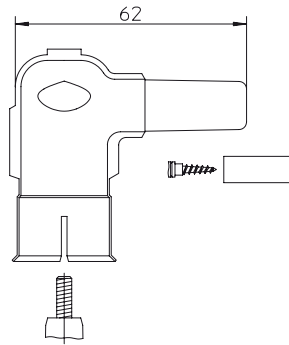

**10244/1**

Für Zündkabel bis 7,5 mm/For  
ignition cables with 7.5 mm  
Isolierstoff/Insulating material  
teilgeschirmt/partly screened  
1000 Ohm entstört/suppressed  
Wasserdicht/Waterproof  
21 mm Schlüsselweite/spanner

Verwendung für: / applicable for:  
FORD

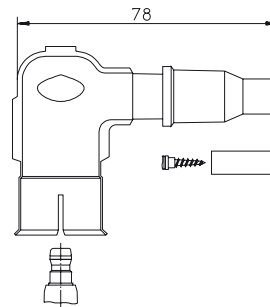

**10238/1**

Für Zündkabel bis 7,5 mm/For  
ignition cables with 7.5 mm  
Isolierstoff/Insulating material  
teilgeschirmt/partly screened  
1000 Ohm entstört/suppressed  
21 mm Schlüsselweite/spanner

Verwendung für: / applicable for:  
MOTORRÄDER  
WARTBURG  
TRABANT

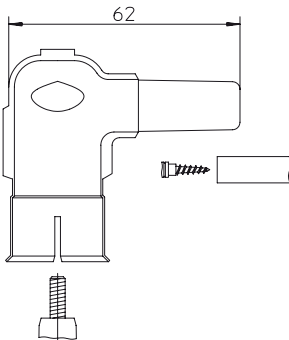

**10245/1**

Für Zündkabel bis 7,5 mm/For  
ignition cables with 7.5 mm  
Isolierstoff/Insulating material  
teilgeschirmt/partly screened  
1000 Ohm entstört/suppressed  
Wasserdicht/Waterproof  
21 mm Schlüsselweite/spanner

Verwendung für: / applicable for:  
MOTORRÄDER  
WARTBURG  
TRABANT

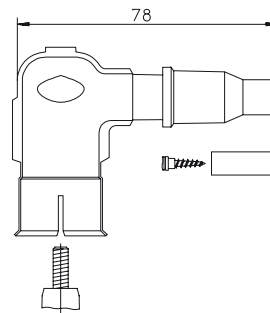

**10238/5**

Für Zündkabel bis 7,5 mm/For  
ignition cables with 7.5 mm  
Isolierstoff/Insulating material  
teilgeschirmt/partly screened  
5000 Ohm entstört/suppressed  
21 mm Schlüsselweite/spanner

Verwendung für: / applicable for:  
ALFA ROMEO

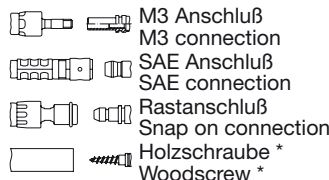
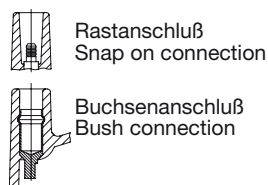
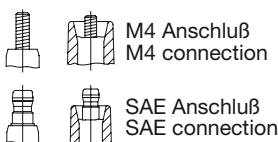
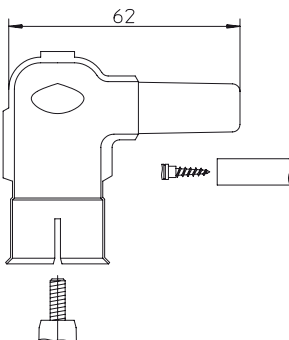

\* Holzschraube für Kat nicht geeignet  
\* Woodscrew not suitable for kat

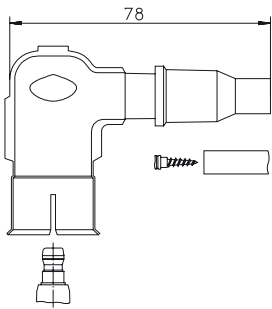

## 10246/1

Für Zündkabel bis 5,5 mm/For ignition cables with 5.5 mm  
Isolierstoff/Insulating material  
teilgeschirmt/partly screened  
1000 Ohm entstört/suppressed  
Wasserdicht/Waterproof  
21 mm Schlüsselweite/spanner

Verwendung für: / applicable for:  
MOTORRÄDER

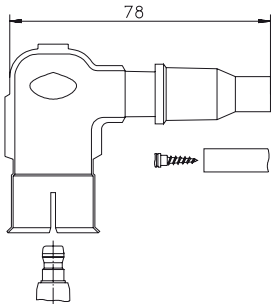

## 10246H1

Für Zündkabel bis 5,5 mm/For ignition cables with 5.5 mm  
Isolierstoff/Insulating material  
teilgeschirmt/partly screened  
1000 Ohm entstört/suppressed  
Wassergeschützt/Waterprotected  
21 mm Schlüsselweite/spanner

Verwendung für: / applicable for:  
KLEINKRAFTRÄDER  
(hoher Zylinderkopf)



## 10249N1

Isolierstoff/Insulating material  
1000 Ohm entstört/suppressed

Verwendung für: / applicable for:  
AUTOBIANCHI  
CITROEN  
DAF  
FIAT  
FORD  
HONDA  
LADA  
MAZDA  
MOSKVITCH  
SAAB  
SEAT

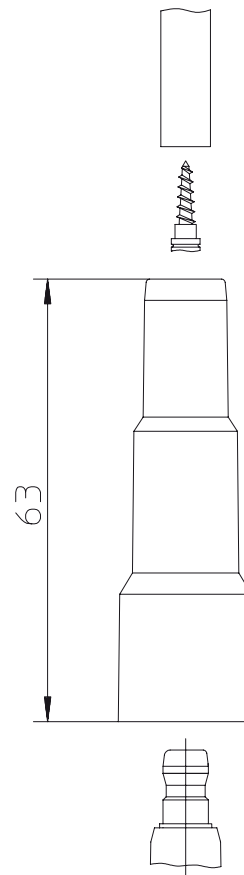
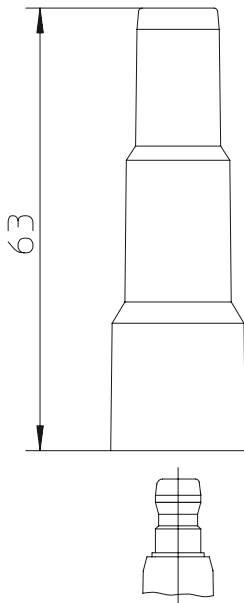

## 10249N5

Isolierstoff/Insulating material  
5000 Ohm entstört/suppressed

Verwendung für: / applicable for:  
RENAULT  
ROVER  
TALBOT

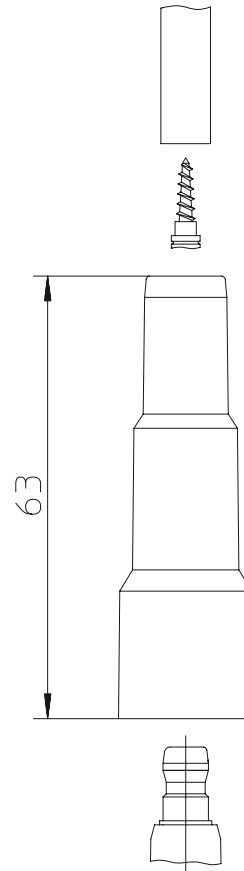

## 10274

Isolierstoff/Insulating material

Verwendung für: / applicable for:  
UNIVERSAL

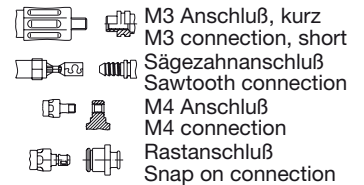
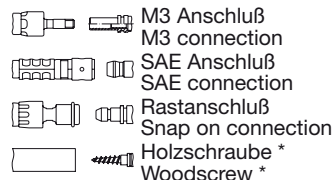
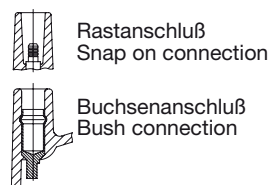
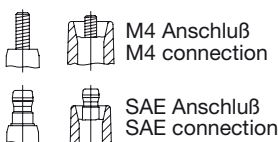

\* Holzschraube für Kat nicht geeignet  
\* Woodscrew not suitable for kat

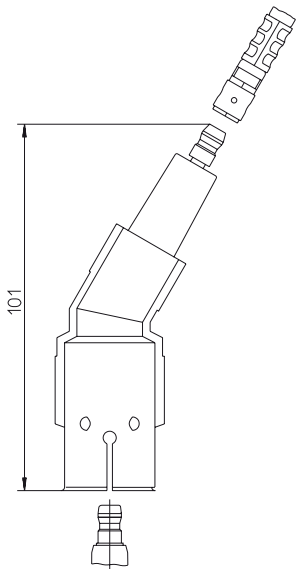

**10293**

Polyester/Polyester  
teilgeschirmt/partly screened  
Kerzenseitig wassergeschützt/Wa-  
ter protected to spark plug  
21 mm Schlüsselweite/spanner

Verwendung für: / applicable for:  
OPEL  
VAUXHALL

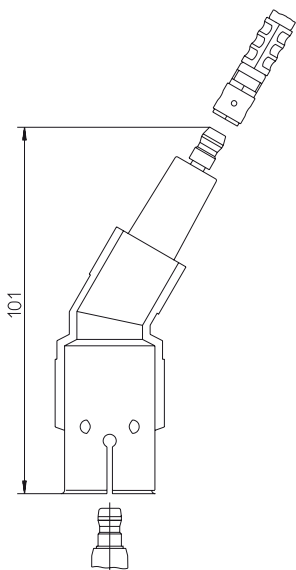

**10293P1**

Polyester/Polyester  
teilgeschirmt/partly screened  
1000 Ohm entstört/suppressed  
Kerzenseitig wassergeschützt/Wa-  
ter protected to spark plug  
21 mm Schlüsselweite/spanner

Verwendung für: / applicable for:  
FORD  
OPEL  
PEUGEOT  
RELIANT  
VAUXHALL

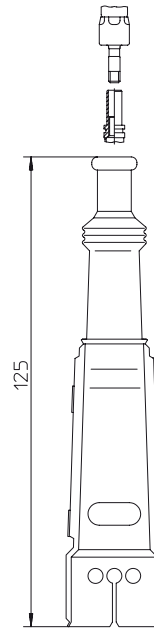

**13202/1**

Epoxydharz/Epoxy resin  
Silikon/Silicone  
Teilschirmung aus Nirostablech/  
partly screened, stainless steel  
1000 Ohm entstört/suppressed  
Wasserdicht/Waterproof  
21 mm Schlüsselweite/spanner

Verwendung für: / applicable for:  
MERCEDES-BENZ

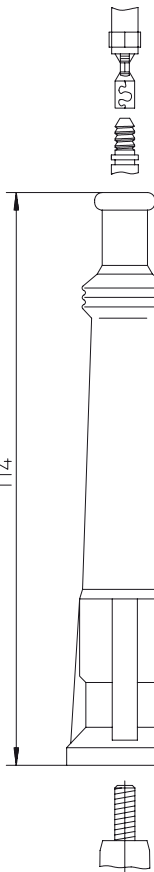

**13206/5**

Polyester/Polyester  
Silikon/Silicone  
5000 Ohm entstört/suppressed  
Wasserdicht/Waterproof

Verwendung für: / applicable for:  
BMW

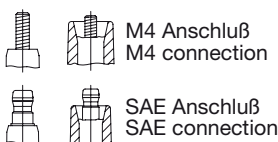

M4 Anschluß  
M4 connection

SAE Anschluß  
SAE connection

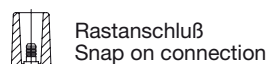

Rastanschluß  
Snap on connection

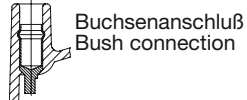

Buchsenanschluß  
Bush connection

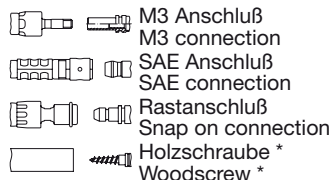

M3 Anschluß  
M3 connection

SAE Anschluß  
SAE connection

Rastanschluß  
Snap on connection

Holzschraube \*  
Woodscrew \*

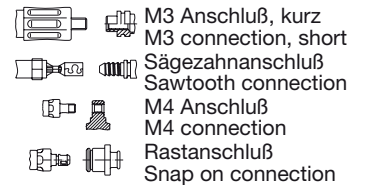

M3 Anschluß, kurz  
M3 connection, short

Sägezahnanschluß  
Sawtooth connection

M4 Anschluß  
M4 connection

Rastanschluß  
Snap on connection

\* Holzschraube für Kat nicht geeignet  
\* Woodscrew not for suitable for kat

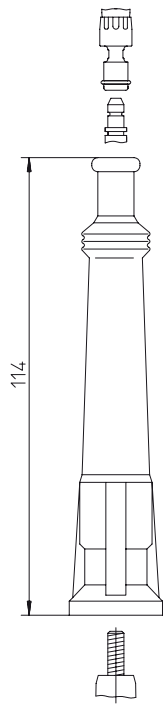

### 13213/5

Polyester/Polyester  
Silikon/Silicone  
5000 Ohm entstört/suppressed  
Wasserdicht/Waterproof

Verwendung für: / applicable for:  
BMW

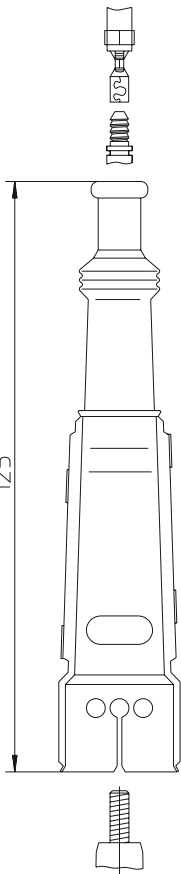

### 13216/5

Polyester/Polyester  
Silikon/Silicone  
Teilschirmung aus Nirostablech/  
partly screened, stainless steel  
5000 Ohm entstört/suppressed  
Wasserdicht/Waterproof  
21 mm Schlüsselweite/spanner

Verwendung für: / applicable for:  
VOLVO

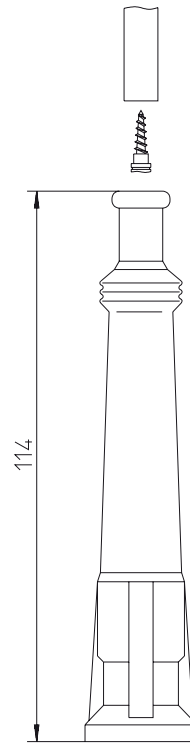

### 13220/5

Polyester/Polyester  
Silikon/Silicone  
5000 Ohm entstört/suppressed  
Wasserdicht/Waterproof

Verwendung für: / applicable for:  
UNIVERSAL

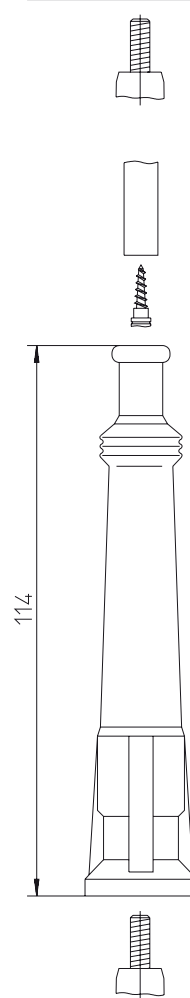

### 13225/5

Polyester/Polyester  
Silikon/Silicone  
5000 Ohm entstört/suppressed  
Wasserdicht/Waterproof

Verwendung für: / applicable for:  
UNIVERSAL

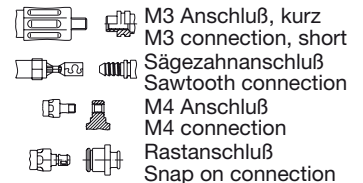
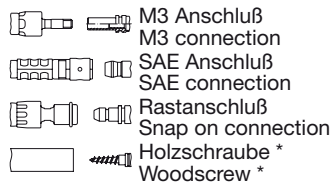
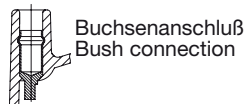
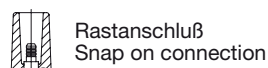
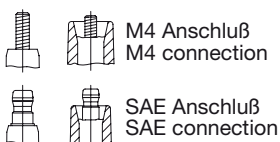

\* Holzschraube für Kat nicht geeignet  
\* Woodscrew not suitable for kat

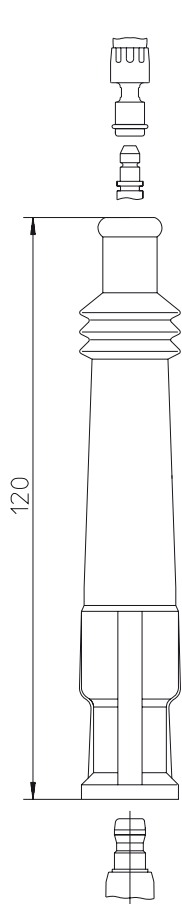

**13226/5**  
 Epoxydharz/Epoxy resin  
 Silikon/Silicone  
 5000 Ohm entstört/suppressed  
 Wasserdicht/Waterproof  
 Verwendung für: / applicable for:  
 BMW

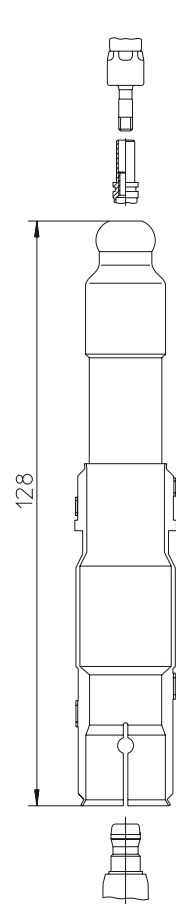

**13229/1**  
 Epoxydharz/Epoxy resin  
 Silikon/Silicone  
 Teilschirmung aus Nirostablech/  
 partly screened, stainless steel  
 1000 Ohm entstört/suppressed  
 Wasserdicht/Waterproof  
 16 mm Schlüsselweite/spanner  
 Verwendung für: / applicable for:  
 MERCEDES-BENZ

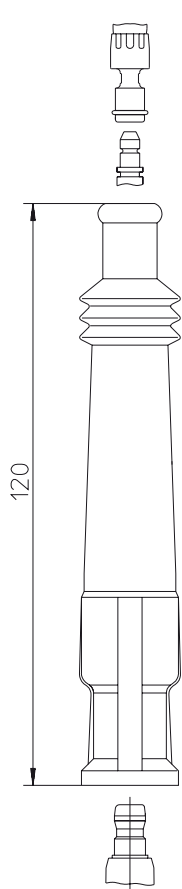

**13226A5**  
 Keramik/Ceramics  
 Silikon/Silicone  
 5000 Ohm entstört/suppressed  
 Wasserdicht/Waterproof  
 Verwendung für: / applicable for:  
 BMW  
 ROLLS-ROYCE

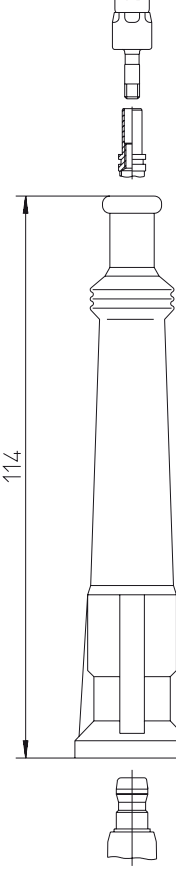

**13243/1**  
 Polyester/Polyester  
 Silikon/Silicone  
 1000 Ohm entstört/suppressed  
 Wasserdicht/Waterproof  
 Verwendung für: / applicable for:  
 UNIVERSAL

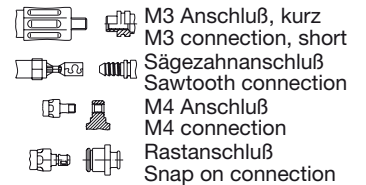
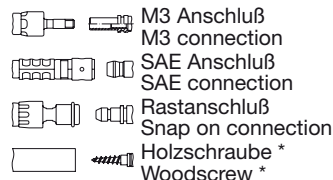
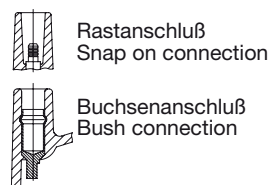
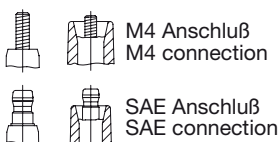

\* Holzschraube für Kat nicht geeignet  
 \* Woodscrew not for suitable for kat

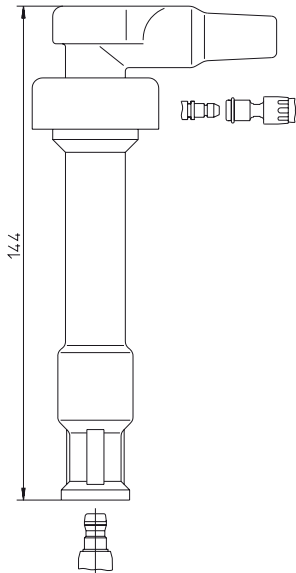

**13246/5**  
 Epoxydharz/Epoxy resin  
 Silikon/Silicone  
 5000 Ohm entstört/suppressed  
 Wasserdicht/Waterproof

Verwendung für: / applicable for:  
 BMW 16 V

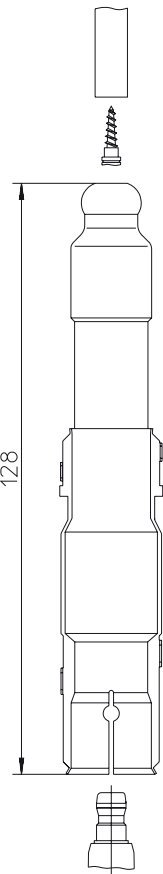

**13247/1**  
 Epoxydharz/Epoxy resin  
 Silikon/Silicone  
 Teilschirmung aus Nirostablech/  
 partly screened, stainless steel  
 1000 Ohm entstört/suppressed  
 Wasserdicht/Waterproof  
 16 mm Schlüsselweite/spanner

Verwendung für: / applicable for:  
 UNIVERSAL

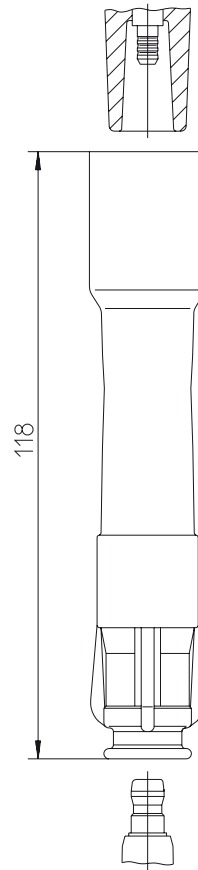

**13249A1,8**  
 Epoxydharz/Epoxy resin  
 Silikon/Silicone  
 1800 Ohm entstört/suppressed  
 Wasserdicht/Waterproof

Verwendung für: / applicable for:  
 BMW Direkt-Zündung  
 BMW direct ignition

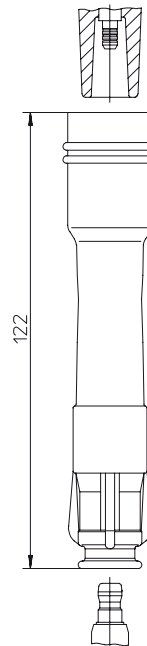

**13249D1,8**  
 Epoxydharz/Epoxy resin  
 Silikon/Silicone  
 1800 Ohm entstört/suppressed  
 Wasserdicht/Waterproof

Verwendung für: / applicable for:  
 BMW Direkt-Zündung  
 BMW direct ignition

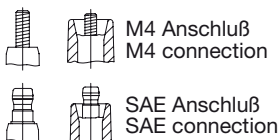

M4 Anschluß  
 M4 connection

SAE Anschluß  
 SAE connection

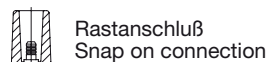

Rastanschluß  
 Snap on connection

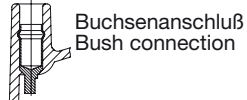

Buchsenanschluß  
 Bush connection

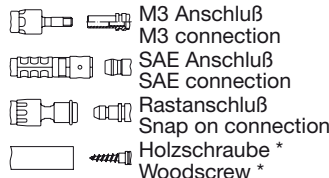

M3 Anschluß  
 M3 connection

SAE Anschluß  
 SAE connection

Rastanschluß  
 Snap on connection

Holzschraube \*  
 Woodscrew \*

\* Holzschraube für Kat nicht geeignet  
 \* Woodscrew not for suitable for kat

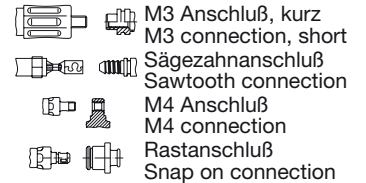

M3 Anschluß, kurz  
 M3 connection, short

Sägezahnanschluß  
 Sawtooth connection

M4 Anschluß  
 M4 connection

Rastanschluß  
 Snap on connection



**13249F1,8**

Epoxydharz/Epoxy resin  
Silikon/Silicone  
1800 Ohm entstört/suppressed  
Wasserdicht/Waterproof

Verwendung für: / applicable for:  
BMW Direkt-Zündung  
BMW direct ignition

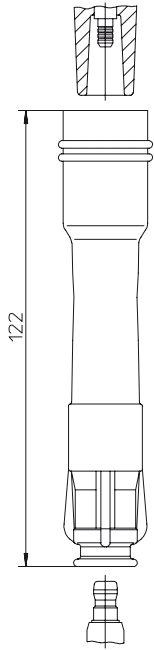

**13250/1**

Epoxydharz/Epoxy resin  
Silikon/Silicone  
Teilschirmung aus Nirostablech/  
partly screened, stainless steel  
1000 Ohm entstört/suppressed  
Wasserdicht/Waterproof  
16 mm Schlüsselweite/spanner

Verwendung für: / applicable for:  
MERCEDES-BENZ

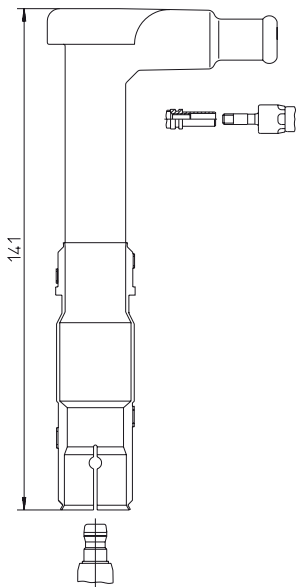

**13262A5**

Epoxydharz/Epoxy resin  
Silikon/Silicone  
Teilschirmung aus Nirostablech/  
partly screened, stainless steel  
5000 Ohm entstört/suppressed  
Wasserdicht/Waterproof  
16 mm Schlüsselweite/spanner

Verwendung für: / applicable for:  
AUDI

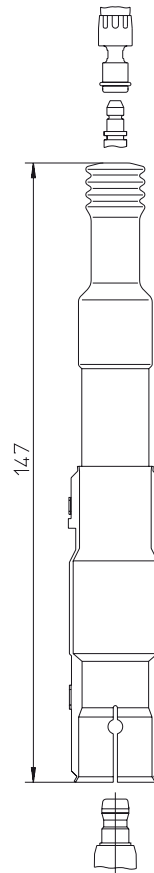

**13272A5**

Epoxydharz/Epoxy resin  
Silikon/Silicone  
Teilschirmung aus Nirostablech/  
partly screened, stainless steel  
5000 Ohm entstört/suppressed  
Wasserdicht/Waterproof  
16 mm Schlüsselweite/spanner

Verwendung für: / applicable for:  
AUDI  
SEAT  
VW

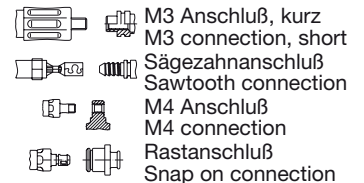
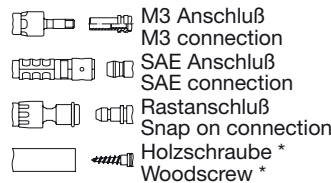
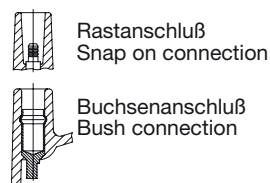
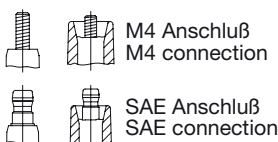
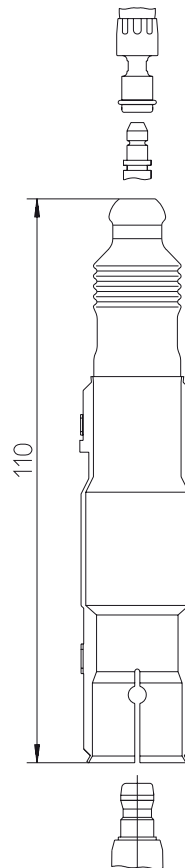

\* Holzschraube für Kat nicht geeignet  
\* Woodscrew not for suitable for kat

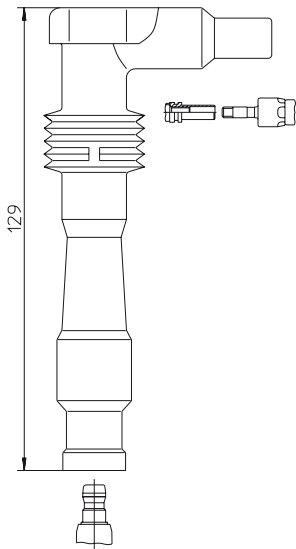

**13280**  
Epoxydharz/Epoxy resin  
Silikon/Silicone  
Wasserdicht/Waterproof

Verwendung für: / applicable for:  
HOLDEN  
OPEL

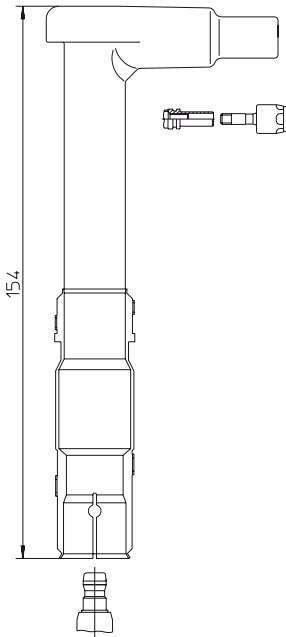

**13292/2**  
Epoxydharz/Epoxy resin  
Silikon/Silicone  
Teilschirmung aus Nirostablech/  
partly screened, stainless steel  
2000 Ohm entstört/suppressed  
Wasserdicht/Waterproof

Verwendung für: / applicable for:  
MERCEDES-BENZ

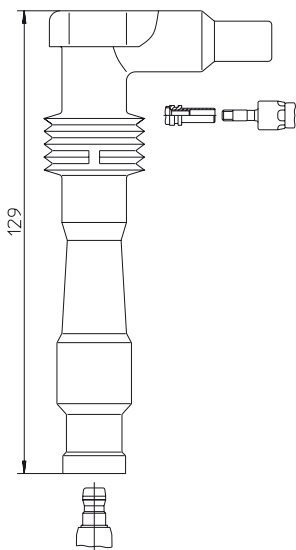

**13280/1**  
Epoxydharz/Epoxy resin  
Silikon/Silicone  
1000 Ohm entstört/suppressed  
Wasserdicht/Waterproof

Verwendung für: / applicable for:  
HOLDEN  
OPEL  
VAUXHALL

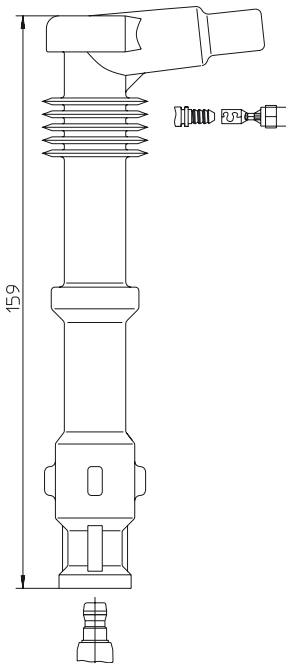

**13293/5**  
Epoxydharz/Epoxy resin  
Silikon/Silicone  
5000 Ohm entstört/suppressed  
Wasserdicht/Waterproof

Verwendung für: / applicable for:  
AUDI 20 V

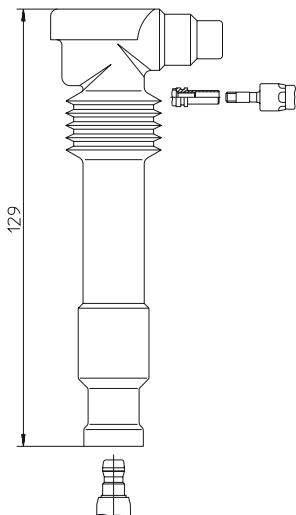

**13281**  
Epoxydharz/Epoxy resin  
Silikon/Silicone  
Wasserdicht/Waterproof

Verwendung für: / applicable for:  
OPEL

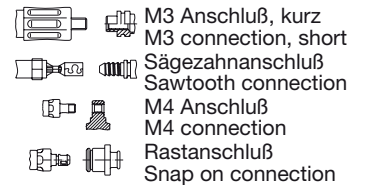
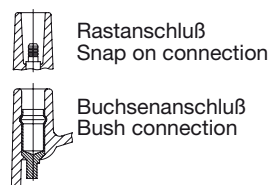
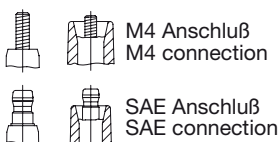

\* Holzschraube für Kat nicht geeignet  
\* Woodscrew not for suitable for kat

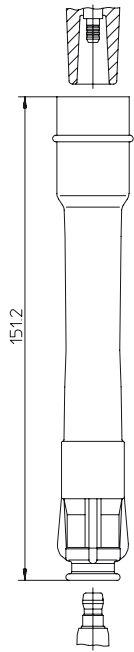

**13296/1,8**

Epoxyharz/Epoxy resin  
Silikon/Silicone  
1800 Ohm entstört/suppressed  
Wasserdicht/Waterproof

Verwendung für: / applicable for:  
BMW Direkt-Zündung  
BMW direct ignition

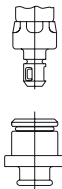

**13297A5**

Epoxyharz/Epoxy resin  
Silikon/Silicone  
Teilschirmung aus Nirostablech/  
partly screened, stainless steel  
5000 Ohm entstört/suppressed  
Wasserdicht/Waterproof

Verwendung für: / applicable for:  
AUDI  
FORD  
SEAT  
SKODA  
VW

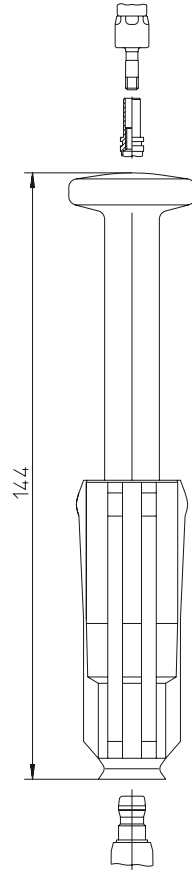
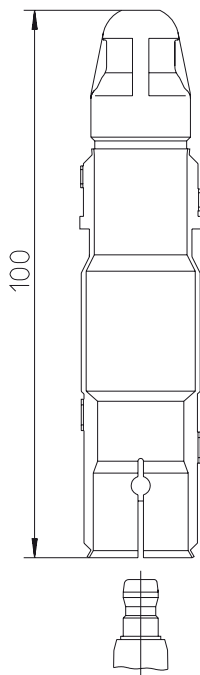

**13303/2**

Epoxyharz/Epoxy resin  
Silikon/Silicone  
2000 Ohm entstört/suppressed  
Wasserdicht/Waterproof

Verwendung für: / applicable for:  
DAEWOO  
MERCEDES-BENZ  
VW

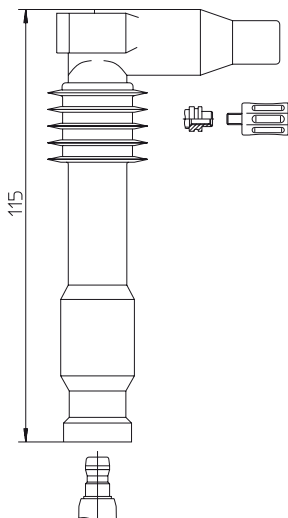

**13306**

Epoxyharz/Epoxy resin  
Silikon/Silicone  
Wasserdicht/Waterproof

Verwendung für: / applicable for:  
OPEL

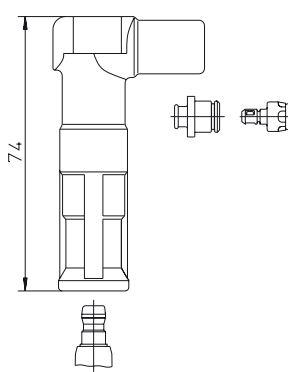

**13308A5**

Polyester/Polyester  
Silikon/Silicone  
5000 Ohm entstört/suppressed  
Wasserdicht/Waterproof

Verwendung für: / applicable for:  
CITROEN  
FIAT  
LANCIA  
PEUGEOT

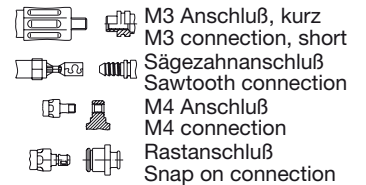
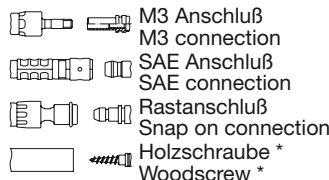
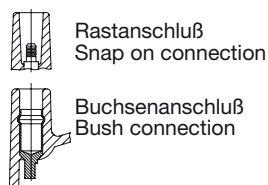
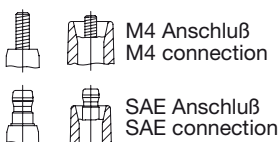

\* Holzschraube für Kat nicht geeignet  
\* Woodscrew not suitable for kat

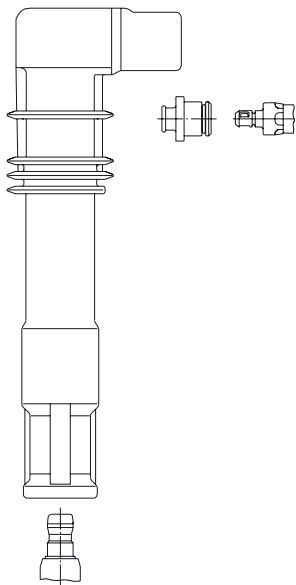

**13309A5**

Silikon/Silicone  
Zinkdruckguß/Zinc cast  
5000 Ohm entstört/suppressed  
Wasserdicht/Waterproof

Verwendung für: / applicable for:  
AUDI  
SEAT  
SKODA  
VW

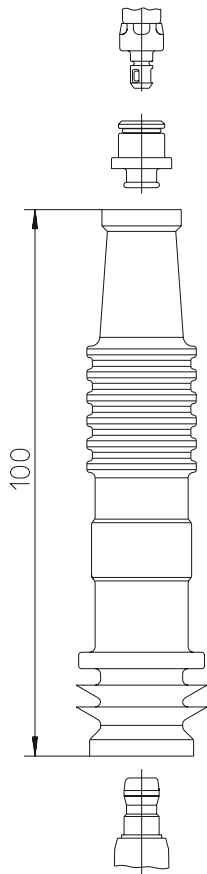

**13310A5**

Polyester/Polyester  
Silikon/Silicone  
5000 Ohm entstört/suppressed  
Wasserdicht/Waterproof

Verwendung für: / applicable for:  
FIAT  
LANCIA

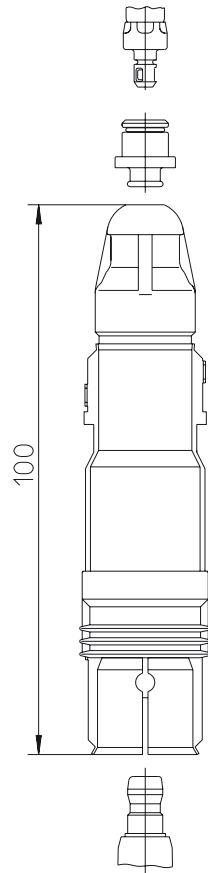

**13313A5**

Polyester/Polyester  
Silikon/Silicone  
Teilschirmung aus Nirostablech/  
partly screened, stainless steel  
5000 Ohm entstört/suppressed  
Wasserdicht/Waterproof

Verwendung für: / applicable for:  
VW

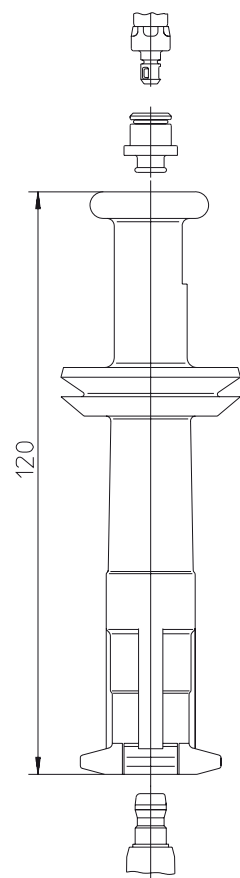

**13315A5**

Polyester/Polyester  
Silikon/Silicone  
5000 Ohm entstört/suppressed  
Wasserdicht/Waterproof

Verwendung für: / applicable for:  
FIAT  
LANCIA

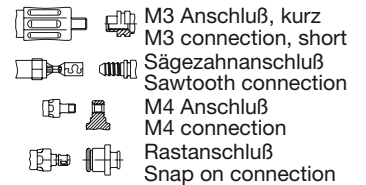
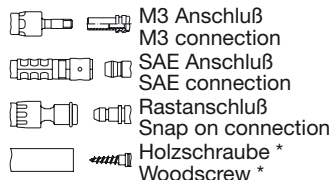
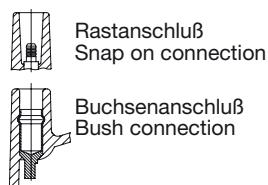
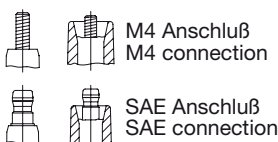

\* Holzschraube für Kat nicht geeignet  
\* Woodscrew not for suitable for kat

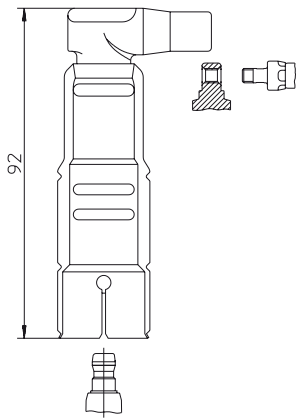

### 13317/5

Epoxydharz/Epoxy resin  
Silikon/Silicone  
Teilschirmung aus Nirostablech/  
partly screened, stainless steel  
5000 Ohm entstört/suppressed  
Wasserdicht/Waterproof

Verwendung für: / applicable for:  
ALFA ROMEO

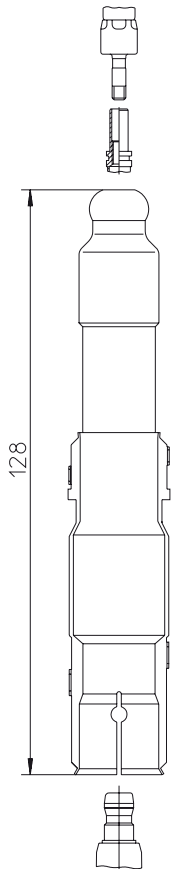

### 13319/2

Epoxydharz/Epoxy resin  
Silikon/Silicone  
Teilschirmung aus Nirostablech/  
partly screened, stainless steel  
2000 Ohm entstört/suppressed  
Wasserdicht/Waterproof

Verwendung für: / applicable for:  
CHRYSLER  
MERCEDES-BENZ  
MERCEDES-BENZ (FJDA)

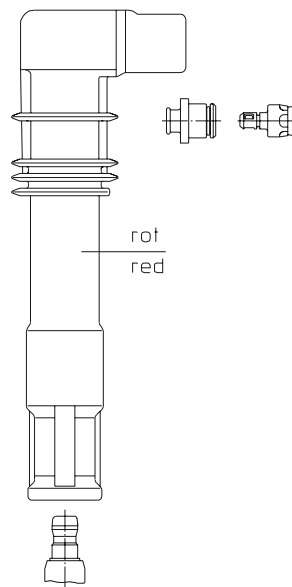

### 13337A5

Silikon/Silicone  
Zinkdruckguß/Zinc cast  
5000 Ohm entstört/suppressed  
Wasserdicht/Waterproof

Verwendung für: / applicable for:  
SEAT  
VW

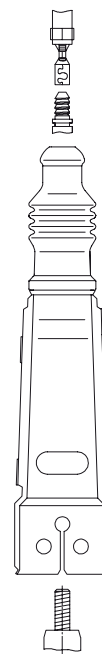

### 13338A5

Silikon/Silicone  
Epoxydharz/Epoxy resin  
Teilschirmung aus Nirostablech/  
partly screened, stainless steel  
5000 Ohm entstört/suppressed  
Wasserdicht/Waterproof  
21 mm Schlüsselweite/spanner

Verwendung für: / applicable for:  
AUDI  
AUSTIN  
FIAT  
LADA  
MERCEDES-BENZ  
PININFARINA  
SEAT  
SKODA  
VW  
WARTBURG

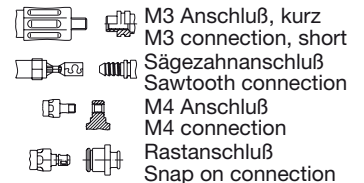
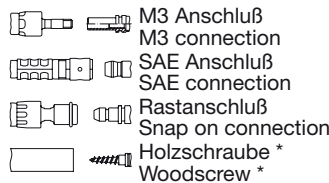
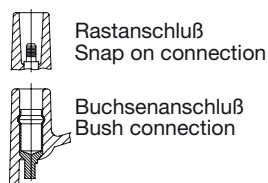
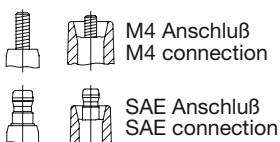

\* Holzschraube für Kat nicht geeignet  
\* Woodscrew not for suitable for kat

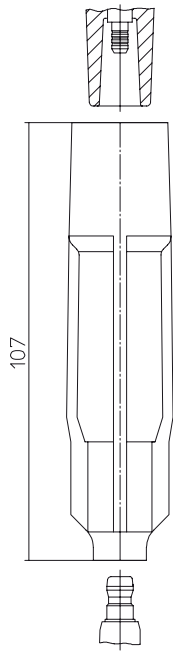

**13343/2**

PBT/PBT  
 Silikon/Silicone  
 2000 Ohm entstört/suppressed  
 Wasserdicht/Waterproof

Verwendung für: / applicable for:  
 DAEWOO  
 MERCEDES-BENZ  
 PUCH  
 SSANGYONG  
 VW

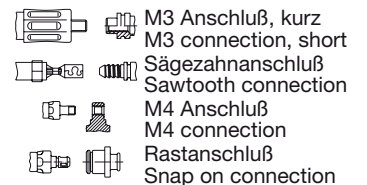
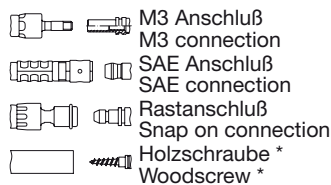
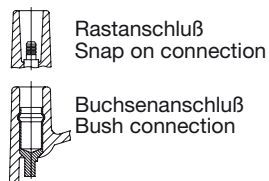
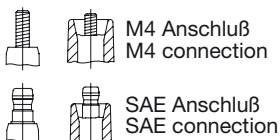

\* Holzschraube für Kat nicht geeignet  
 \* Woodscrew not for suitable for kat

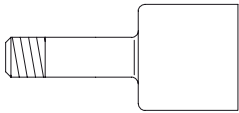
**10046**

Kupferzündleitung/Copper core  
ignition lead  
Messing/Brass  
M3 Gewindeanschluß-Stift/M3  
thread connection pin

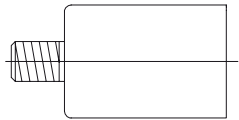
**10054**

Widerstandszündleitung/Resistive  
ignition lead  
Messing/Brass  
M3 Gewindeanschluß-Stift, kurz/  
M3 thread short connection pin

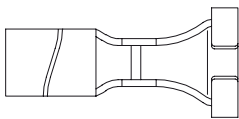
**13200/6**

Kupferzündleitung/Copper core  
ignition lead  
Bronze/Bronze  
Sägezahngew. Anschlußhülse/Saw  
tooth connection sleeve

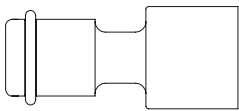
**13206/13**

Kupferzündleitung/Copper core  
ignition lead  
Messing/Brass  
4 mm Rastanschluß-Hülse/4 mm  
snap on connection sleeve

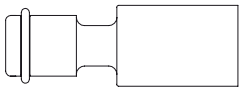
**13262/14**

Kupferzündleitung/Copper core  
ignition lead  
Messing/Brass  
4 mm Rastanschluß-Hülse/4 mm  
snap on connection sleeve

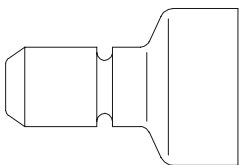
**13297/3**

Kupferzündleitung/Copper core  
ignition lead  
Messing/Brass  
4 mm Rast-Stift/4 mm snap on pin

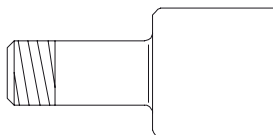
**13301/6**

Kupferzündleitung/Copper core  
ignition lead  
Messing/Brass  
M4 Gewinde Anschluß-Stift/M4  
thread connection pin



**10205/1**

PBT/PBT  
Silikon/Silicone  
1000 Ohm entstört/suppressed  
Wasserdicht/Waterproof

Verwendung für: / applicable for:  
AUDI  
SEAT  
VW  
WARTBURG

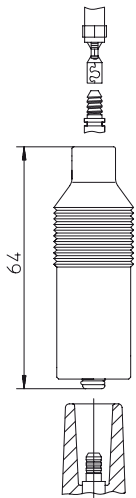

**10205A1**

PBT/PBT  
Silikon/Silicone  
1000 Ohm entstört/suppressed  
Wasserdicht/Waterproof

Verwendung für: / applicable for:  
OPEL

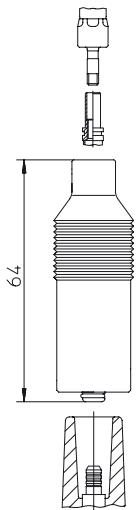

**10206VW1**

PBT/PBT  
Silikon/Silicone  
1000 Ohm entstört/suppressed  
Wasserdicht/Waterproof

Verwendung für: / applicable for:  
ALFA ROMEO  
AUDI  
BMW  
CITROEN  
FIAT  
LANCIA  
PEUGEOT  
SEAT  
SKODA  
VW  
WARTBURG

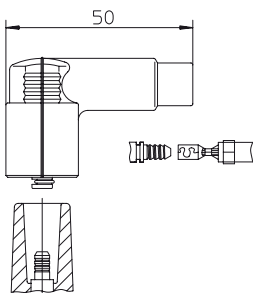

**10206W1H**

PBT/PBT  
Silikon/Silicone  
1000 Ohm entstört/suppressed  
Wasserdicht/Waterproof

Verwendung für: / applicable for:  
AUDI  
NISSAN  
VW

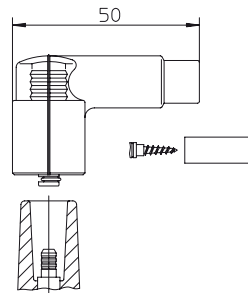

**10206WA1**

PBT/PBT  
Silikon/Silicone  
1000 Ohm entstört/suppressed  
Wasserdicht/Waterproof

Verwendung für: / applicable for:  
BMW

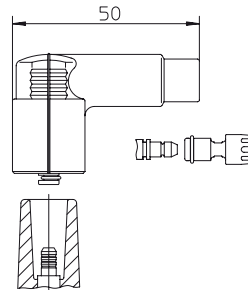

**10221/1**

Polypropylen/Polypropylen  
1000 Ohm entstört/suppressed

Verwendung für: / applicable for:  
UNIVERSAL

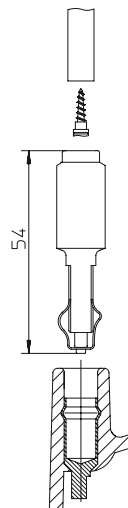

**10221VW1**

Polypropylen/Polypropylen  
Silikon/Silicone  
1000 Ohm entstört/suppressed  
Wasserdicht/Waterproof

Verwendung für: / applicable for:  
AUDI  
BMW  
MERCEDES-BENZ  
SEAT  
VW

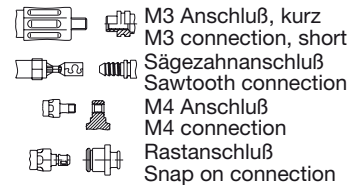
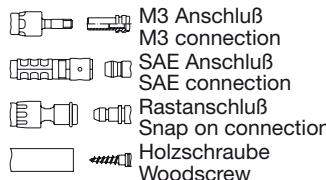
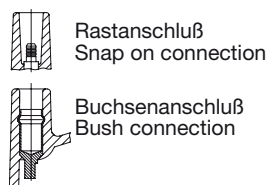
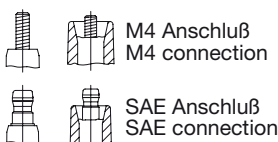
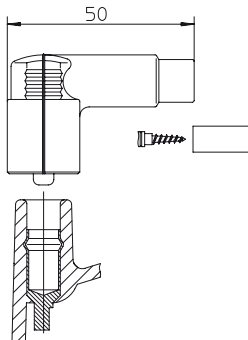

\* Holzschraube für Kat nicht geeignet  
\* Woodscrew not for suitable for kat



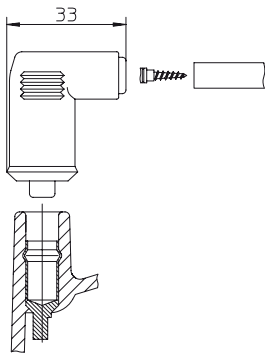

**10221W1**  
 Polypropylen/Polypropylen  
 Silikon/Silicone  
 1000 Ohm entstört/suppressed  
 Wasserdicht/Waterproof

Verwendung für: / applicable for:  
 AUSTIN  
 BMW  
 DODGE  
 FORD  
 OPEL  
 VW  
 VOLVO

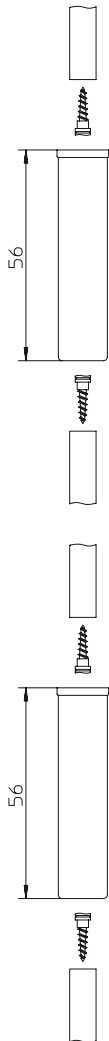

**10222/1**  
 Isolierstoff/Insulating material  
 1000 Ohm entstört/suppressed

Verwendung für: / applicable for:  
 UNIVERSAL

**10222/10**  
 Isolierstoff/Insulating material  
 10000 Ohm entstört/suppressed

Verwendung für: / applicable for:  
 UNIVERSAL

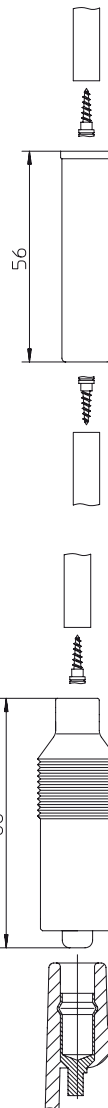

**10222/5**  
 Isolierstoff/Insulating material  
 5000 Ohm entstört/suppressed

Verwendung für: / applicable for:  
 UNIVERSAL

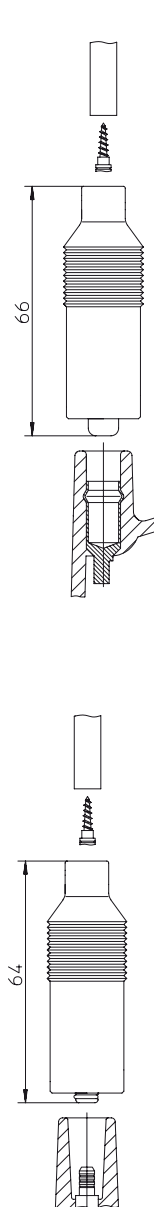

**10223/1**  
 Polypropylen/Polypropylen  
 Silikon/Silicone  
 1000 Ohm entstört/suppressed  
 Wasserdicht/Waterproof

Verwendung für: / applicable for:  
 AUDI  
 BMW  
 SEAT  
 VW

**13200H1**  
 Polypropylen/Polypropylen  
 Silikon/Silicone  
 1000 Ohm entstört/suppressed  
 Wasserdicht/Waterproof

Verwendung für: / applicable for:  
 VW

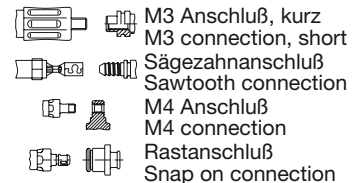
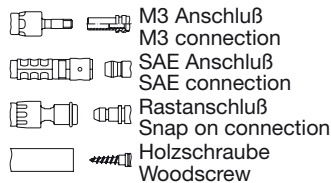
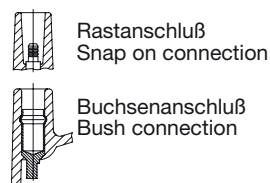
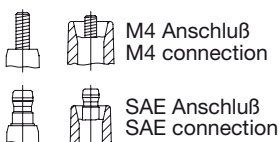

\* Holzschraube für Kat nicht geeignet  
 \* Woodscrew not for suitable for kat

**13207/1**

Polypropylen/Polypropylen  
Silikon/Silicone  
1000 Ohm entstört/suppressed  
Wasserdicht/Waterproof

Verwendung für: / applicable for:  
ALFA ROMEO  
FORD

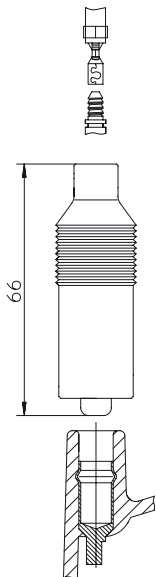

**13207A1**

Polypropylen/Polypropylen  
Silikon/Silicone  
1000 Ohm entstört/suppressed  
Wasserdicht/Waterproof

Verwendung für: / applicable for:  
BMW

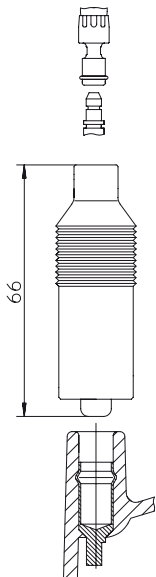

**13208/1**

Polypropylen/Polypropylen  
Silikon/Silicone  
1000 Ohm entstört/suppressed  
Wasserdicht/Waterproof

Verwendung für: / applicable for:  
AUDI  
BMW  
VOLVO  
VW

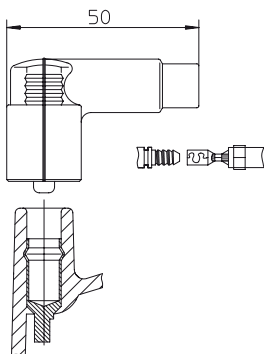

**13208A1**

Polypropylen/Polypropylen  
Silikon/Silicone  
1000 Ohm entstört/suppressed  
Wasserdicht/Waterproof

Verwendung für: / applicable for:  
BMW

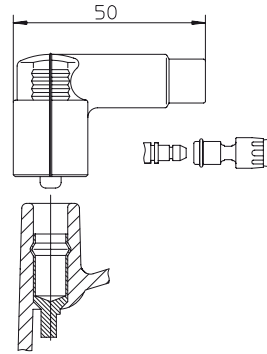

**13210/1**

Polypropylen/Polypropylen  
Silikon/Silicone  
1000 Ohm entstört/suppressed  
Wasserdicht/Waterproof

Verwendung für: / applicable for:  
BMW FÜR 30 KV-ANLAGE

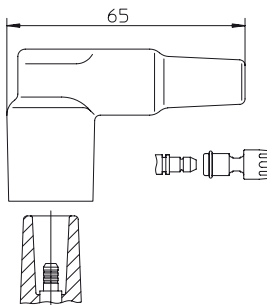

**13210/1B**

Polypropylen/Polypropylen  
Silikon/Silicone  
1000 Ohm entstört/suppressed  
Wasserdicht/Waterproof

Verwendung für: / applicable for:  
FÜR 30 KV-ANLAGE

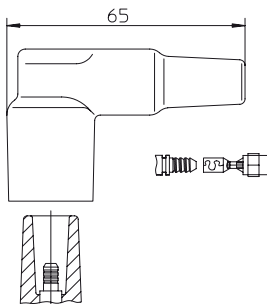

**13211/1**

Polyester/Polyester  
Silikon/Silicone  
1000 Ohm entstört/suppressed  
Wasserdicht/Waterproof

Verwendung für: / applicable for:  
BMW FÜR 30 KV-ANLAGE

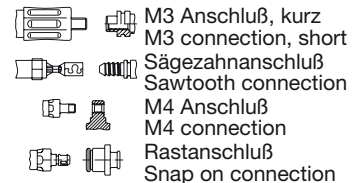
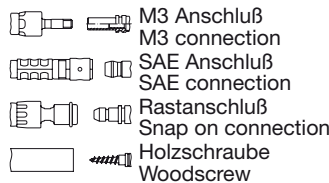
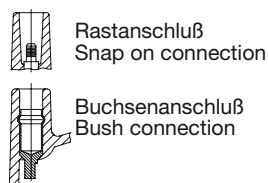
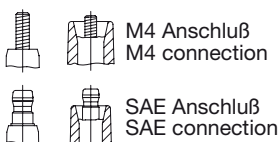
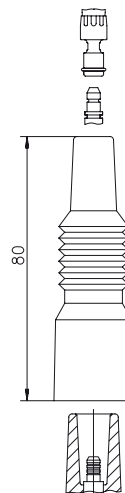

\* Holzschraube für Kat nicht geeignet  
\* Woodscrew not for suitable for kat

**13211/1B**

Polypropylen/Polypropylen  
Silikon/Silicone  
1000 Ohm entstört/suppressed  
Wasserdicht/Waterproof

Verwendung für: / applicable for:  
FÜR 30 KV-ANLAGE

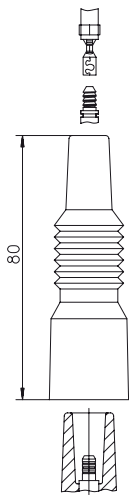

**13211A1**

Polypropylen/Polypropylen  
Silikon/Silicone  
1000 Ohm entstört/suppressed  
Wasserdicht/Waterproof

Verwendung für: / applicable for:  
OPEL FÜR 30 KV-ANLAGE

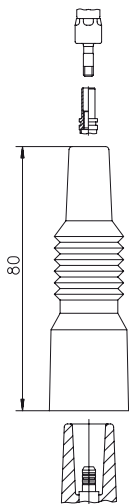

**13211H1**

Polypropylen/Polypropylen  
Silikon/Silicone  
1000 Ohm entstört/suppressed  
Wasserdicht/Waterproof

Verwendung für: / applicable for:  
FÜR 30 KV-ANLAGE

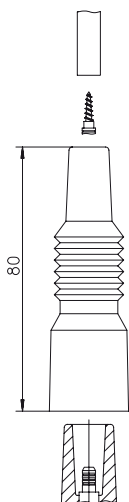

**13221**

Polypropylen/Polypropylen  
Silikon/Silicone  
Wasserdicht/Waterproof

Verwendung für: / applicable for:  
MERCEDES-BENZ

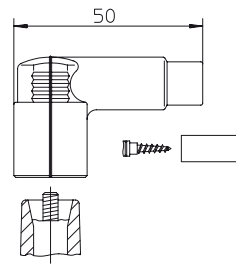

**13222**

Polypropylen/Polypropylen  
Silikon/Silicone  
Wasserdicht/Waterproof

Verwendung für: / applicable for:  
MERCEDES-BENZ

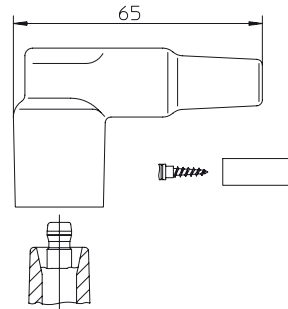

**13248**

Messing/Brass  
Silikon/Silicone  
Wasserdicht/Waterproof

Verwendung für: / applicable for:  
MERCEDES-BENZ FÜR ZÜND-  
SPULE

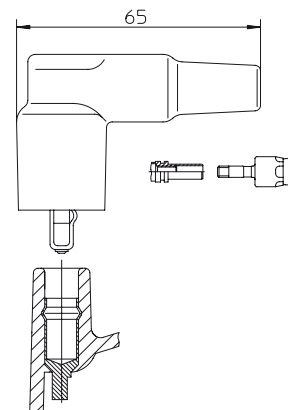

**13248H**

Messing/Brass  
Silikon/Silicone  
Wasserdicht/Waterproof

Verwendung für: / applicable for:  
MERCEDES-BENZ

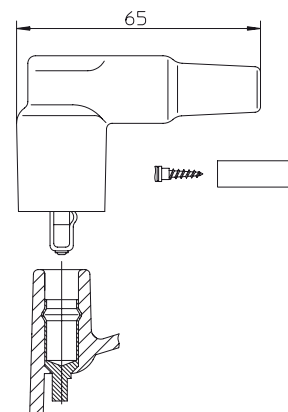

**13254**

Polypropylen/Polypropylen  
Silikon/Silicone  
Wasserdicht/Waterproof

Verwendung für: / applicable for:  
MERCEDES-BENZ  
PORSCHE 928 S

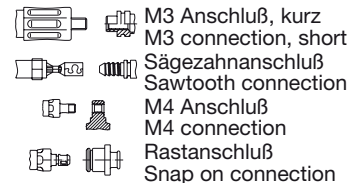
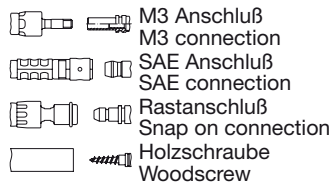
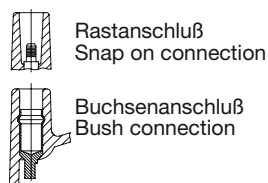
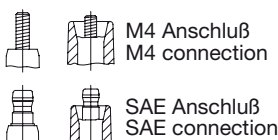
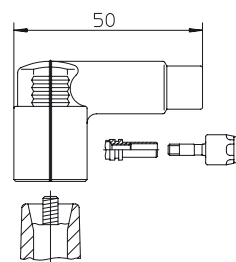

\* Holzschraube für Kat nicht geeignet  
\* Woodscrew not for suitable for kat

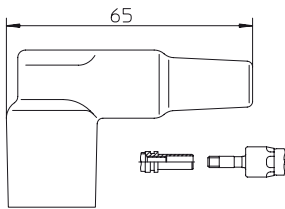

**13255**  
 Polypropylen/Polypropylen  
 Silikon/Silicone  
 Wasserdicht/Waterproof

Verwendung für: / applicable for:  
 MERCEDES-BENZ  
 PORSCHE 944

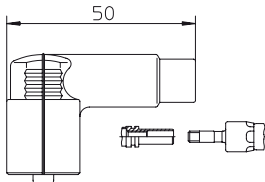
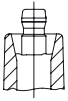

**13256/1**  
 Polypropylen/Polypropylen  
 Silikon/Silicone  
 1000 Ohm entstört/suppressed  
 Wasserdicht/Waterproof

Verwendung für: / applicable for:  
 FORD  
 MERCEDES-BENZ

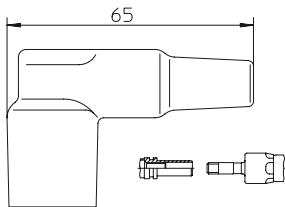
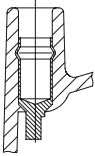

**13257/1**  
 Polypropylen/Polypropylen  
 Silikon/Silicone  
 1000 Ohm entstört/suppressed  
 Wasserdicht/Waterproof

Verwendung für: / applicable for:  
 PORSCHE FÜR 30 KV-ANLAGE

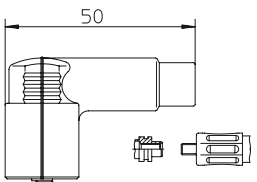
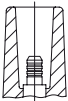

**13258/1**  
 Polypropylen/Polypropylen  
 Silikon/Silicone  
 1000 Ohm entstört/suppressed  
 Wasserdicht/Waterproof

Verwendung für: / applicable for:  
 OPEL 16 V

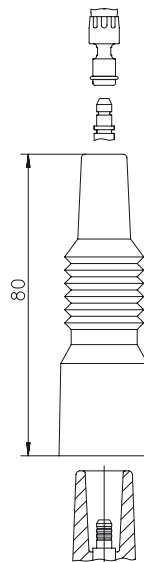
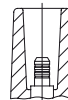

**13261A1**  
 PBT/PBT  
 Silikon/Silicone  
 1000 Ohm entstört/suppressed  
 Wasserdicht/Waterproof

Verwendung für: / applicable for:  
 AUDI

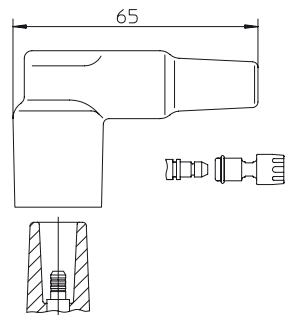

**13268A1**  
 PBT/PBT  
 Silikon/Silicone  
 1000 Ohm entstört/suppressed  
 Wasserdicht/Waterproof

Verwendung für: / applicable for:  
 AUDI

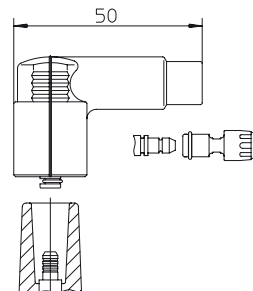

**13270A1**  
 PBT/PBT  
 Silikon/Silicone  
 1000 Ohm entstört/suppressed  
 Wasserdicht/Waterproof

Verwendung für: / applicable for:  
 AUDI  
 FORD  
 MERCEDES-BENZ  
 SEAT  
 VW

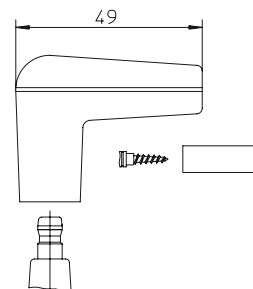

**13277**  
 Silikon/Silicone  
 Wasserdicht/Waterproof

Verwendung für: / applicable for:  
 UNIVERSAL (auch für Zündkerzen)  
 UNIVERSAL (for spark plugs too)

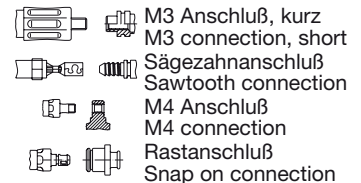
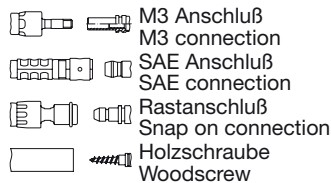
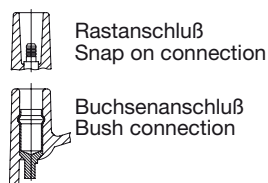
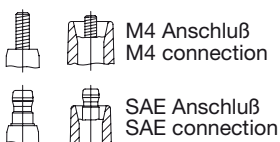

\* Holzschraube für Kat nicht geeignet  
 \* Woodscrew not suitable for kat

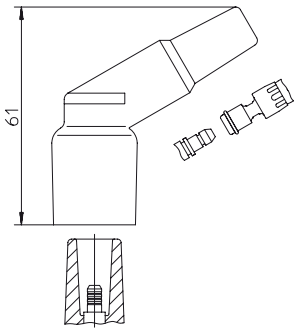

**13290A**  
 Polypropylen/Polypropylen  
 Silikon/Silicone  
 Wasserdicht/Waterproof

Verwendung für: / applicable for:  
 BMW

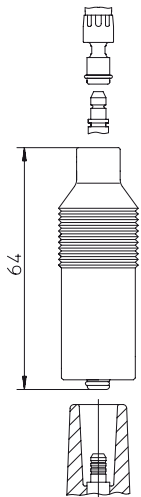

**13295A1**  
 Silikon/Silicone  
 1000 Ohm entstört/suppressed  
 Wasserdicht/Waterproof

Verwendung für: / applicable for:  
 SEAT  
 VW

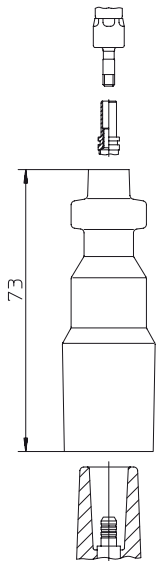

**13550**  
 Silikon/Silicone  
 Wasserdicht/Waterproof

Verwendung für: / applicable for:  
 MERCEDES-BENZ

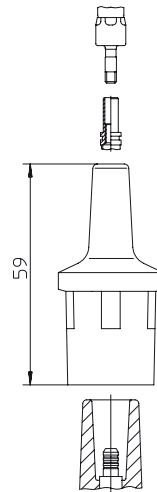

**13551**  
 Silikon/Silicone  
 Wasserdicht/Waterproof

Verwendung für: / applicable for:  
 DAEWOO  
 MERCEDES-BENZ  
 VW

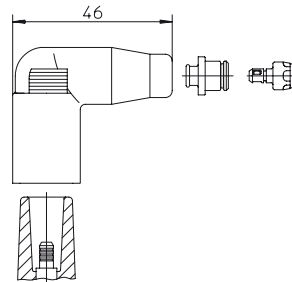

**13552A1**  
 Silikon/Silicone  
 1000 Ohm entstört/suppressed  
 Wasserdicht/Waterproof

Verwendung für: / applicable for:  
 AUDI  
 SEAT  
 SKODA  
 SVW  
 VW

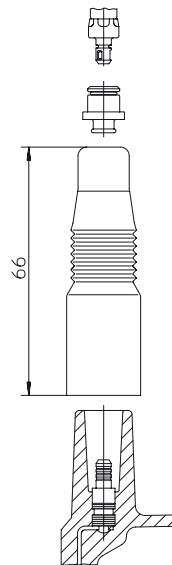

**13555A1**  
 PBT/PBT  
 Silikon/Silicone  
 1000 Ohm entstört/suppressed  
 Wasserdicht/Waterproof

Verwendung für: / applicable for:  
 AUDI  
 SEAT  
 SKODA  
 VW

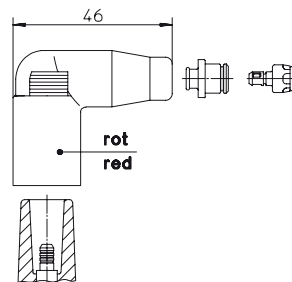

**13558A1**  
 PBT/PBT  
 Silikon/Silicone  
 1000 Ohm entstört/suppressed  
 Wasserdicht/Waterproof

Verwendung für: / applicable for:  
 SEAT  
 VW

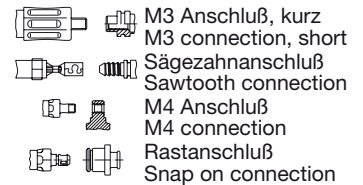
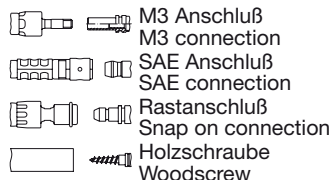
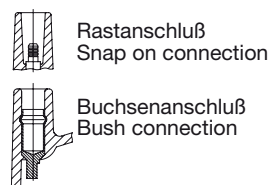
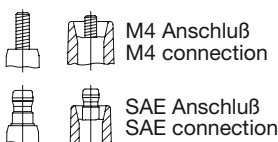

\* Holzschraube für Kat nicht geeignet  
 \* Woodscrew not for suitable for kat

# Allgemeine Verkaufs- und Lieferungsbedingungen

## Bremi Fahrzeug-Elektrik GmbH + Co. KG

### I.

#### Allgemeine Bestimmungen – Geltungsbereich

1. Die folgenden Allgemeinen Geschäftsbedingungen gelten für alle gegenwärtigen und zukünftigen Geschäftsbeziehungen, die wir mit Unternehmern im Sinn von § 310 Abs. 1 BGB eingehen. Dies gilt auch dann, wenn auf sie bei späteren Geschäften nicht mehr ausdrücklich Bezug genommen wird. Abweichende, entgegenstehende oder ergänzende Allgemeine Geschäftsbedingungen des Unternehmers werden selbst bei Kenntnis nicht Vertragsbestandteil, es sei denn, wir hätten ihrer Geltung ausdrücklich schriftlich zugestimmt. Eine Vertragserfüllung durch uns ersetzt diese schriftliche Bestätigung nicht.
2. An Abbildungen, Zeichnungen, Kalkulationen und anderen Unterlagen (im Folgenden "Unterlagen") behalten wir uns unsere Eigentums- und urheberrechtlichen Verwertungsrechte uneingeschränkt vor. Die Unterlagen dürfen nur nach unserer vorherigen schriftlichen Zustimmung Dritten zugänglich gemacht werden und sind, wenn uns der Auftrag nicht erteilt wird, uns auf Verlangen unverzüglich zurückzugeben. Die Sätze 1 und 2 gelten entsprechend für Unterlagen des Unternehmers. Ausnahmsweise dürfen die Unterlagen jedoch solchen Dritten zugänglich gemacht werden, denen wir zulässigerweise Lieferungen übertragen haben.
3. Unsere Angebote sind freibleibend und unverbindlich, sofern sich aus der Auftragsbestätigung nichts anderes ergibt. Mit der Bestellung erklärt der Unternehmer verbindlich sein Vertragsangebot. Wir behalten uns vor, die Annahme der Bestellung - etwa nach Prüfung der Bonität des Unternehmers - abzulehnen. Im Übrigen sind wir berechtigt, das in der Bestellung liegende Vertragsangebot innerhalb von 14 Tagen durch Zusendung einer Auftragsbestätigung anzunehmen oder dem Besteller innerhalb dieser Frist die bestellte Ware zuzusenden. Für den Inhalt des Liefervertrags ist unsere Auftragsbestätigung maßgebend. Alle Vereinbarungen, insbesondere die Übernahme von Garantien oder Beschaffungsrisiken, die zwischen uns und dem Unternehmer zwecks Ausführung eines Vertrags getroffen werden, sind in diesem Vertrag schriftlich niedergelegt.
4. Der Vertragsschluss erfolgt unter dem Vorbehalt, im Falle unverschuldeter nicht richtiger oder nicht ordnungsgemäßer Selbstlieferung nicht oder nur teilweise zu leisten. Im Falle der Nichtverfügbarkeit oder der nur teilweisen Verfügbarkeit der Leistung wird der Unternehmer unverzüglich informiert. Die Gegenleistung wird unverzüglich erstattet.
5. Von uns bestätigte Aufträge kann der Unternehmer nicht stornieren, es sei denn, dass wir ausnahmsweise schriftlich zustimmen. In diesem Falle können wir eine Entschädigung fordern, deren Höhe die vertragliche Gegenleistung des Unternehmers nicht überschreiten soll.
6. Wir behalten uns Konstruktions- und Formänderungen bis zur Lieferung vor, durch die jedoch unter Berücksichtigung unserer Interessen die Interessen des Unternehmers nicht unzumutbar beeinträchtigt werden dürfen.
7. Die Rechte des Unternehmers aus dem Vertrag sind nur mit unserer vorherigen Zustimmung übertragbar.

### II.

#### Lieferung und Abnahme

1. Der Unternehmer stellt uns bei Ware, die nach seinen Anforderungen, Spezifikationen usw. gefertigt wird, von allen Ansprüchen frei, die Dritte aus gewerblichen Schutzrechten, Urheberrechten, Warnzeichen usw. gegen uns oder ein mit uns verbundenes Unternehmen geltend machen können. Soweit wir hier Bedenken haben, sind wir verpflichtet, den Unternehmer hierauf aufmerksam zu machen. Eine eigenständige Prüfungspflicht trifft uns nicht. Das gleiche gilt, wenn der Unternehmer unsere Ware ohne unser Einverständnis so verwendet, dass Rechte Dritter verletzt werden können.
2. Soweit sich dies nicht bereits aus der Natur des Schuldverhältnisses ergibt, z.B. Sukzessivlieferungsvertrag, sind wir zu Teilleistungen berechtigt, wenn deren Entgegennahme dem Unternehmer zumutbar ist.

### III.

#### Preise und Zahlungsbedingungen

1. Sofern unser Angebot oder unsere schriftliche Auftragsbestätigung nichts anderes beinhaltet, verstehen sich unsere Preise in EURO ab Werk ausschließliche Verpackung und Versicherung (beachte: ordnungsgemäße Verpackung ist Sache des Verkäufers. Wer Verpackungskosten trägt, ist Vereinbarungssache. Transportkosten trägt Unternehmer, wenn Ware an anderen als Erfüllungsort geschickt wird.). Besondere Verpackungswünsche des Unternehmers sind uns frühestmöglich, spätestens jedoch zwei Wochen vor dem Ablieferungs- bzw. Verladetermin, schriftlich mitzuteilen. Die in der Rechnung ausdrücklich als Leihverpackung kenntlich gemachten Paletten und ähnliche Lademittel sind in geeignetem und unbeschädigtem Zustand frachtfrei zurückzugeben.
2. Die gesetzliche Mehrwertsteuer ist nicht in unseren Preisen eingeschlossen. Sie wird in gesetzlicher Höhe am Tag der Rechnungsstellung in der Rechnung gesondert ausgewiesen.
3. Unsere Rechnungen sind binnen 30 Tagen ab Rechnungsdatum rein netto zahlbar. Bei einer Zahlung innerhalb von 14 Tagen ab Rechnungsdatum ist der Unternehmer zum Abzug von 2 % Skonto vom Nettowarenwert berechtigt. Für die Rechtzeitigkeit der jeweils geschuldeten Zahlung ist im bargeldlosen Zahlungsverkehr, namentlich bei Überweisungen, nicht die Vornahme der erforderlichen Leistungshandlung, sondern der Eintritt des Leistungserfolges in der Weise maßgebend, dass bei bargeldloser Zahlung der geschuldete Betrag auf unserem Konto eingegangen sein muss. Andere Zahlungsmittel als Bargeld oder Überweisung auf die von uns angegebenen Konten werden nur aufgrund schriftlicher Vereinbarung und nur erfüllungshalber angenommen. Alle Zahlungen sind spesenfrei zu leisten. Bei Zielüberschreitungen werden die gesetzlichen Verzugszinsen in Höhe von 8 Prozentpunkten über dem jeweiligen Basiszinssatz als objektiver Mindestschaden berechnet. Die Geltendmachung weiteren Verzugs Schadens wird hierdurch nicht ausgeschlossen.

4. Die Zurückhaltung von Zahlungen durch den Unternehmer ist ausgeschlossen, sofern die Gegenansprüche aus einem anderen Vertragsverhältnis resultieren. Beruhen die Gegenansprüche auf demselben Vertragsverhältnis, ist die Zurückhaltung von Zahlungen nur zulässig, wenn es sich um rechtskräftig festgestellte, unbestrittene oder von uns anerkannte Gegenansprüche handelt.
5. Ebenso stehen Aufrechnungsrechte dem Unternehmer nur zu, wenn seine Gegenansprüche rechtskräftig festgestellt, unbestritten oder von uns anerkannt sind.
6. Der Unternehmer erklärt sich damit einverstanden, dass wir gegenüber fälligen Forderungen des Unternehmers die Aufrechnung mit eigenen fälligen Forderungen erklären können, auch wenn die Fälligkeitstermine der gegenseitigen Forderungen verschieden sind.  
Wir behalten uns das Recht vor, unsere Preise entsprechend zu ändern, wenn nach Abschluss des Vertrages Kostensenkungen oder Kostenerhöhungen, insbesondere aufgrund von Materialpreisänderungen, eintreten. Diese werden wir dem Unternehmer auf Verlangen nachweisen. Die Preisänderung darf dabei nur im Rahmen und zum Ausgleich der betreffenden Kostenänderungen erfolgen und ist daher auf den kostenabhängigen Teil des Gesamtpreises beschränkt.
7. Anteilige Werkzeugkosten sind, soweit nichts anderes schriftlich vereinbart, mit 50 % bei Auftragserteilung und 50 % bei Ausfallmustervorlage sofort ohne Abzug bezahlbar.
8. Teillieferungen sind mit den in Nr. 3 genannten Fristen je gesondert zu bezahlen. Zahlt der Unternehmer nicht rechtzeitig, so können wir die weitere Erledigung der Bestellung aussetzen oder gegen Bereitstellung der genannten Warenmenge den vereinbarten Preis verlangen. Das gleiche gilt bei Abrufaufträgen, wenn der Unternehmer die Ware nicht ordnungsgemäß abrufen. Auf Abruf gekaufte Ware muss der Unternehmer mangels anderer schriftlicher Vereinbarung spätestens innerhalb von sechs Monaten vollständig abgerufen haben. Abrufe müssen spätestens sechs Wochen vor dem Liefertermin bei uns eingehen.

#### IV.

##### Kreditgrundlage

1. Voraussetzung der Belieferung ist die Kreditwürdigkeit des Unternehmers. Erhalten wir nach Vertragsabschluss Auskünfte, die die Gewährung eines Kredits in der sich aus dem Auftrag ergebenden Höhe nicht unbedenklich erscheinen lassen, oder ergeben sich Tatsachen, die einen Zweifel in dieser Hinsicht zulassen, tritt insbesondere eine erhebliche Verschlechterung der Vermögenslage (Zwangsvollstreckung, Zahlungseinstellung, Insolvenz, Geschäftsauflösung, Geschäftsübergang) ein, sind wir berechtigt, angemessene Vorauszahlung bzw. Sicherheitsleistung oder Barzahlung ohne Rücksicht auf entgegenstehende frühere Vereinbarungen zu verlangen.
2. Unter den gleichen Voraussetzungen sind wir nach Belieferung des Unternehmers berechtigt, dessen Lager zu besichtigen und unter Eigentumsvorbehalt stehende Waren ohne Rücksicht auf entgegenstehende frühere Vereinbarungen bis zur Barzahlung vorläufig sicherzustellen. Transport- und Unterstellungskosten trägt der Unternehmer.

#### V.

##### Lieferzeit

1. Die Einhaltung von vereinbarten Fristen für Lieferungen setzt den rechtzeitigen Eingang sämtlicher vom Unternehmer zu liefernder Unterlagen, erforderlicher Genehmigungen und Freigaben, insbesondere von Plänen, sowie die Einhaltung der vereinbarten Zahlungsbedingungen und sonstigen Verpflichtungen durch den Unternehmer voraus. Werden diese Voraussetzungen nicht rechtzeitig erfüllt, so verlängern sich die Fristen angemessen, die Einrede des nicht erfüllten Vertrages sowie die Geltendmachung uns zustehender Zurückbehaltungsrecht bleibt vorbehalten. Dies gilt nicht, wenn wir die Verzögerung zu vertreten haben.
2. Die vereinbarte Lieferfrist verlängert sich unbeschadet unserer Rechte aus Verzug um den Zeitraum, in dem uns eine dauernde oder aufschiebende Einrede zusteht, insbesondere währenddessen der Unternehmer mit seinen Verpflichtungen aus diesem oder einem anderen Vertrag in Verzug ist.
3. Die Lieferfrist verlängert sich angemessen bei Maßnahmen im Rahmen von rechtmäßigen Arbeitskämpfen, insbesondere Streik und Aussperrung im eigenen Betrieb sowie unabhängig von der Rechtmäßigkeit der Arbeitskämpfmaßnahmen in Drittbetrieben, sofern uns kein Übernahme-, Vorsorge- oder Abwendungsverpflichtung trifft, des Weiteren bei Eintritt unvorhergesehener Ereignisse wie Mobilmachung, Krieg, Blockade, Aus- und Einfuhrverbote, insbesondere gesetzliche oder behördliche Vorschriften, Roh- oder Brennstoffmangel, Feuer oder Verkehrssperrungen oder höhere Gewalt, soweit solche Hindernisse nachweislich auf die Fertigstellung oder Ablieferung des Liefergegenstandes von Einfluss sind und bei uns, einem Vor- oder Unterlieferanten oder Transporteur eintreten und von uns nicht zu vertreten sind.
4. Bei teilweisem oder vollständigem Wegfall der Bezugsquellen von Bremi, gleich welcher Art, ist Bremi nicht verpflichtet, Deckungskäufe bei Dritten zu tätigen. Deckungskäufe oder sonstige Ansprüche stehen unseren Vertragspartnern aus einer etwaig von uns vertretbaren oder nicht vertretbaren Nichteinhaltung von Lieferfristen nicht zu.
5. Der Liefertermin ist eingehalten, wenn die Ware bis zu seinem Ablauf unser Werk Dömitz verlassen hat oder die Versandbereitschaft mitgeteilt ist.

Wir haften nach den gesetzlichen Bestimmungen, soweit der zugrunde liegende Kaufvertrag ein Fixgeschäft im Sinn von § 286 Abs. 2 Nr. 4 BGB oder von § 376 HGB ist. Wir haften auch nach den gesetzlichen Bestimmungen, sofern als Folge eines von uns zu vertretenden Lieferverzugs der Unternehmer berechtigt ist, geltend zu machen, dass sein Interesse an der weiteren Vertragserfüllung in Fortfall geraten ist. Wir haften ferner nach den gesetzlichen Bestimmungen, sofern der Lieferverzug auf einer von uns zu vertretenden vorsätzlichen oder grob fahrlässigen Vertragsverletzung beruht. Sofern der Lieferverzug nicht auf einer von uns zu vertretenden vorsätzlichen oder grob fahrlässigen Vertragsverletzung beruht, ist unsere Schadensersatzhaftung auf den vorhersehbaren, typischerweise eintretenden Schaden begrenzt. Ein Verschulden unserer Vertreter oder Erfüllungsgehilfen ist uns zuzurechnen.

Wir haften auch nach den gesetzlichen Bestimmungen, soweit der von uns zu vertretende Lieferverzug auf der schuldhaften Verletzung einer wesentlichen Vertragspflicht beruht; in diesem Fall ist aber die Schadensersatzhaftung auf

den vorhersehbaren, typischerweise eintretenden Schaden begrenzt.

6. Kommt der Unternehmer in Schuldner-/Annahmeverzug oder verletzt er schuldhaft sonstige Mitwirkungspflichten, sind wir berechtigt, den uns insoweit entstehenden Schaden einschließlich etwaiger Mehraufwendungen ersetzt zu verlangen. Dem Unternehmer bleibt der Nachweis gestattet, dass uns überhaupt kein Schaden entstanden ist oder dieser wesentlich niedriger als die Pauschale ist. Dasselbe gilt für den Fall, dass sich die Übergabe der Kaufsache auf Wunsch des Unternehmers verzögert. Weitergehende Ansprüche unsererseits bleiben vorbehalten.
7. Sofern der Unternehmer in Schuldner-/Annahmeverzug ist oder sonstige Mitwirkungspflichten schuldhaft verletzt oder die Übergabe der Sache auf seinen Wunsch hinausgeschoben wird, geht die Gefahr eines zufälligen Untergangs oder einer zufälligen Verschlechterung der Kaufsache in dem Zeitpunkt auf den Unternehmer über, in dem dieser in Annahme- oder Schuldnerverzug geraten ist, die geschuldete Mitwirkungshandlung unterlassen hat oder die Übergabe auf seinen Wunsch hinausgeschoben wird.

## VI.

### Eigentumsvorbehalt

1. Wir behalten uns das Eigentum an der Kaufsache bis zum Eingang aller Zahlungen aus der Geschäftsverbindung vor. Im Falle des Bestehens eines Kontokorrentverhältnisses bezieht sich der Vorbehalt auf den anerkannten Saldo. Dies schließt neben der vollständigen Kaufpreiszahlung einschließlich Mehrwertsteuer auch Zinsen und sonstige Nebenkosten, wie zum Beispiel vom Unternehmer zu tragende Frachtkosten, mit ein.
2. Während der Dauer unseres Eigentumsvorbehaltes ist der Unternehmer verpflichtet, die Kaufsache pfleglich zu behandeln. Er ist des Weiteren verpflichtet, diese auf eigene Kosten gegen Feuer-, Wasser- und Diebstahlschäden ausreichend zum Neuwert zu versichern. Sofern Wartungs- und Inspektionsarbeiten erforderlich sind, muss der Unternehmer diese auf eigene Kosten rechtzeitig durchführen.
3. Bei Pfändungen oder sonstigen Eingriffen Dritter hat der Unternehmer zu widersprechen und uns unverzüglich auf schnellstem Wege Anzeige zu machen, damit wir erforderlichenfalls Klage gemäß § 771 ZPO erheben können. Soweit der Dritte nicht in der Lage ist, uns die gerichtlichen und außergerichtlichen Kosten einer Klage gemäß § 771 ZPO zu erstatten, haftet der Unternehmer für den uns entstandenen Ausfall. Sicherungsübereignungen, Verpfändungen und andere unsere Rechte gefährdende Verfügungen über die unter Eigentumsvorbehalt stehende Sache sind dem Unternehmer nicht gestattet. Bei vertragswidrigem Verhalten des Unternehmers, insbesondere bei Zahlungsverzug, sind wir berechtigt, die Kaufsache zurückzunehmen. In der Zurücknahme der Kaufsache durch uns liegt ein Rücktritt vom Vertrag. Wir sind nach Rücknahme der Kaufsache zu deren Verwertung befugt, der Verwertungserlös ist auf die Verbindlichkeiten des Unternehmers – abzüglich angemessener Verwertungskosten – anzurechnen.
4. Kommt der Unternehmer mit der Erfüllung seiner Verbindlichkeit ganz oder teilweise in Verzug, so wird die gesamte Restschuld zuzüglich Verzugszinsen sofort fällig. Wir sind außerdem berechtigt, von sämtlichen noch nicht ausgeführten Verträgen zurückzutreten oder Lieferungen bzw. sonstige Leistungen aus sämtlichen Verträgen wegen der uns zu-

stehenden Forderungen zurückzuhalten. Der Unternehmer kann dieses Zurückbehaltungsrecht durch Gestellung einer selbstschuldnerischen und unbefristeten Bürgschaft einer deutschen Großbank, Sparkasse oder Volksbank in Höhe sämtlicher ausstehender Forderungen abwenden.

5. Der Unternehmer ist zur getrennten Lagerung und Kennzeichnung unserer unter Eigentumsvorbehalt stehenden Waren verpflichtet.
6. Der Unternehmer ist berechtigt, die Kaufsache im ordentlichen Geschäftsgang weiterzuverkaufen; er tritt uns jedoch bereits jetzt alle Forderungen einschließlich etwaiger Nebenrechte und Sicherheiten, in Höhe des Faktura-Endbetrages (einschließlich Mehrwertsteuer) unserer Forderung ab, die ihm aus der Weiterveräußerung gegen seine Abnehmer oder Dritte erwachsen, und zwar unabhängig davon, ob die Kaufsache ohne oder nach Verarbeitung weiterverkauft worden ist. Wir nehmen die Abtretung an. Eine Befugnis zur Weiterveräußerung besteht nicht, wenn sich der Unternehmer in Zahlungsverzug befindet, Antrag auf Eröffnung des Insolvenzverfahrens gestellt ist, oder er die Zahlung einstellt. Die uns vom Unternehmer im Voraus abgetretenen Forderungen beziehen sich bei Bestehen eines Kontokorrentverhältnisses mit seinem Abnehmer auch auf den anerkannten Saldo sowie im Fall der Insolvenz des Abnehmers auf den dann vorhandenen "kausalen" Saldo. Soweit der Unternehmer ein Recht zur Einziehung der entsprechenden Forderungen hat, bleibt er hierzu auch nach der Abtretung ermächtigt. Unsere Befugnis, die Forderung selbst einzuziehen, bleibt hiervon unberührt. Wir verpflichten uns jedoch, die Forderung nicht einzuziehen, solange der Unternehmer seinen Zahlungsverpflichtungen aus den vereinnahmten Erlösen nachkommt, nicht in Zahlungsverzug gerät und insbesondere kein Antrag auf Eröffnung eines Insolvenzverfahrens gestellt ist oder Zahlungseinstellung vorliegt. Ist dies der Fall, können wir verlangen, dass der Unternehmer uns die abgetretenen Forderungen und deren Schuldner bekannt gibt, alle zum Einzug erforderlichen Angaben macht, die dazugehörigen Unterlagen aushändigt und den Schuldnern (Dritten) die Abtretung mitteilt.

Für den Fall, dass die von dem Unternehmer im Rahmen der Weiterveräußerung der Vorbehaltsware geschlossenen Verträge unwirksam oder nichtig sein sollten, tritt der Unternehmer bereits jetzt die ihm anstelle der abgetretenen vertraglichen Ansprüche zustehenden gesetzlichen Ansprüche, insbesondere Bereicherungsansprüche, in demselben Umfang an uns ab. Wir nehmen die Abtretung an.

7. Die Verarbeitung oder Umbildung der Kaufsache durch den Unternehmer wird stets für uns vorgenommen. Verarbeitet der Unternehmer unsere Vorbehaltsware mit anderen, uns nicht gehörenden Gegenständen, erwerben wir das Miteigentum an der neuen Sache im Verhältnis des Wertes der Kaufsache (Faktura-Endbetrag, einschließlich Mehrwertsteuer) zu den anderen verarbeiteten Gegenständen zur Zeit der Verarbeitung.

Wird die Kaufsache mit anderen, uns nicht gehörenden Gegenständen untrennbar verbunden, vermengt oder vermischt, so erwerben wir das Miteigentum an der neuen Sache im Verhältnis des Wertes der Kaufsache (Faktura-Endbetrag, einschließlich Mehrwertsteuer) zu den anderen verbundenen, vermengten, vermischten Gegenständen zum Zeitpunkt der Verbindung, Vermengung oder Vermischung. Erfolgt die Verbindung, Vermengung oder Vermischung in der Weise, dass die Sache des Unternehmers als Hauptsache anzusehen ist, gilt als vereinbart, dass der Unternehmer uns anteilmäßig Miteigentum überträgt.



Im Übrigen gilt für die durch Verarbeitung, Verbindung, Vermengung oder Vermischung entstehende neue Sache das Gleiche wie für die unter Eigentumsvorbehalt gelieferte Kaufsache, insbesondere Ziffer 6 vorstehend.

8. Der Unternehmer verwahrt das so entstandene Alleineigentum oder Miteigentum für uns. Der Unternehmer haftet für eigenes vorsätzliches und fahrlässiges Verhalten ebenso für das seiner gesetzlichen Vertreter und der Personen, deren er sich zur Erfüllung seiner Verbindlichkeiten bedient.
9. Wir verpflichten uns, uns zustehende Sicherheiten auf Verlangen des Unternehmers insoweit freizugeben, als der realisierbare Wert unserer Sicherheiten die zu sichernden Forderungen um mehr als 10 % übersteigt; die Auswahl der freizugebenden Sicherheiten obliegt uns.

## VII.

### Gefahrübergang

Die Gefahr des zufälligen Untergangs und der zufälligen Verschlechterung der Ware geht mit der Übergabe, beim Versandkauf mit der Auslieferung der Ware an den Spediteur, den Frachtführer oder die sonst zur Ausführung der Versendung bestimmte Person oder Anstalt auf den Unternehmer über. Der Übergabe steht es gleich, wenn der Unternehmer im Verzug der Annahme ist. Befindet sich der Unternehmer in Annahmeverzug, haften wir nur für Vorsatz und grobe Fahrlässigkeit.

## VIII.

### Mängelhaftung, Schadenersatzansprüche

1. Voraussetzung für die Mängelrechte des Unternehmers ist, dass dieser den in § 377 HGB geregelten Untersuchungs- und Rügeobliegenheiten ordnungsgemäß nachgekommen ist. Für die Rechtzeitigkeit der Rüge genügt die rechtzeitige Absendung. Den Unternehmer trifft die volle Beweislast für sämtliche Anspruchsvoraussetzungen, insbesondere für den Mangel selbst, für den Zeitpunkt der Feststellung des Mangels und für die Rechtzeitigkeit der Mängelrüge. Für nicht rechtzeitig gerügte Mängel haften wir nicht.
2. Rechtzeitige Beanstandungen werden von unserer Qualitätskontrolle geprüft.
3. Soweit ein Mangel der Kaufsache vorliegt, ist der Unternehmer nach seiner Wahl berechtigt, Nacherfüllung entweder in Form einer Mangelbeseitigung oder in Form der Lieferung einer neuen mangelfreien Sache zu verlangen. Die zum Zwecke der Nacherfüllung erforderlichen Aufwendungen, insbesondere Transport-, Wege-, Arbeits- und Materialkosten werden von uns getragen, sofern sich die Kosten nicht dadurch erhöhen, dass die Kaufsache nach einem anderen Ort als dem Erfüllungsort verbracht worden ist. Wir sind berechtigt, die Art der gewählten Nacherfüllung zu verweigern, wenn sie nur mit unverhältnismäßigen Kosten möglich ist und die andere Art der Nacherfüllung ohne erhebliche Nachteile für den Unternehmer bleibt. Wenn wir zum Zwecke der Nacherfüllung eine mangelfreie Sache liefern, können wir von dem Unternehmer Rückgewähr der mangelhaften Sache nach Maßgabe der §§ 346, 348 BGB verlangen. Ersetzte Teile werden unser Eigentum. Der Unternehmer muss uns Gelegenheit zur Untersuchung oder zur schriftlichen Stellungnahme geben, bevor er unsere Ware aus-

baut. Sind wir zur Nachbesserung oder mangelfreien Ersatzlieferung nicht in der Lage, kann der Unternehmer unter Ausschluss aller weiteren Ansprüche vom Vertrag zurück-treten oder eine angemessene Preisherabsetzung fordern.

Für normale Abnutzung haften wir nicht. Unsere Gewährleistung setzt voraus, dass die Ware sachgemäß behandelt wurde.

4. Der Anspruch auf die Leistung ist ausgeschlossen, sobald der Unternehmer statt der Leistung Schadenersatz verlangt hat.
5. Wir haften nach den gesetzlichen Bestimmungen, sofern der Unternehmer Schadenersatzansprüche geltend macht, die auf Vorsatz oder grober Fahrlässigkeit, einschließlich von Vorsatz oder grober Fahrlässigkeit unserer gesetzlichen Vertreter oder Erfüllungsgehilfen, beruhen. Soweit uns keine vorsätzliche oder grob fahrlässige Vertragsverletzung vorgeworfen wird, ist die Schadenersatzhaftung auf den vorhersehbaren, typischerweise eintretenden Schaden begrenzt. Wir haften nach den gesetzlichen Bestimmungen, sofern wir schuldhaft eine wesentliche Vertragspflicht verletzen. In diesem Falle ist die Schadenersatzhaftung auf den vorhersehbaren, typischerweise eintretenden Schaden begrenzt. Wir haften nicht bei lediglich leicht fahrlässiger Verletzung unwesentlicher Vertragspflichten. Soweit den Unternehmer ein Anspruch auf Ersatz des Schadens statt der Leistung zusteht, ist unsere Haftung auch im Rahmen von vorstehender Ziffer 3 auf Ersatz des vorhersehbaren, typischerweise eintretenden Schadens begrenzt. Die Haftung wegen schuldhafter Verletzung des Lebens, des Körpers oder der Gesundheit bleibt unberührt. Dies gilt auch für die zwingende Haftung nach dem Produkthaftungsgesetz.
6. Soweit vorstehend nichts Abweichendes geregelt ist, ist die Haftung im Übrigen ausgeschlossen. Soweit unsere Haftung ausgeschlossen oder beschränkt ist, gilt dies auch für die persönliche Haftung unserer gesetzlichen Vertreter oder Erfüllungsgehilfen.
7. Die Verjährungsfrist für Mängelansprüche beträgt ein Jahr ab Ablieferung der Ware. Unsere Haftung nach dem Produkthaftungsgesetz bleibt unberührt.

## IX.

### Anwendbares Recht, Erfüllungsort, Gerichtsstand

1. Es gilt das Recht der Bundesrepublik Deutschland. Die Geltung des UN-Kaufrechts ist ausgeschlossen.
2. Erfüllungsort und ausschließlicher Gerichtsstand für alle Streitigkeiten, gleich aus welchem Rechtsgrund, auch aus Wechsel oder Schecks, ist unser Geschäftssitz. Wir haben das Recht, auch am Sitz des Unternehmers zu klagen.

## X.

### Schlussbestimmungen

Sollten einzelne Bestimmungen des Vertrags mit dem Unternehmer einschließlich dieser Allgemeinen Geschäftsbedingungen ganz oder teilweise unwirksam sein oder werden, wird hierdurch die Gültigkeit der übrigen Bestimmungen nicht berührt. Die ganz oder teilweise unwirksame Regelung soll durch eine Regelung ersetzt werden, deren wirtschaftlicher Erfolg dem der unwirksamen Regelung möglichst nahe kommt.

# General Sale and Delivery Conditions

## Bremi Fahrzeug-Elektrik GmbH + Co. KG

### I.

#### General Regulations – Scope of Application

1. The following general business regulations shall apply to all present and future business relationships into which we enter with contractors, pursuant to Section 310, Paragraph 1 of the German Civil Code (BGB). This shall also apply where no express reference is made to the same in subsequent transactions. Divergent, contrasting or supplementary general business regulations of the Company shall not be incorporated into contracts even when known, unless we have expressly approved the application of the same in writing. The performance of a contract by ourselves shall not replace this written acknowledgement.
2. We unconditionally reserve our rights of exploitation of property and copyrights with regard to illustrations, drawings, calculations and other documents (hereafter, the "Documents"). The Documents may only be made available to third parties with our prior written consent, and if we are not awarded a contract, shall immediately be returned to us on demand. Clauses 1 and 2 shall correspondingly apply for the Company's documents. By way of exception, the documents may nevertheless be made available to such third parties, for which we have been authorised to assign deliveries.
3. Our offers are subject to confirmation and are non-binding in so far as there are no further consequences of the acknowledgement of the contract. With the order, the Company shall declare its contractual offer to be binding. We reserve the right to decline the order, for example, after checking the creditworthiness of the Contractor. Furthermore, we shall be authorised to accept the offer contained in the order within 14 days, through the delivery of an order confirmation or the dispatch of the ordered goods to the purchaser within this deadline. Our order confirmation shall be decisive for the content of the delivery contract. All agreements, in particular, the assumption of guarantees or financing risks, which are agreed between ourselves and the Company for the purpose of executing a contract, shall be set forth in this contract in writing.
4. The contract shall be concluded subject to the provision that we shall not carry out deliveries either in part or in full, in the event that supplies fail to match specifications or rules through no fault of our own. In the event that supplies are unavailable or only partially available, the Company shall immediately be informed of the same and the consideration for the order immediately reimbursed.
5. Orders that have been confirmed by ourselves may not be cancelled by the Company, unless we agree the same in writing on an exceptional basis. In such a case, we may demand an indemnity, the amount of which shall not exceed the contractual consideration of the Company.
6. We reserve the right to make changes to the construction and form until the delivery, albeit ensuring, while considering our own interests, that the interests of the Company are not affected in an unacceptable way.
7. The rights of the Company arising from the Contract shall only be transferable with our prior agreement.

### II.

#### Delivery and Receipt

1. The Company shall release us with regard to the products manufactured according to its demands, specifications, etc. from all claims that third parties may make against us or against a company associated with ours on grounds of industrial property rights, copyrights, brands etc. In so far as we have concerns about these, we shall be obliged to draw the attention of the Company to them, but have no independent duty of scrutiny. The same shall apply, if the Company uses our products without our agreement in such a way that the rights of third parties may be infringed.
2. In so far as it does not already arise from the nature of the obligation, e.g. a subsequent delivery contract, we shall be authorised to make partial deliveries, when the receipt of the same is acceptable to the Company.

### III.

#### Prices and Payment Conditions

1. In so far as our offer or our written order confirmation does not specify otherwise, our prices shall be understood as being denominated in Euros ex works, excluding packaging and insurance (NB: duly executed packaging shall be the responsibility of the seller. Packaging costs shall be agreed by the parties. The Company shall bear transport costs where the products are delivered to a location other than the place of performance). Special packaging requests by the Company shall be notified to us in writing as soon as possible and at latest, two weeks before the delivery or shipping deadline. Pallets and similar shipping material which is expressly distinguished in the invoice as loaned packaging material are to be returned in an appropriate and undamaged condition with carriage paid.
2. Official Value Added Tax is not included in our prices, with the legal amount of the same identified separately on the invoice on the day that it is issued.
3. Our invoices shall be payable within 30 days on a net basis and without deductions. Where these are paid within 14 days of the invoice date, the Company shall be authorised to deduct 2% from the net value of the products. For cashless payments, and notably transfers, the effective deadline for the outstanding payment in question shall not be that of the carrying out of the necessary transaction but the date on which the outstanding amount is received into our account. Means of payment other than cash or bank transfers to the accounts indicated by ourselves shall only be accepted by written agreement and as conditional payment. All payments shall be made net of expenses. In the event of default, late payment interest shall accrue at the legal rate of 800 basis points above the relevant base rate, as the minimum claim. We hereby reserve the right to enforce claims for injuries due to delayed performance.
4. The withholding of payments by the Company shall be excluded where counterclaims arise from another contractual relationship. If the counterclaims arise from the same contractual relationship, the withholding of payments shall

only be permitted where these relate to counterclaims that are determined to be legally binding, unchallenged or acknowledged by ourselves.

5. Likewise, the Company shall only be entitled to make offsetting payments, when its counterclaims are determined to be legally binding, unchallenged or acknowledged by ourselves.
6. The Company declares that it agrees to our offsetting outstanding amounts due to it against outstanding amounts due to us, even when the due dates of the reciprocal outstanding amounts are different.  
We reserve the right to change our prices correspondingly, when costs increase or decrease after the conclusion of the contract, in particular due to changes in raw materials prices. These shall be demonstrated to the Company on request. Changes in prices may only be made to compensate the relevant changes in costs and shall therefore be restricted to the cost-dependent portion of the overall price.
7. Pro-rata costs of tools shall, unless otherwise agreed in writing, be paid immediately without deductions, with 50 % due when the invoice is issued and 50% when reference samples are submitted.
8. Partial deliveries shall be paid separately by the deadlines indicated in point 3. In the event that the Company does not pay in timely fashion, we may suspend the further completion of the order or demand the agreed price against the provision of the named quantity of product. The same shall apply for stand-by contracts, where the Company does not retrieve the products in regular fashion. For products purchased on a stand-by basis, the Company shall, in the absence of another written agreement, have collected the purchased goods in full within six months. Stand-by requests must be received by us at latest six weeks before the delivery deadline.

#### IV.

##### Credit basis

1. A precondition for deliveries is the creditworthiness of the Company. In the event that we receive information following the conclusion of the contract suggesting that the granting of a credit for the amount arising from the contract will not be automatic, or if events occur which cast doubts on the same, in particular, if there is a notable deterioration in the financial situation (foreclosure, bankruptcy, insolvency, liquidation, change of ownership), we shall be authorised to demand appropriate prepayments or sureties or payment in cash, without concern for conflicting previous agreements.
2. Under the same preconditions, we shall be authorised after delivery to the Company to inspect the warehouses of the same, and to secure goods under retention of title on a provisional basis until payment is made in cash, without concern for conflicting previous agreements. The Company shall bear transport and temporary storage costs.

#### V.

##### Delivery Times

1. Compliance with agreed delivery deadlines shall presuppose that the Company submits all the necessary documents, required authorisations and approvals, in particular of plans, and complies with the agreed payment conditions and other obligations. In the event that these preconditions are not met in timely fashion, the delivery deadlines shall be suitably extended, with our reserving the right to object on grounds of failure of contractual performance and to assert claims to our right of retention. The above shall not apply where we are responsible for the delay.
2. The agreed delivery deadline shall be extended, regardless of our rights, due to default, for the period for which there is a lasting or suspensive objection, and in particular, while the Company remains in default of its obligations arising from this or from another contract.
3. The delivery deadline shall be suitably extended in the event of measures in the context of lawful labour disputes, in particular strikes and lockouts within our own factory, or in third-party factories regardless of the legality of the industrial dispute measures, in so far as we are unaffected by any blame for acceptance, precautions or preventive measures, and additionally, by the occurrence of unforeseen events such as mobilisation, war, blockades, bans on exports and imports, in particular, legal or government instructions, shortages of raw materials or fuel, fire or closure to traffic, acts of God, in so far as such obstacles have a demonstrable influence on the completion or delivery of the objects of the delivery and occur to us, to a supplier or to a subcontractor and remain beyond our control.
4. In any event of partial or complete discontinuation of deliveries from sources of supply, Bremitz are under no obligation whatsoever to purchase products from third parties. Our contractual partners do not have the right to purchase from third parties and/or to claim damages as a result of possible non-compliance with lead times caused by events within or beyond Bremitz's control.
5. The delivery deadline shall have been observed if by it, the products have left our plant in Dömitz, or we have given notice that they are ready for delivery.

We shall be liable pursuant to legal provisions, in so far as the underlying purchase contract is a fixed contract pursuant to Section 286, Para. 2, Item 4 of the German Civil Code (BGB) or Section 376 of the German Commercial Code (HGB). We shall also be liable pursuant to legal provisions, in so far as the Company is authorised as a consequence of a delayed delivery for which we are responsible, to claim that its interest in the subsequent fulfilment of the contract has ceased. We shall be further liable, pursuant to legal provisions, in so far as the delayed delivery is due to a deliberate or grossly negligent breach of contract on our part. In so far as the delayed delivery is not due to a deliberate or grossly negligent breach of contract on our part, our liability for damages shall be limited to the foreseeable, naturally arising injuries. The fault of our representative or vicarious agent shall be attributed to us.

We shall also be liable pursuant to legal provisions, in so far as the delayed delivery for which we are responsible is due to the culpable violation of a significant contractual obligation; in this case, however, our liability for damages shall be limited to the foreseeable, naturally arising injuries.

6. If the Company is in default on a debt or in acceptance or has culpably violated other obligations of cooperation, we shall be authorised to demand compensation for the injuries sustained in this respect, including any additional expenditures. The Company shall be allowed to produce evidence that we have not suffered any injuries at all, or that these are significantly lower than the loss allowance. This shall also apply to the case that the delivery of the object of the purchase is delayed on the wishes of the Company. We reserve the right to press further claims.
7. In so far as the Company is in default on a debt or in acceptance or has culpably violated other obligations of cooperation, or has postponed the delivery of the product at its own wish, the risk of the accidental decay or deterioration of the purchase shall be shifted to the Company as of the time when the same party defaults on debts or in acceptance, has failed to perform the outstanding obligation of cooperation or has postponed the delivery of the product at its own wish.

## VI.

### Retention of Title

1. We shall reserve ownership of the sale object until all payments arising from the business relationship have been received. In the event that there is a current account relationship, the provision shall refer to the recognised balance. This shall include, in addition to the complete payment of the full purchase price, including value added tax, any interest and other associated costs, such as freight costs to be borne by the Company.
2. While our retention of title is in effect, the Company shall be obliged to handle the sale object with care. It shall be further obliged to insure the same against fire, flooding and theft at replacement value. In so far as maintenance and inspection work is necessary, the Company shall undertake these in timely fashion at its own expense.
3. In the event of distraints or other third-party interventions, the Company must oppose these and report the same to us immediately by the fastest possible means, so that we may file a suit pursuant to Section 771 of the German Civil Procedure Code (ZPO) if necessary. In so far as the third party is not in a position to compensate us for the judicial and extrajudicial costs of proceedings, pursuant to Section 771 of the German Civil Procedure Code (ZPO), the Company shall be liable for the financial loss accruing to us. The Company shall not be authorised to make assignments as security, pledges and other uses of the goods to which we retain title which place our rights at risk. Where the Company's behaviour is contrary to the contract, particularly for payment delays, we shall be authorised to reclaim the sale object. Our reclaiming of the sale object shall constitute a withdrawal from the contract. After reclaiming the sale object, we shall be authorised to sell the same, with the proceeds to be offset against the obligations of the Company after the deduction of appropriate costs of realisation.
4. If the Company delays the fulfilment of its obligations in part or in full, the entire remaining balance plus late payment interest shall immediately fall due. We shall furthermore be authorised to withdraw from all contracts that have not yet been executed, or to refrain from all deliveries and other services in all contracts on account of the claims due to us. The

Company may avoid this right of retention by arranging the issue of an absolute undated guarantee by a major German bank, German savings or cooperative bank for the full amount of the outstanding claims.

5. The Company shall be obliged to store and distinguish our goods under retention of title in a separate location.
6. The Company shall be justified in selling on the purchase object in a regular business transaction; it shall nevertheless immediately assign all of our claims, including accessory rights and sureties for the amount of the final amounts of the invoices (including value added tax) arising from the further assignment to its client or to a third party, and this independently of whether or not the purchase object has been sold on without or after further processing. We shall accept the transfer. An authorisation for the further disposal shall not be granted when the Company has defaulted on payments, has filed for bankruptcy or halts payment. Our claims assigned by the Company on a prior basis shall also relate, in the event that there is a current account relationship with its customer, to the acknowledged balance, as in the case of insolvency of the customer, to the "causal" balance which is then available. In so far as the Company is entitled to collect the corresponding claims, it shall remain authorised to do so even after the assignment. Our authorisation to collect the claims ourselves shall remain unaffected by the same. We shall nevertheless undertake not to collect the claims for as long as the Company meets its payment obligations from the collected proceeds, does not default on payment, and in particular, does not file for bankruptcy or halt payments. In this case, we may demand that the Company gives us notice of the assigned claims and the liable parties, provides us with all the information necessary for collection, surrenders the associated documents and informs the debtors (third parties) of the assignment.

In the case that the contracts concluded by the Company in the context of the further disposal of the retained goods are found to be ineffective or invalid, the Company shall immediately assign to us the due legal claims in the place of the assigned contractual claims, most notably claims based on unfair enrichment to the same extent. We shall accept the assignment.

7. The processing or reorganisation of the sale object by the Company shall always be carried out for us. If the Company processes our retained goods with other objects that do not belong to us, we shall acquire joint ownership of the new product in relation to the ratio of the sale object (final invoice amount, including value added tax) to the other processed objects at the time of processing.

If the processed goods are indissociably joined with objects not belonging to us, we shall acquire joint ownership of the new product in relation to the ratio of the sale object (final invoice amount, including value added tax) to the other joined, blended or mixed objects at the time of association. If the joining, blending or mixing is carried out in such a way that the product of the Company is seen to be the main item, it shall be considered as agreed that the Company shall assign us joint ownership on a proportional basis. Furthermore, the same terms shall apply to the new object arising through processing, joining, blending or mixing as to the purchase good delivered under title of retention, most notably the above item 6.

8. The Company shall safeguard the sole or joint property for us. The Company shall also assume liability for its own deliberate and negligent behaviour, as well as for that of its legal

representative and for the persons who assist it in fulfilling its obligations.

9. We shall undertake to release the sureties due to us at the demand of the Company, in so far as the realisable value of the same exceed the guaranteed claims by more than 10 %; the selection of the sureties to be released shall be incumbent on us.

## VII.

### Transfer of Risk

The risk of the accidental decay or deterioration of the goods shall migrate to the Company for mail-order purchases with the delivery to the carrier, the freight forwarder or other persons or entities defined for the execution of the shipping. The same consequences shall arise if the Company is in default in accepting the delivery. If the Company is in default in this way, we shall only be liable for malicious intent and gross negligence.

## VIII.

### Liability for Defects, Claims for Damages

1. A precondition for the warranty rights of the Company is that the same party has performed the obligations of investigation and objection set forth in Section 377 of the German Commercial Code (HGB) in proper fashion. Timely dispatch shall be sufficient for the timeliness of the objection. The Company shall bear the full burden of proof for conditions of entitlement, in particular for the defect itself, for the time of determination of the defect and for the timeliness of the objection. We shall not be liable for objections to defects that are not communicated in timely fashion.
2. Timely objections shall be checked by our Quality Control department.
3. In so far as there is a defect in the sale object, the Company shall be authorised, as it chooses, to demand subsequent performance in the form either of the correction of the defect or the delivery of a new defect-free product. Expenditure incurred for the purpose of subsequent performance, notably transport, tolls, work and material costs shall be borne by us, in so far as the costs do not increase due to the fact that the sale object has been taken from a place other than the place of performance. We are authorised to reject the chosen form of subsequent performance, when it is only possible at disproportionate cost and the other forms of subsequent performance are without significant disadvantages for the Company.

When we deliver a defect free product for the purpose of subsequent performance, we may demand the return of the defective product from the Company pursuant to Sections 346 and 348 of the German Civil Code (BGB).

Replaced parts shall become our property. The Company shall give us the opportunity to investigate or issue a written position before it dismantles our products. If we are not in a position to amend the product or deliver a defect-free replacement, the Company may, on excluding all further claims, withdraw from the contract or demand a suitable price reduction.

We shall not be liable for normal wear and tear. Our guarantee states that requires that goods are handled appropriately.

4. Performance claims shall be excluded as soon as the Company has demanded compensation for damages instead of the performance.
5. We shall be liable pursuant to the provisions of the law, in so far as the Company makes valid claims for compensation resting on malicious intent or gross negligence, including that of our legal representatives or assistants with execution. In so far as we are not accused of any breach of contract due to malicious intent or gross negligence, the liability for compensation shall be limited to foreseeable, naturally arising injuries.

We shall be liable pursuant to the provisions of the law, in so far as we culpably breach a significant contractual obligation. In this case, the liability for compensation shall be limited to foreseeable, naturally arising injuries. We shall not be liable for only mildly negligent breaches of insignificant contractual obligations. In so far as the Company claims compensation for injuries instead of performance, our liability shall also be limited with regard to the previous point 3 to foreseeable, naturally arising injuries.

Liability for culpable injury to life, body or health shall remain unaffected. This shall also apply to compulsory liability according to the Product Liability Law.

6. In so far there are no exceptions in the above provisions, remaining liability is excluded. In so far as our liability is excluded or restricted, this shall also apply to the personal liability of our legal representatives or vicarious agents.
7. The limitation period for claims for defective goods shall be one year from the delivery of the products. Our liability pursuant to the product liability law shall remain unaffected.

## IX.

### Applicable Law, Place of Performance, Jurisdiction

1. This contract shall be governed by the laws of the Federal Republic of Germany. The validity of UN Purchase Law is hereby excluded.
2. The Place of Performance and exclusive Jurisdiction for all disputes, regardless of the legal grounds, including currency or cheques, shall be our registered office. We shall also have the right to file claims at the registered office of the Company.

## X.

### Final Provisions

In the event that individual provisions of the contract with the Company, including these general business conditions are or become ineffective, whether in part or in whole, the same shall not affect the validity of the other provisions. The partly or wholly ineffective provision shall be replaced by another, which comes as close as possible to the commercial effect of the ineffective one.



BREMI Fahrzeug-Elektrik GmbH + Co. KG  
Grüner Weg 1  
19303 Dömitz (Germany)

Fon +49 (0)38758 304 0  
Fax +49 (0)38758 304 13  
Mail [info@bremit.de](mailto:info@bremit.de)



[www.bremit.de](http://www.bremit.de)

DO 545