

ARSAUTO srl



50

1958-2010
oltre cinquanta
anni di esperienza
tre generazioni

Veicoli industriali e commerciali
Industrial and commercial vehicles

ARSAUTO E' UN MARCHIO: ARSAUTO IS A BRAND BY:



Imposta di bollo
assolto mediante
versamento in c/c
postale ai sensi
dell'art. 3 del D.P.R.
30.12.1982 N. 955



Ministero dei Trasporti

Dipartimento per i Trasporti Terrestri e il Trasporto Intermodale
Direzione Generale Territoriale Centro Nord
Centro Superiore Ricerche e Prove Autoveicoli e Dispositivi
ROMA

CERTIFICATO N.
CERTIFICATE N.

023/08

- Visti gli articoli 75, 77, 107, 109 e 114 del decreto legislativo 30 aprile 1992, n.285, e successive modificazioni ed integrazioni;
- Visto il decreto 25 novembre 1997, pubblicato sulla Gazzetta Ufficiale del 28 novembre 1997, n. 278 – serie generale;
- Visto il verbale n. 023/08 del 6/05/2008 della commissione ispettiva, designata per l'effettuazione del sopralluogo;

- Having regard to the legislative decree 30th April 1992, n. 285 and his following updates and integrations, and in particular Article 75, Article 77, Article 107, Article 109 and Article 114 thereof;
- Having regard to the decree 25th November 1997, published on the Official Journal of 28th November 1997, no. 278 – general series;
- Acting in accordance with the report n. 023/08 of 6/05/2008 of the committee appointed to carry out the inspection;

Il costruttore
the manufacturer

ARSAUTO s.r.l.

per l'impianto di produzione sito in
for the manufacturing plant located in

C.so Mandelli,10 10070 Cafasse (TO)

e per il prodotto
and for the product

Specchi retrovisori

E' RITENUTO IDONEO ALLA PRODUZIONE IN SERIE
IS QUALIFIED FOR THE PRODUCTION IN SERIES

Roma, 6/05/2008

Il presente certificato è valido due anni.
This certificate is valid two years.



IL DIRETTORE / THE DIRECTOR
(Dott. Ing. Michele Ciaccia)

ING. DIRETTORE COORD.
Dott. Ing. Giovanni Riccardi

**PRODOTTO
DEL MESE**

Una questione di **Sicurezza**

Arsauto S.r.l. di Cafasse, da più di trent'anni azienda leader nel settore nella produzione di specchi retrovisori, ha messo a punto il sistema Guardavanti, che garantisce la piena visibilità nelle immediate vicinanze della cabina, anche per i veicoli immatricolati prima del 2007

La normativa europea 2005/27CE, prevede che i veicoli immatricolati dal 26/01/2007 siano dotati di un dispositivo per la visione anteriore e laterale alla cabina, sul lato opposto a quello di guida. Non rientrano, quindi, nell'obbligo i mezzi circolanti antecedenti al 2007, probabilmente perché non si sapeva bene dove montarli, visto che non è consentito forare la carrozzeria. Eppure la piena visibilità durante la guida rimane un fatto di sicurezza per tutti, dall'autista, al camion, agli utenti della strada in generale. Può capitare, infatti, che la visuale dalla cabina non consenta di vedere alcuni ostacoli, dal pedone che attraversa improvvisamente, al muretto basso, all'auto troppo accostata a destra; in città come sulle tangenziali o negli svicoli delle autostrade. Un semplice urto può causare, comunque, danni alla carrozzeria o la rottura del gruppo ottico anteriore, che deve essere immediatamente sostituito, tra l'altro con esborsi notevoli, e, spesso, con difficoltà di reperimento.

◆ **Guardavanti**

Arsauto propone il sistema Guardavanti, che garantisce la piena visibilità nelle immediate vicinanze della cabina, anche quando l'eventuale ostacolo non sarebbe normalmente visibile dal posto di guida. Pensato e realizzato per tutti i modelli di camion prodotti prima del 2007, Iveco, Astra, Volvo, Scania, MAN, DAF, Mercedes



L'eliminazione della zona cieca anteriore permette di evitare ostacoli altrimenti invisibili per l'autista, aumentando notevolmente la sicurezza dei pedoni durante le manovre e nei percorsi urbani



I Guardavanti Arsauto si installano facilmente e in pochi minuti, utilizzando i filetti e la viteria già presenti sulla cabina e sono in vendita a 120 euro circa

e Renault Trucks, il nuovo specchio retrovisore Arsauto si monta utilizzando i fori e i filetti esistenti per l'installazione della visiera parasole e rispetta tutte le direttive attualmente in vigore. Gli specchi retrovisori Arsauto sono regolarmente omologati dal Centro Prove di Roma del ministero delle Infrastrutture e dei Trasporti italiano, nel pieno rispetto delle direttive attualmente in vigore, e sono stati sottoposti a tutti i test per la verifica della copertura dei campi visivi per ogni modello di veicolo per il quale sono stati realizzati. Tutti i prodotti dell'Azienda piemontese, inoltre, vengono prodotti interamente in Italia, con componenti provenienti unicamente dalla Comunità Europea ed è in preparazione un sistema che permetterà l'installazione dei Guardavanti anche sui veicoli non dotati di parasole.



ARSAUTO s.r.l.

INDICE VEICOLI INDUSTRIALI INDUSTRIAL VEHICLES INDEX

DAF	1 - 3
IVECO - ASTRA	4 - 30
MAN	31 - 36
MERCEDES	37 - 43
NISSAN	44
RENAULT	45 - 49
SCANIA	50 - 53
VOLVO	54 - 59
UNIVERSAL	60 - 64

INDICE VEICOLI COMMERCIALI COMMERCIAL VEHICLES INDEX

FIAT - OM	65 - 75
CITROEN	68 - 75
PEUGEOT	68 - 75
MERCEDES	76



ARSAUTO s.r.l.

**VEICOLI INDUSTRIALI
INDUSTRIAL VEHICLES**

Tutti i dispositivi retrovisori sono omologati presso il Centro Prove del Ministero dei Trasporti Italiano, prodotti in Italia, con componenti provenienti dalla UE.

All the rear view mirrors have been homologated by the Test Center of Italian Ministry of Transport, produced in Italy, with UE materials.

Alle die Spiegel sind bei dem Testzentrum vom Italienische Ministerium fuer Verkehr getestet, mit Material von UE.

Tous les rétroviseurs sont homologués par le Centre des Epreuves du Ministère des Transports Italien, produit en Italie, avec matériels UE.



0966.1700

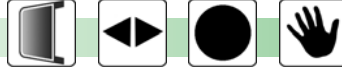

0966.1710



o.r. 1420104 1610186

0966.1730



o.r. 1425105 1610184



1036.07003

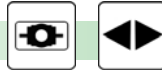

1036.07103



o.r. 1425109 1610190



0046.1000



o.r. 1425113

XF / CF



0944.17003



0944.17103



ALTERNATIVI ALL'ORIGINALE
ALTERNATIVE TO THE ORIGINAL ONE



1030.07003



1030.07103

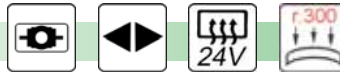

ALTERNATIVI ALL'ORIGINALE
ALTERNATIVE TO THE ORIGINAL ONE



0733.11003



INTERASSE 50mm / WHEELBASE 50mm

0733.11103



INTERASSE 50mm / WHEELBASE 50mm

ALTERNATIVI ALL'ORIGINALE
ALTERNATIVE TO THE ORIGINAL ONE



0737.11003



INTERASSE 100mm / WHEELBASE 100mm

0737.11103



INTERASSE 100mm / WHEELBASE 100mm

ALTERNATIVI ALL'ORIGINALE
ALTERNATIVE TO THE ORIGINAL ONE

XF



(0799.12003)					0799.10003 + 0958.12003	
0799.10003						
0958.12003						
(0799.12103)						0799.10103 + 0958.12103
0799.10103						
0958.12103						

CF



MODELLO CABINA BASSA
LOW CAB MODEL

(0742.12003)					0742.10003 + 0958.12003	
0742.10003						
0958.12003						
(0742.12103)						0742.10103 + 0958.12103
0742.10103						
0958.12103						



0905.1100

o.r. 4755582



mm 439x209

0905.1110

o.r. 4755870



mm 439x209

0905.1140



mm 439x209

0905.3100

o.r. 4723931



mm 439x209

0905.3110



mm 439x209

1065.0100

o.r. 4755585



mm 425x195

1065.0110

o.r. 93190915



mm 425x195

1065.0140



mm 425x195

0030.0000



mm 1000



0902.1100							mm 359x209
o.r. 4723931							
0902.1110							mm 359x209
o.r. 4788351 4741047							
0902.1140							mm 359x209
0902.3100							mm 359x209
o.r. 42344326							
0902.3110							mm 359x209
o.r. 42344895 98424110							
1059.0100							mm 345x195
o.r. 4723936							
1059.0110							mm 345x195
o.r. 93190916							
1059.0140							mm 345x195
0030.0000							mm 1000

FIAT IVECO -OM 50-50NC-60NC-60.10-79.13 MAGIRUS DEUTZ



0916.1100						mm 346x162	
o.r. 4723931							
0916.1110							mm 346x162
o.r. 4788351 4741047							
0916.1140							mm 346x162
0916.3100						mm 346x162	
o.r. 42344326							
0916.3110							mm 346x162
o.r. 42344895 98424110							
0030.0000						mm 1000	

**OM 50-55-60-65-70-75-80-90-100-190-260 FIAT 50NC-F9-F10-65F10-70F10-80NC-F13-90NC-100F13-100NC
FIAT UNIC FRANCIA 691 MAGIRUZ DEUTZ 90M 5.3**



0772.1100						LAMIERA/SHEET mm 354x162
o.r. 4697662 4995043						
1055.0100						
o.r. 4672587						

**FIAT 682N4-682T4-643-683-693-645N/N1-662N/N1 FIAT 100-110-160-619-639-684-697-300
OM 150-180 NC FIAT 170NC-170NT/25-33E-190NC-190NT**



0773.1100						LAMIERA/SHEET mm 354x199	
o.r. 4699450							
0773.1110							LAMIERA/SHEET mm 354x199
o.r. 8468220							
1056.0100						mm 342x187	
o.r. 4699453							
1056.0110						mm 342x187	
0030.0000						mm 1000	



0908.16303



mm 432x323

0908.36003

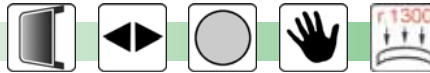

mm 432x323

0908.36103



mm 432x323

0908.36303

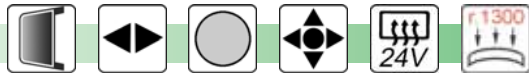

mm 432x323

o.r. 66800285



0036.1000



0036.3000



1010.06003



ATTACCO A MOLLA/SPRINGER CLAMP

1010.06103

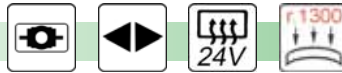

ATTACCO A MOLLA/SPRINGER CLAMP

o.r. 93160537

1013.06003



ATTACCO A GHIERA/RING CLAMP

1013.06103

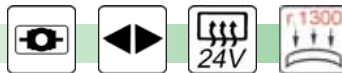

ATTACCO A GHIERA/RING CLAMP

o.r. 93156901

TURBOSTAR

**0960.31003**

o.r. 98424102 42345783

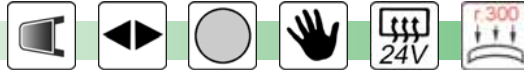
**0960.31103****0960.11003**

o.r. 42345784

**0960.11103****0959.31003**

o.r. 42345778

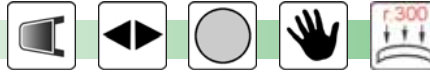
**0959.31103****0959.11003**

o.r. 42345780

**0959.11103****4013.1000****ATTUATORE / ACTUATOR**

**0924.37003**

o.r. 98472981 98473008

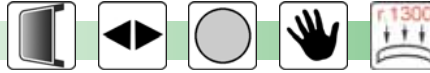

mm 455x215

0924.37103

o.r. 98472982 98473010

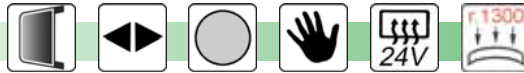

mm 455x215

0924.37303

o.r. 98472983 98473011

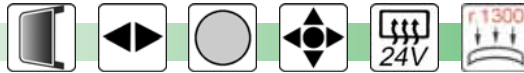

mm 455x215

**0037.3000**

o.r. 93171063

**1016.07003**

o.r. 93190981

**ATTACCO A MOLLA/SPRINGER CLAMP mm 440x200****1016.07103**

o.r. 93190976

**ATTACCO A MOLLA/SPRINGER CLAMP mm 440x200****1011.07003**

o.r. 93193162

**ATTACCO A GHIERA/RING CLAMP mm 440x200****1011.07103**

o.r. 93193198

**ATTACCO A GHIERA/RING CLAMP mm 440x200**

**0925.37003**

o.r. 98472976 98473005



mm 355x215

0925.37103

o.r. 98472977 98473006



mm 355x215

0925.37303

o.r. 98472979 98473007



mm 355x215

**0038.3000**

93190971

**1017.07003**

o.r. 93190983

**ATTACCO A MOLLA/SPRINGER CLAMP mm 340x200****1017.07103**

o.r. 93190970

**ATTACCO A MOLLA/SPRINGER CLAMP mm 340x200****1012.07003**

o.r. 93193200

**ATTACCO A GHIERA/RING CLAMP mm 340x200****1012.07103**

o.r. 93193197

**ATTACCO A GHIERA/RING CLAMP mm 340x200****4016.1000**

o.r. 93190972

**ATTUATORE / ACTUATOR****PER COPPE 0924-0925 / FOR HEADS 0924-0925**

**0926.37003**

o.r. 98472986



mm 188x214

0926.37103

o.r. 98472987 504132248

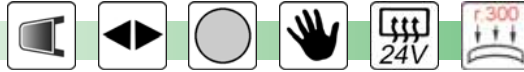

mm 188x214

0926.37303

o.r. 98472989 504132249

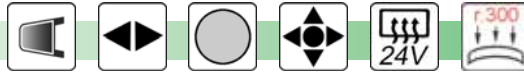

mm 188x214

**0040.3000**

o.r. 93190974

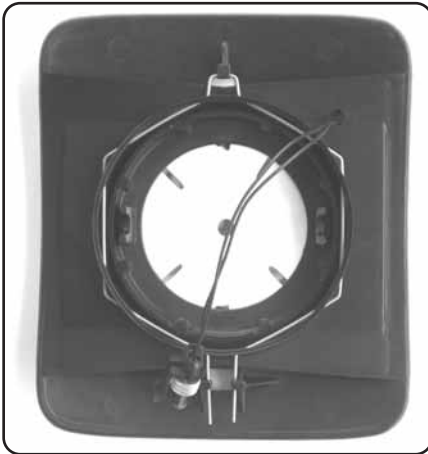
**1025.07003**

o.r. 93190982

**ATTACCO A MOLLA/SPRINGER CLAMP mm 170x197****1025.07103**o.r. 93190973
42548403**ATTACCO A MOLLA/SPRINGER CLAMP mm 170x197****1018.07003**

o.r. 29972254

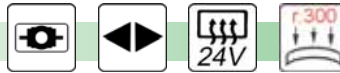
**ATTACCO A GHIERA/RING CLAMP mm 170x197****1018.07103**o.r. 93193199
29972253**ATTACCO A GHIERA/RING CLAMP mm 170x197****4025.1000**

o.r. 93190975

**ATTUATORE / ACTUATOR****PER COPPE 0926-0963 / FOR HEADS 0926-0963**

**0963.37003**

o.r. 504132242



mm 225x280

0963.37103

o.r. 504132243



mm 225x280

0963.37303

o.r. 504132244



mm 225x280

**1032.07003****ATTACCO A MOLLA/SPRINGER CLAMP mm 160x258****1032.07103**o.r. 93190984
42558713**ATTACCO A MOLLA/SPRINGER CLAMP mm 160x258****1033.07003**

o.r. 93139201

**ATTACCO A GHIERA/RING CLAMP mm 160x258****1033.07103**o.r. 93190960
98487460**ATTACCO A GHIERA/RING CLAMP mm 160x258**

(0818.12003)



0818.10003 + 0958.12003

0818.10003**0958.12003**

(0818.12103)



0818.10103 + 0958.12103

0818.10103**0958.12103**



0902.1100

o.r. 4723931



mm 359x209

0902.1110

o.r. 4788351 4741047



mm 359x209

0902.1140



mm 359x209

0902.3100

o.r. 42344326



mm 359x209

0902.3110

o.r. 42344895 98424110



mm 359x209

1059.0100

o.r. 4723936



mm 345x195

1059.0110

o.r. 93190916



mm 345x195

1059.0140



mm 345x195

0030.0000



mm 1000

EUROCARGO



0916.1100

o.r. 4723931



mm 346x162

0916.1110

o.r. 4788351 4741047



mm 346x162

0916.1140



mm 346x162

0916.3100

o.r. 42344326

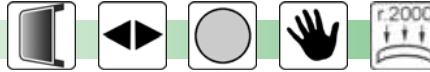

mm 346x162

0916.3110

o.r. 42344895 98424110



mm 346x162

0030.0000



mm 1000

EUROCARGO

**0924.37003**

o.r. 98472981

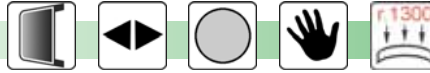

mm 455x215

0924.37103

o.r. 98472982

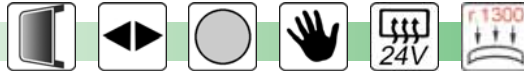

mm 455x215

0924.37303

o.r. 98472983

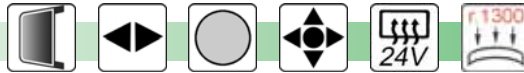

mm 455x215

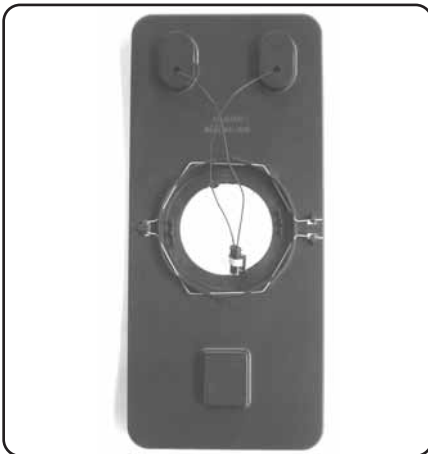
**0037.3000****1016.07003**

o.r. 93190981

**ATTACCO A MOLLA/SPRINGER CLAMP mm 440x200****1016.07103**

o.r. 93190976

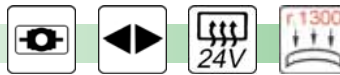
**ATTACCO A MOLLA/SPRINGER CLAMP mm 440x200****1011.07003**

o.r. 93193162

**ATTACCO A GHIERA/RING CLAMP mm 440x200****1011.07103**

o.r. 93193198

**ATTACCO A GHIERA/RING CLAMP mm 440x200**

**0925.37003**

o.r. 98472976



mm 355x215

0925.37103

o.r. 98472977



mm 355x215

0925.37303

o.r. 98472979



mm 355x215

**0038.3000****1017.07003**

o.r. 93190983

**ATTACCO A MOLLA/SPRINGER CLAMP mm 340x200****1017.07103**

o.r. 93190970

**ATTACCO A MOLLA/SPRINGER CLAMP mm 340x200****1012.07003**

o.r. 93193200

**ATTACCO A GHIERA/RING CLAMP mm 340x200****1012.07103**

o.r. 93193197

**ATTACCO A GHIERA/RING CLAMP mm 340x200****4016.1000****ATTUATORE / ACTUATOR****PER COPPE 0924-0925 / FOR HEADS 0924-0925**

**0960.31003**

o.r. 98424102 42345783

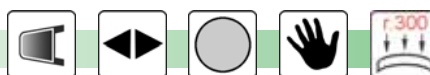
**0960.31103****0960.11003**

o.r. 42345784

**0960.11103****0926.37003**

o.r. 98472986

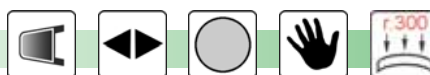
**0926.37103**

o.r. 98472987

**0926.37303**

o.r. 98472989

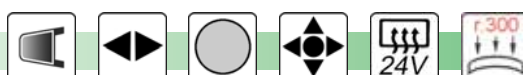
**0040.3000**

o.r. 93190974

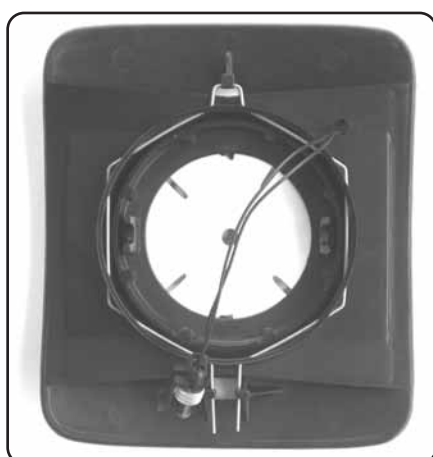
**1025.07003**

o.r. 93190982

ATTACCO A MOLLA/SPRINGER CLAMP mm 170x197**1025.07103**

o.r. 9319973

ATTACCO A MOLLA/SPRINGER CLAMP mm 170x197**1018.07003****ATTACCO A GHIERA/RING CLAMP mm 170x197****1018.07103**

o.r. 93193199

ATTACCO A GHIERA/RING CLAMP mm 170x197

**0959.31003**

o.r. 42345778

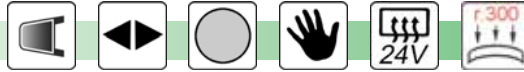
**0959.31103****0959.11003**

o.r. 42345780

**0959.11103****0963.37003**

o.r. 504132242

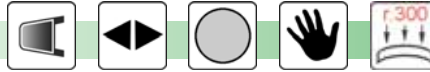

mm 225x280

0963.37103

o.r. 504132243

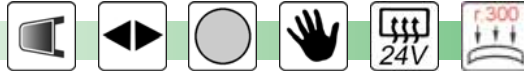

mm 225x280

0963.37303

o.r. 504132244



mm 225x280

**1032.07003****ATTACCO A MOLLA/SPRINGER CLAMP mm 160x258****1032.07103**

o.r. 93190984





**ATTACCO A MOLLA/SPRINGER CLAMP mm 160x258****1033.07003****ATTACCO A GHIERA/RING CLAMP mm 160x258****1033.07103**

o.r. 93190960

**ATTACCO A GHIERA/RING CLAMP mm 160x258****4025.1000****ATTUATORE / ACTUATOR****PER COPPE 0926-0963 / FOR HEADS 0926-0963**





EUROCARGO



(0818.12003)     **0818.10003 + 0958.12003**

0818.10003  





0958.12003    

(0818.12103)      **0818.10103 + 0958.12103**

0818.10103   





0958.12103     



(0744.12003)     **0744.10003 + 0958.12003**

0744.10003  

0958.12003    

(0744.12103)      **0744.10103 + 0958.12103**

0744.10103   

0958.12103     



1034.0600



1034.0610



o.r. 504197878



1035.0600



1035.0610



o.r. 504197879



(0759.12003)



0759.10003 + 0958.12003

0759.10003



0958.12003



(0759.12103)



0759.10103 + 0958.12103

0759.10103



0958.12103





1034.0600



1034.0610



o.r. 504197878



1035.0600



1035.0610



o.r. 504197879



(0818.12003)



0818.10003 + 0958.12003

0818.10003



0958.12003



(0818.12103)



0818.10103 + 0958.12103

0818.10103



0958.12103



N380



IVECO BUS

IVECO BUS



0824.351D

o.r. 93172323

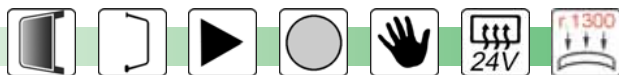

0824.353D

o.r. 93172539

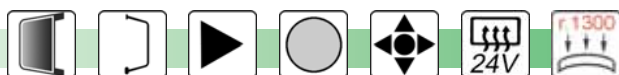

0823.301D

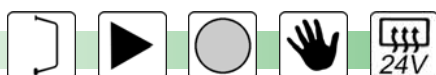

0823.303D

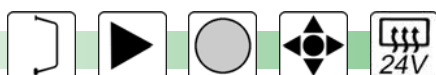

0824.351S

o.r. 93173324

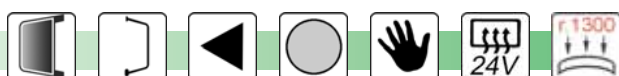

0824.353S

o.r. 93172540

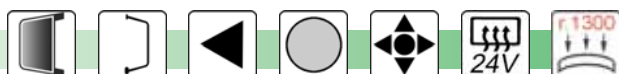

0823.301S

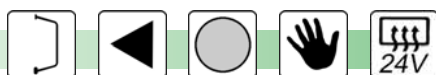

0823.303S

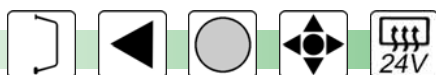

0924.37003

o.r. 98472981

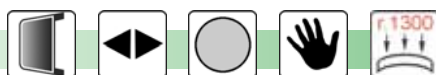

mm 455x215

0924.37103

o.r. 98472982



mm 455x215

0924.37303

o.r. 98472983

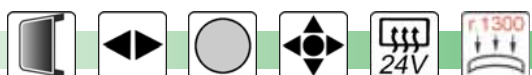

mm 455x215

N380

I
V
E
C
O
B
U
S

I
V
E
C
O
B
U
S



0037.3000

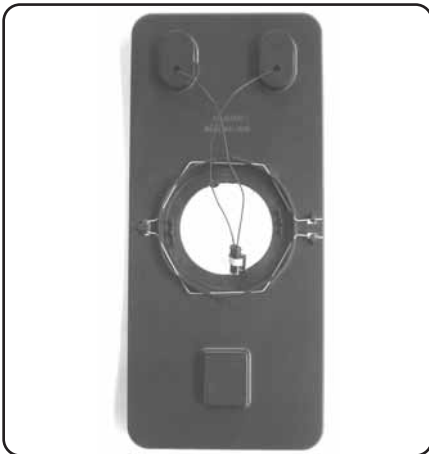

1016.07003



o.r. 93190981

ATTACCO A MOLLA/SPRINGER CLAMP mm 440x220

1016.07103



o.r. 93190976

ATTACCO A MOLLA/SPRINGER CLAMP mm 440x220

1011.07003



o.r. 93193162

ATTACCO A GHIERA/RING CLAMP mm 440x220

1011.07103

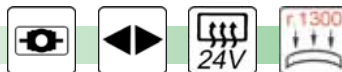

o.r. 93193198

ATTACCO A GHIERA/RING CLAMP mm 440x220

DAILY



I
V
E
C
O

I
V
E
C
O



0648.450D

o.r. 93936853

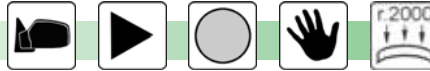

0648.450S

o.r. 93936852

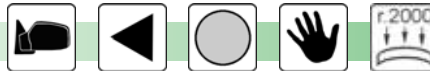

0648.451D

o.r. 93936849



0648.451S

o.r. 93936848



0648.453D

o.r. 93936851



0648.453S

o.r. 93936850



0648B.450D

o.r. 93936855



BRACCIO LUNGO / LONG ARM

0648B.450S

o.r. 93936854



BRACCIO LUNGO / LONG ARM

0648B.451D

o.r. 93936841



BRACCIO LUNGO / LONG ARM

0648B.451S

o.r. 93936840



BRACCIO LUNGO / LONG ARM

0648B.453D

o.r. 93936843



BRACCIO LUNGO / LONG ARM

0648B.453S

o.r. 93936842



BRACCIO LUNGO / LONG ARM

DAILY



0646.4500



0646.4510



0647.4530



1014.0100



o.r. 93160520 93160521









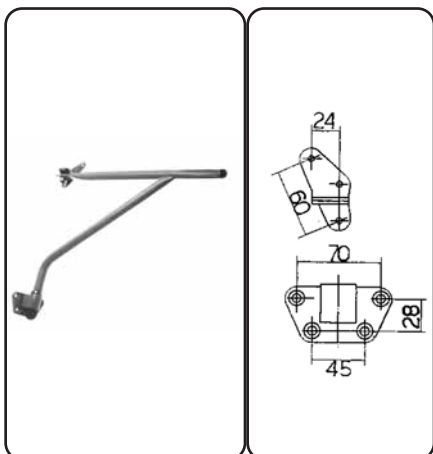



1014.0110



o.r. 93160518 93160519







615 / 616 N1-N2-N3-N4

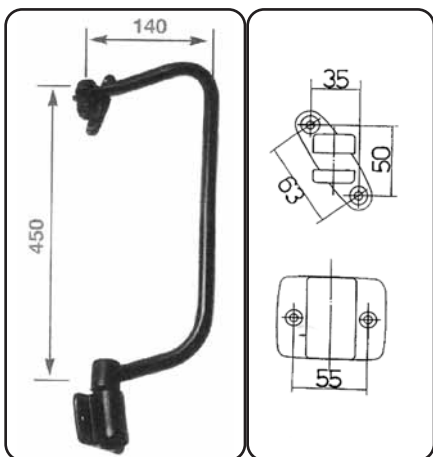

- 0781.100D   
- 0781.100S   
- 0781.200D   
- 0781.200S   







30 SC

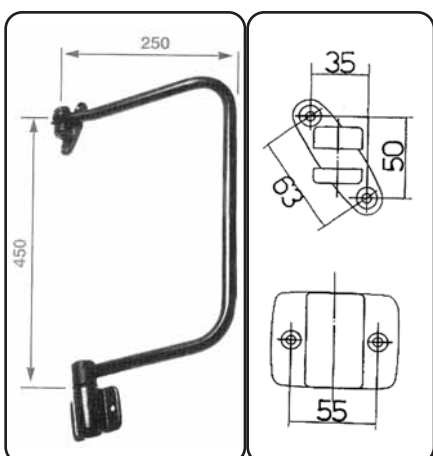

- 0831.100D   
- 0831.100S   

30 SC FURGONATO



- 0841.100D   
- 0841.100S   

FIAT 682 N4 / 682 T4 / 643 / 693 / 645 N-N1 / 650 N-N1 / 662 N-N1

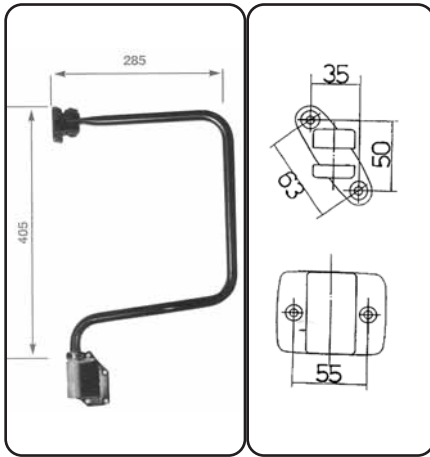

0811.100D



0811.100S



FIAT 190T / 170 NT35 / 190 F357 / 130 NC / 150 NR20 / 159 NC20 / OM 170/35 / 190/35 / 150/20

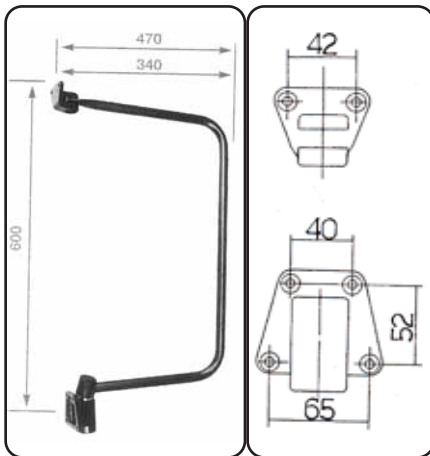

0901.100D



mm 340

0901.100S



mm 340

0901.300D



mm 340

0901.300S



mm 340

0901B.100D



mm 470

0901B.100S



mm 470

0901B.300D



mm 470

0901B.300S



mm 470

FIAT 170 NC / 170 NT25-33E / 190 NC / 190NT

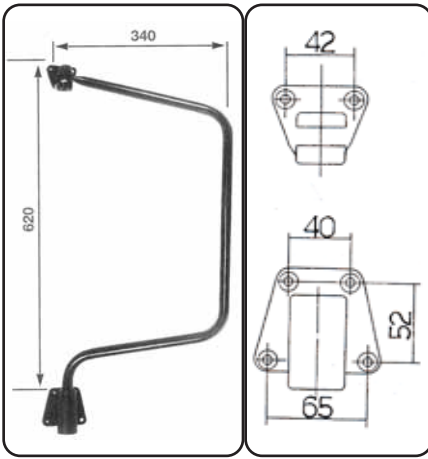

0771.100D



0771.100S



FIAT 50 NC / 60 NC / F9 / F10 / 65 F10 - 70 F10

OM 50 / 855 / 60 / 65 / 70 / 75 / 80 / 90 / 100 / MAGIRUS DEUTZ 90 M5.3

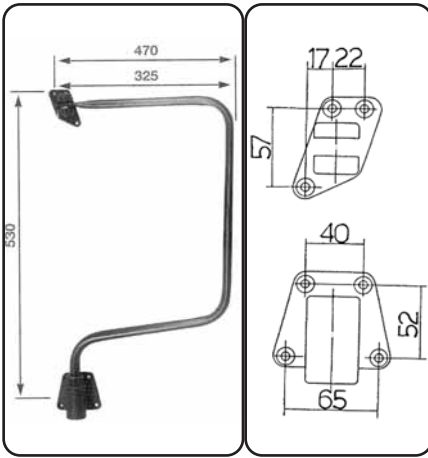

0807.100D

o.r. 9065443 9640074



mm 325

0807.100S

o.r. 9065444 9640075



mm 325

0807.300D



mm 325

0807.300S



mm 325

0807B.100D



mm 470

0807B.100S



mm 470

0807B.300D



mm 470

0807B.300S



mm 470

FIAT AUTOBUS 370 - IVECO

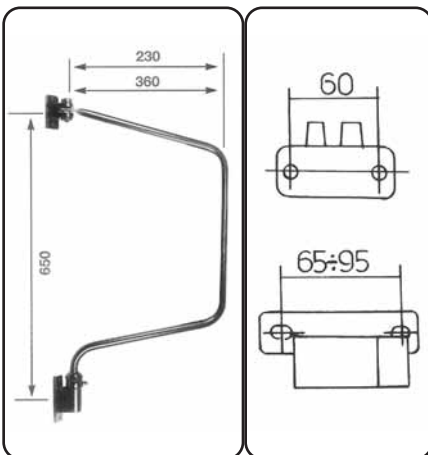

0931.100D



mm 360

0931.100S



mm 230

FIAT 100 / 110 / 130 / 160 / 619 / 639 / 684 / 697 / 300 OM 150 / 180NC

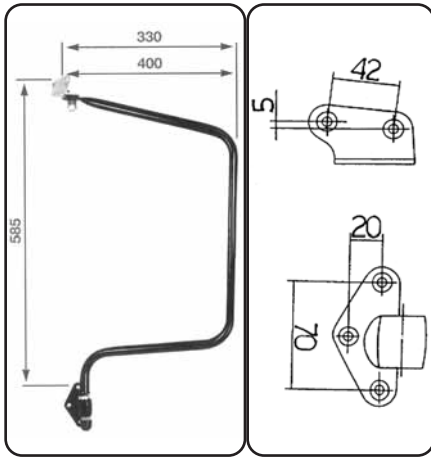

0821.100D



mm 330

0821.100S



mm 330

0821B.100D



mm 400

0821B.100S



mm 400

FIAT 50NC / 80NC / 90NC / 100NC / OM 50 / 55 / 60 / 65 / 70 / 75 / 80

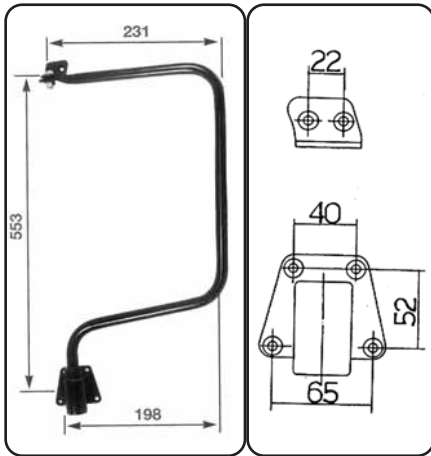

0762.100D



0762.100S



0762.200D



0762.200S



AUTOBUS

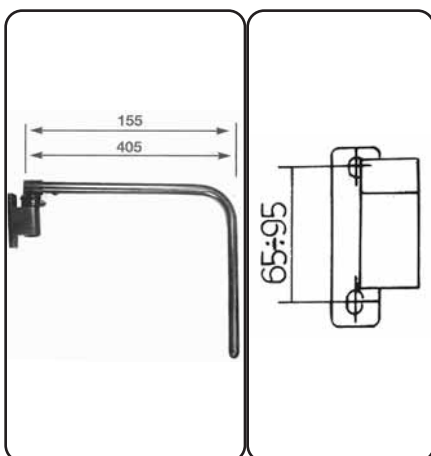

0911.100D



mm 405

0911.100S



mm 155

0912.100D



mm 155

0912.100S



mm 405

AUTOBUS

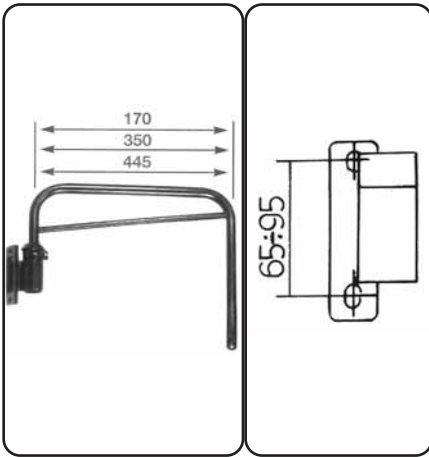

0961A.100D



mm 445

0961A.100S



mm 445

0961B.100D



mm 350

0961B.100S



mm 350

0961C.100D



mm 170

0961C.100S



mm 170

AUTOBUS

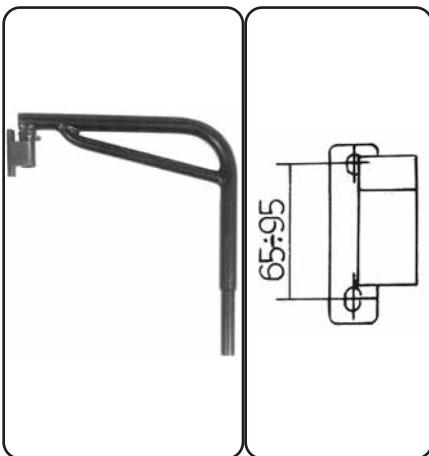

0909.100D



mm 300

0909.100S



mm 300

TURBOSTAR

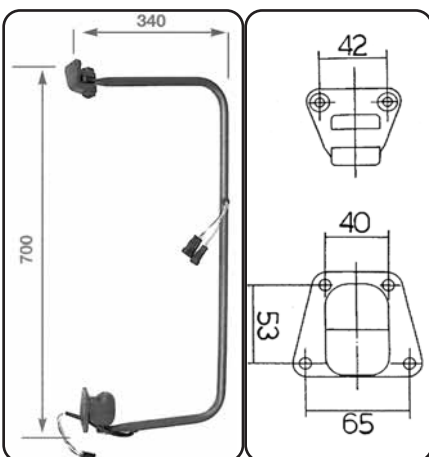

0893.303D



0893.303S





0733.11003



INTERASSE 50mm / WHEELBASE 50mm

0733.11103



INTERASSE 50mm / WHEELBASE 50mm

ALTERNATIVI ALL'ORIGINALE
ALTERNATIVE TO THE ORIGINAL ONE



0737.11003



INTERASSE 100mm / WHEELBASE 100mm

0737.11103



INTERASSE 100mm / WHEELBASE 100mm

ALTERNATIVI ALL'ORIGINALE
ALTERNATIVE TO THE ORIGINAL ONE



0944.17003



mm 200x200x15

0944.17103









mm 200x200x15

ALTERNATIVI ALL'ORIGINALE
ALTERNATIVE TO THE ORIGINAL ONE























TGA



- 1030.07003    mm 200x200
- 1030.07103     mm 200x200

ALTERNATIVI ALL'ORIGINALE
ALTERNATIVE TO THE ORIGINAL ONE



- (0745.12003)     0745.10003 + 0958.12003
- 0745.10003  
- 0958.12003    
- (0745.12103)      0745.10103 + 0958.12103
- 0745.10103   
- 0958.12103     



0733.11003



INTERASSE 50mm / WHEELBASE 50mm

0733.11103



INTERASSE 50mm / WHEELBASE 50mm

ALTERNATIVI ALL'ORIGINALE
ALTERNATIVE TO THE ORIGINAL ONE



0737.11003



INTERASSE 100mm / WHEELBASE 100mm

0737.11103



INTERASSE 100mm / WHEELBASE 100mm

ALTERNATIVI ALL'ORIGINALE
ALTERNATIVE TO THE ORIGINAL ONE



0944.17003



mm 200x200

0944.17103









mm 200x200

ALTERNATIVI ALL'ORIGINALE
ALTERNATIVE TO THE ORIGINAL ONE























TGL / TGM



- 1030.07003    mm 200x200
- 1030.07103     mm 200x200























ALTERNATIVI ALL'ORIGINALE
ALTERNATIVE TO THE ORIGINAL ONE



- (0962.12003)     0962.10003 + 0958.12003
- 0962.10003  
- 0958.12003    
- (0962.12103)      0962.10103 + 0958.12103
- 0962.10103   
- 0958.12103     

MODELLO CABINA ALTA
HIGH CAB MODEL



- (0817.12003)     0817.10003 + 0958.12003
- 0817.10003  
- 0958.12003    
- (0817.12103)      0817.10103 + 0958.12103
- 0817.10103   
- 0958.12103     

MODELLO CABINA BASSA
LOW CAB MODEL



0966.1700

o.r. 81637306314 81637306303



0966.1710

o.r. 81637306315 81637306365 81637306304 81637306366



0966.1730

o.r. 81637306316 81637306367 81637306305 81637306368



1036.07003

o.r. 81637330066



1036.07103

/o.r. 81637330067 81637330075



0046.1000





0933.1100						mm 380x185 Ø16-20	
o.r. 81637306126 81637306149							
0933.1110							mm 380x185 Ø16-20
o.r. 81637306151							
0934.1100						mm 380x185 Ø28	
0934.1110							mm 380x185 Ø28
1070.0100						mm 366x176	
o.r. 81637330025 81637330030							
1070.0110						mm 366x176	
o.r. 81637336003 81637336006							
0030.0000						mm 1000	

ACTROS / SKL / ECONIC

M
E
R
C
E
D
E
S

M
E
R
C
E
D
E
S



0948.14103

o.r. 0008109516+0018112033+0008111307



mm 433x188x68

0948.14303

o.r. 0008109416+0018112033+0008111307



mm 433x188x68



1029.04103

o.r. 0018112033



mm 433x188



0948.1000

o.r. 0008109516



0948.1030

o.r. 0008109416



ACTROS / SKL / ECONIC

M
E
R
C
E
D
E
S

M
E
R
C
E
D
E
S



4029.1000



ATTUATORE / ACTUATOR

PER COPPA 0948 / FOR HEAD 0948



0944.17003



mm 200x200

0944.17103



mm 200x200

o.r. 0008109616+0018109216+0008111307



1030.07003



mm 200x200

1030.07103



mm 200x200

o.r. 0018112133 0018109216



0944.1000



o.r. 0008109616

SENZA VETRO/WITHOUT GLASS mm 200x200



0048.0000

o.r. 0008111307

KIT FISSAGGIO / FIXING KIT



0733.11003



INTERASSE 50mm / WHEELBASE 50mm

0733.11103



INTERASSE 50mm / WHEELBASE 50mm

ALTERNATIVI ALL'ORIGINALE
ALTERNATIVE TO THE ORIGINAL ONE



0737.11003



INTERASSE 100mm / WHEELBASE 100mm

0737.11103



INTERASSE 100mm / WHEELBASE 100mm

ALTERNATIVI ALL'ORIGINALE
ALTERNATIVE TO THE ORIGINAL ONE



(0749.12003)



0749.10003 + 0958.12003

0749.10003



0958.12003



(0749.12103)



0749.10103 + 0958.12103

0749.10103



0958.12103





0944.17003



mm 200x200

0944.17103



mm 200x200

o.r. 0008109616+0018109216+0008111307



1030.07003



mm 200x200

1030.07103



mm 200x200

o.r. 0018112133 0018109216



0944.1000



SENZA VETRO/WITHOUT GLASS mm 200x200

o.r. 0008109616

ATEGO (LKN) / AXOR



0048.0000

o.r. 0008111307

KIT FISSAGGIO / FIXING KIT



0733.11003



INTERASSE 50mm / WHEELBASE 50mm

0733.11103



INTERASSE 50mm / WHEELBASE 50mm

ALTERNATIVI ALL'ORIGINALE
ALTERNATIVE TO THE ORIGINAL ONE



0737.11003



INTERASSE 100mm / WHEELBASE 100mm

0737.11103



INTERASSE 100mm / WHEELBASE 100mm



ALTERNATIVI ALL'ORIGINALE
ALTERNATIVE TO THE ORIGINAL ONE

ATEGO (LKN) / AXOR







MODELLO CABINA ALTA

HIGH CAB MODEL

(0816.12003)     0816.10003 + 0958.12003

0816.10003  

0958.12003    

(0816.12103)      0816.10103 + 0958.12103



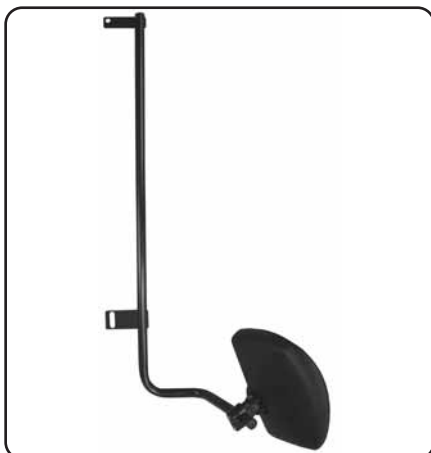

0816.10103   

0958.12103     







MODELLO CABINA BASSA

LOW CAB MODEL

(0812.12003)     0812.10003 + 0958.12003

0812.10003  

0958.12003    

(0812.12103)      0812.10103 + 0958.12103

0812.10103   

0958.12103     



0952.1100						mm 370x184	
o.r. 3818102516 3818107116							
0952.1110							mm 370x184
o.r. 3818102616 3818107316							
1076.0100						mm 354x168	
o.r. 0008112133 0008113333							
1076.0110						mm 354x168	
0030.0000						mm 1000	



0954.1100						mm 420x200	
o.r. 3818103716							
0954.1110							mm 420x200
o.r. 3818103816							
1078.0100						mm 408x185,5	
o.r. 0008113433							
1078.0110						mm 408x185,5	
o.r. 0008113833							
0030.0000						mm 1000	



0960.31003

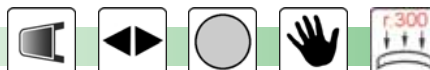

0960.31103



ALTERNATIVI ALL'ORIGINALE
ALTERNATIVE TO THE ORIGINAL ONE



0959.31003



0959.31103



0039.1000

KIT DI FISSAGGIO / FIXING KIT

ALTERNATIVI ALL'ORIGINALE
ALTERNATIVE TO THE ORIGINAL ONE

MAGNUM



0975.1710



0975.173D

o.r. 5001842202



0975.173S

o.r. 5001838475



0051.1000

o.r. 5000289392



1039.07003



1039.07103

o.r. 5000289377



MAGNUM



4039.100D



ATTUATORE/ACTUATOR

4039.100S



ATTUATORE/ACTUATOR



0979.17003



0979.17103



ALTERNATIVI ALL'ORIGINALE
ALTERNATIVE TO THE ORIGINAL ONE



1030.07003



1030.07103



ALTERNATIVI ALL'ORIGINALE
ALTERNATIVE TO THE ORIGINAL ONE



0936.11003



0936.11103



ALTERNATIVI ALL'ORIGINALE
ALTERNATIVE TO THE ORIGINAL ONE

MAGNUM



(0814.12003)					0814.10003 + 0958.12003	
0814.10003						
0958.12003						
(0814.12103)						0814.10103 + 0958.1210.
0814.10103						
0958.12103						



0904.14003

o.r. 5001853675



0904.14103



0904.14303

o.r. 5001856290



0044.1000

o.r. 5001833509



1015.04003



1015.04103

o.r. 5001856614



4015.1000



ATTUATORE/ACTUATOR

PREMIUM / MIDLUM / KERAX



0986.17003



0986.17103



ALTERNATIVI ALL'ORIGINALE
ALTERNATIVE TO THE ORIGINAL ONE



1030.07003



1030.07103



ALTERNATIVI ALL'ORIGINALE
ALTERNATIVE TO THE ORIGINAL ONE



PREMIUM/KERAX

0938.11003



0938.11103



ALTERNATIVI ALL'ORIGINALE
ALTERNATIVE TO THE ORIGINAL ONE



MIDLUM

0987.11003



0987.11103



ALTERNATIVI ALL'ORIGINALE
ALTERNATIVE TO THE ORIGINAL ONE



0950.1100

o.r. 316623 1106953



LAMIERA/SHEET

0950.1110

o.r. 316624 1106955



LAMIERA/SHEET

1075.0100

o.r. 296538



1075.0110

o.r. 296538+376243



0951.1100

o.r. 296171 175526 256646



LAMIERA/SHEET

0951.1110



LAMIERA/SHEET

1095.0100

o.r. 316918 176297



1095.0110



0949.1100

o.r. 316920 1622446



LAMIERA/SHEET

1095.0100

o.r. 316918 176297





0973.171D



0973.171S



0973.173D

o.r. 1723519



0973.173S

o.r. 1723518



0976.171D

o.r. 1765809



0976.171S

o.r. 1765809



1019.07003

o.r. 1346377 1442706



1019.07103

o.r. 1765985 1346378 1442705 1732776





1020.07003



1020.07103

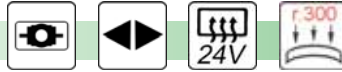

o.r. 1767265 7005158



4019.1000



ATTUATORE / ACTUATOR



0733.11003



INTERASSE 50mm / WHEELBASE 50mm

0733.11103



INTERASSE 50mm / WHEELBASE 50mm

ALTERNATIVI ALL'ORIGINALE
ALTERNATIVE TO THE ORIGINAL ONE



0737.11003



INTERASSE 100mm / WHEELBASE 100mm

0737.11103



INTERASSE 100mm / WHEELBASE 100mm

ALTERNATIVI ALL'ORIGINALE
ALTERNATIVE TO THE ORIGINAL ONE



LOW CAB

NORMAL CAB

(0812.12003)     **0812.10003 + 0958.12003**

0812.10003  

0958.12003    

(0812.12103)      **0812.10103 + 0958.12103**

0812.10103   

0958.12103     







TOPLINE

(0810.12003)     **0810.10003 + 0958.12003**

0810.10003  

0958.12003    

(0810.12103)      **0810.10103 + 0958.12103**

0810.10103   

0958.12103     



0947.1700



0947.1710



0947.1730



0947.1010



o.r. 3091256



0946.170D



0946.171D



0946.173D



0946.101D



o.r. 3091259

946.170S



0946.171S



0946.173S



0946.101S



FH / FL / FM 1^a SERIE



1024.07003

o.r. 3090736 20455986



1024.07103

o.r. 3092854 20854564

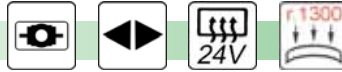

1026.07003

o.r. 3090738



1026.07103

o.r. 3081757 21203311

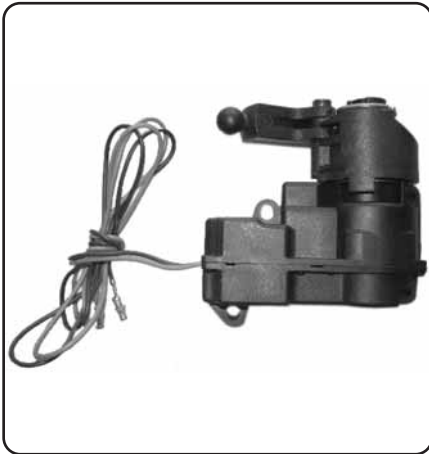
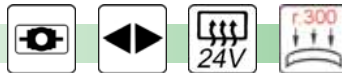

4024.1000

o.r. 3092041

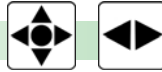

ATTUATORE / ACTUATOR

FH / FL / FM 1ª SERIE



- 0733.11003 INTERASSE 50mm / WHEELBASE 50mm
- 0733.11103 INTERASSE 50mm / WHEELBASE 50mm

ALTERNATIVI ALL'ORIGINALE
ALTERNATIVE TO THE ORIGINAL ONE



- 0737.11003 INTERASSE 100mm / WHEELBASE 100mm
- 0737.11103 INTERASSE 100mm / WHEELBASE 100mm

ALTERNATIVI ALL'ORIGINALE
ALTERNATIVE TO THE ORIGINAL ONE



- (0740.12003) 0740.10003 + 0958.12003
- 0740.10003 0740.10103 + 0958.12103
- 0958.12003 0740.10103 + 0958.12103
- (0740.12103) 0740.10103 + 0958.12103
- 0740.10103 0740.10103 + 0958.12103
- 0958.12103 0740.10103 + 0958.12103



0978.171D



0978.171S



0978.173D



0978.173S



0052.1000



o.r. 20746401



1027.04003



1027.04103



o.r. 21320383 20455986 20452886

FH / FL / FM 2^a SERIE



0977.171D



0977.171S



0053.1000



o.r. 20360811



1028.07003



o.r.

1028.07103



o.r. 20567685 21320300



4027.100D



o.r. 20742489 20757533



4027.100S



o.r. 20742488 20757531



FH / FL / FM 2^a SERIE



- 0733.11003  INTERASSE 50mm / WHEELBASE 50mm
- 0733.11103  INTERASSE 50mm / WHEELBASE 50mm







ALTERNATIVI ALL'ORIGINALE
ALTERNATIVE TO THE ORIGINAL ONE



- 0737.11003  INTERASSE 100mm / WHEELBASE 100mm
- 0737.11103  INTERASSE 100mm / WHEELBASE 100mm

ALTERNATIVI ALL'ORIGINALE
ALTERNATIVE TO THE ORIGINAL ONE



- (0753.12003)  0753.10003 + 0958.12003
- 0753.10003 
- 0958.12003  0753.10103 + 0958.12103
- (0753.12103)  0753.10103 + 0958.12103
- 0753.10103 
- 0958.12103 



0932.1100						mm 380x185	
0932.1110							mm 380x185
1070.0100						mm 366x176	
1070.0110						mm 366x176	
0030.0000						mm 1000	



0933.1100						mm 380x185 <u>Ø16-20</u>	
0933.1110							mm 380x185 <u>Ø16-20</u>
0934.1100						mm 380x185 <u>Ø28</u>	
0934.1110							mm 380x185 <u>Ø28</u>
1070.0100						mm 366x176	
1070.0110						mm 366x176	
0030.0000						mm 1000	



0672.1100						mm 245x155	
0672.1110							mm 245x155
0672.1140							mm 245x155
0030.0000						mm 1000	



0885.1100  mm 260X148

0885.1110  mm 260X148

0030.0000  mm 1000



0741.2100  LAMIERA/SHEET mm 260x180

1008.0100  mm 249x167



0641.1100  mm 190x140

1051.0100  mm 179x131



0889.1100  mm 190x140



0698.1100



mm 260X148

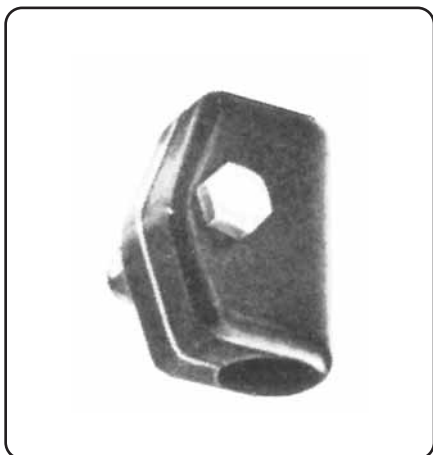

0736.1000



MORSETTO ALLUMINIO / ALUMINIUM CLAMP Ø20

0736.3000



MORSETTO ALLUMINIO / ALUMINIUM CLAMP Ø20



0735.1000



MORSETTO NYLON / NYLON CLAMP Ø18-20

0735.3000



MORSETTO NYLON / NYLON CLAMP Ø18-20

0734.1000



MORSETTO NYLON / NYLON CLAMP Ø22



0030.0000





4001.1000



ATTUATORE / ACTUATOR 24v

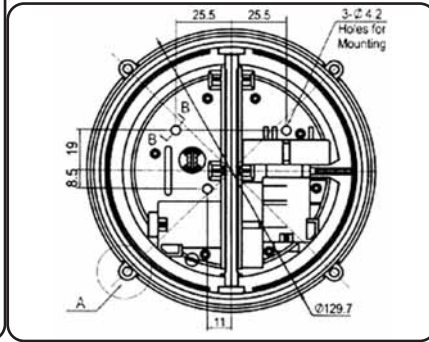

4002.1000



ATTUATORE / ACTUATOR 24v

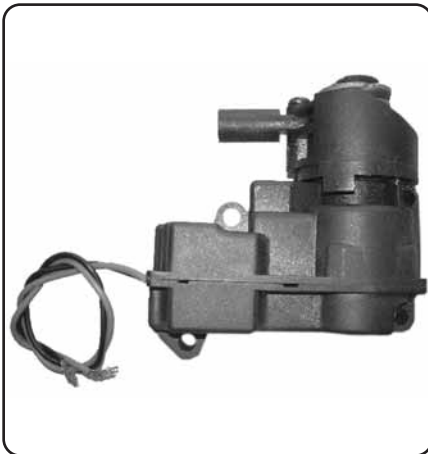
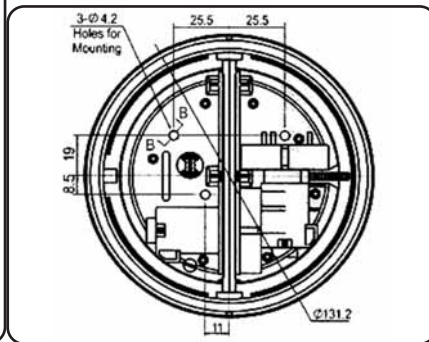

4003.1000



ATTUATORE / ACTUATOR 24v

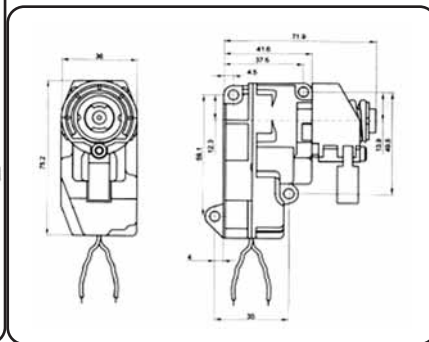



4005.1000



ATTUATORE / ACTUATOR 24v

4004.1000



ATTUATORE / ACTUATOR 12v

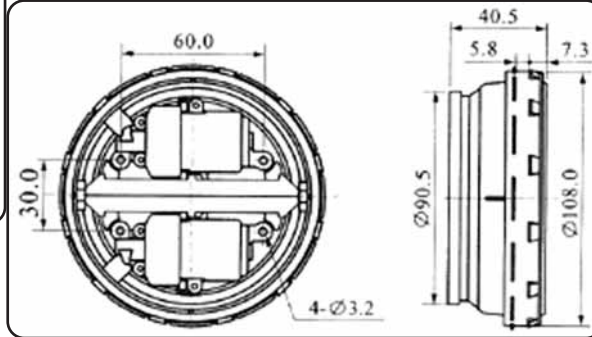

0031.1000



JOYSTICK 24v

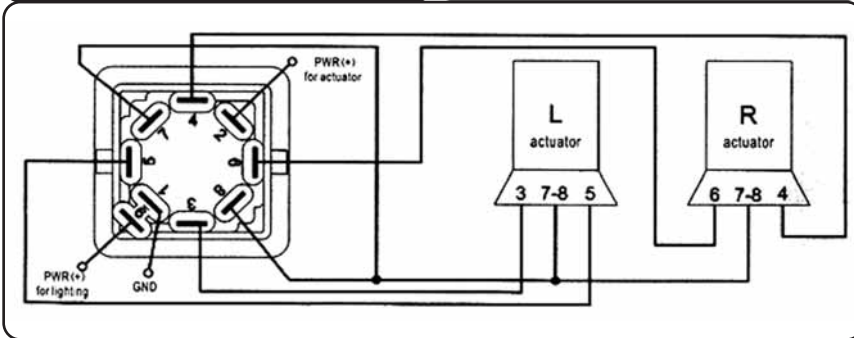
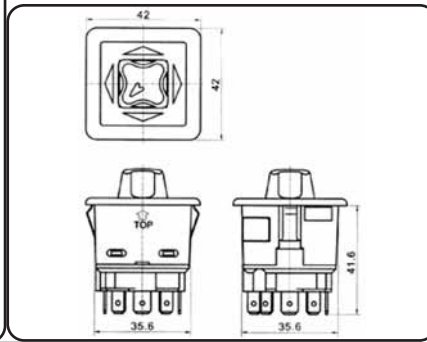



ARSAUTO s.r.l.

VEICOLI COMMERCIALI COMMERCIAL VEHICLES

Tutti i dispositivi retrovisori sono omologati presso il Centro Prove del Ministero dei Trasporti Italiano, prodotti in Italia, con componenti provenienti dalla UE.

All the rear view mirrors have been homologated by the Test Center of Italian Ministry of Transport, produced in Italy, with UE materials.

Alle die Spiegel sind bei dem Testzentrum vom Italienische Ministerium fuer Verkehr getestet, mit Material von UE.

Tous les rétroviseurs sont homologués par le Centre des Epreuves du Ministère des Transports Italien, produit en Italie, avec matériels UE.



0640.1100

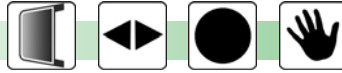

mm 190x140

1051.0100



mm 179x131



0639.100D



BASE BOMBATA / CONVEX FIXING

0639.100S



BASE BOMBATA / CONVEX FIXING

0645.100D



BASE PIATTA / FLAT FIXING

0645.100S



BASE PIATTA / FLAT FIXING



0684.110D

o.r. 4457818 9641018 5892132



0684.110S

o.r. 4457819 9641019 5892131

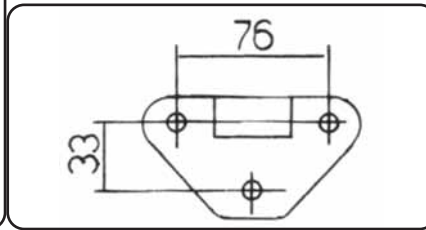

242 1° TIPO



0779.1100

o.r. 9958752



mm 230x180

0779.2100

o.r. 9054137



mm 230x180

1057.0100



mm 222x172

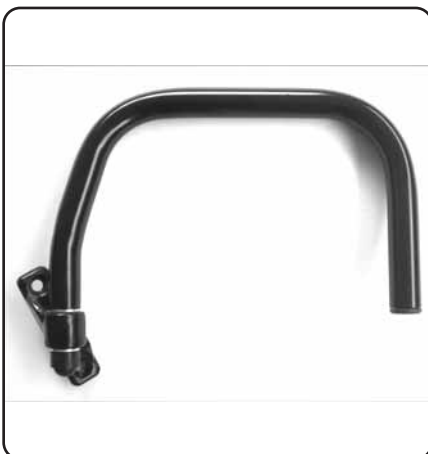

0786.100D



mm 190

0786.100S



mm 190



0777.1100

o.r. 9958752



SENZA MORSETTO/WITHOUT CLAMP mm 346x162

0777.2100

o.r. 9054137

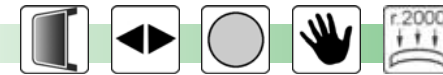

SENZA MORSETTO/WITHOUT CLAMP mm 346x162

1057.0100

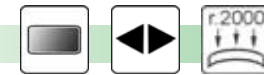

0776.100D



0776.100S



0776.200D



0776.200S



C35L ('80>) / 242E



0680.110D

o.r. 5536230 556238



0680.110S

o.r. 5536231 5562389

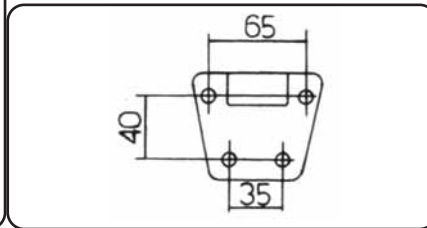

C25 (>'91) / 238 ('80>) / J5 (>'91)



0682.110D

o.r. 4464352 5920891 93908143 95651073



0682.110S

o.r. 4464353 5920893 93908144 95651072

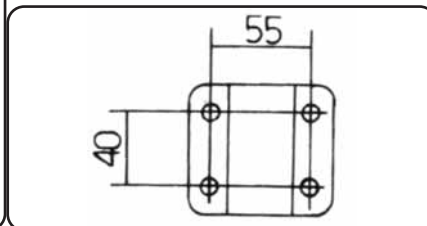

C25 ('91-'94) / DUCATO-TALENTO (>'94) / J5 ('91-'94)



0658.110D

o.r. 7684288



0658.110S

o.r. 7684289



0657.111D



0657.111S



0659.111D

o.r. 7778693



0659.111S

o.r. 7778694



0658B.110D

o.r. 7684291



BRACCIO LUNGO / LONG ARM

0658B.110S

o.r. 7684292



BRACCIO LUNGO / LONG ARM

0657B.111D



BRACCIO LUNGO / LONG ARM

0657B.111S



BRACCIO LUNGO / LONG ARM

0659B.111D

o.r. 7795098



BRACCIO LUNGO / LONG ARM

0659B.111S

o.r. 7795097



BRACCIO LUNGO / LONG ARM

C25 ('91-'94) / DUCATO-TALENTO (>'94) / J5 ('91-'94)



0667.110D      

CON VETRO / WITH GLASS mm 280x180

0667.110S      

CON VETRO / WITH GLASS mm 280x180

0670.111D      

CON VETRO / WITH GLASS mm 280x180

0670.111S      

CON VETRO / WITH GLASS mm 280x180

0668.111D      

CON VETRO / WITH GLASS mm 280x180

0668.111S      

CON VETRO / WITH GLASS mm 280x180



1014.0100   

1014.0110    

JUMPER ('94-'99) / DUCATO ('94-'99) / BOXER ('94-'99)



0618.150D

o.r. 1312468080



0618.150S

o.r. 1312467080



0618.154D



0618.154S



0618.153D

o.r. 1314490080



0618.153S

o.r. 1314489080



0618B.150D

o.r. 1313323080



BRACCIO LUNGO / LONG ARM

0618B.150S

o.r. 1313322080



BRACCIO LUNGO / LONG ARM

0618B.154D



BRACCIO LUNGO / LONG ARM

0618B.154S



BRACCIO LUNGO / LONG ARM

0618B.153D

o.r. 1314494080



BRACCIO LUNGO / LONG ARM

0618B.153S

o.r. 1314493080



BRACCIO LUNGO / LONG ARM

JUMPER ('94-'99) / DUCATO ('94-'99) / BOXER ('94-'99)



0667.110D						
CON VETRO / WITH GLASS mm 280x180						
0667.110S						
CON VETRO / WITH GLASS mm 280x180						
0670.111D						
CON VETRO / WITH GLASS mm 280x180						
0670.111S						
CON VETRO / WITH GLASS mm 280x180						
0668.111D						
CON VETRO / WITH GLASS mm 280x180						
0668.111S						
CON VETRO / WITH GLASS mm 280x180						



1014.0100			
1014.0110			

F
I
A
T

C
I
T
R
O
E
N

P
E
U
G
E
O
T

F
I
A
T

C
I
T
R
O
E
N

P
E
U
G
E
O
T

JUMPER ('99>) / DUCATO ('99>) / BOXER ('99>)



0619.150D

o.r. 1325626080



0619.150S

o.r. 1325627080



0619.154D



0619.154S



0619.153D

o.r. 1325619080



0619.153S

o.r. 1325618080



0619B.150D

o.r. 1325628080



BRACCIO LUNGO / LONG ARM

0619B.150S

o.r. 1325629080



BRACCIO LUNGO / LONG ARM

0619B.154D



BRACCIO LUNGO / LONG ARM

0619B.154S



BRACCIO LUNGO / LONG ARM

0619B.153D

o.r. 1325621080



BRACCIO LUNGO / LONG ARM

0619B.153S

o.r. 1325620080



BRACCIO LUNGO / LONG ARM

CITROËN

FIAT

PEUGEOT

CITROËN

FIAT

PEUGEOT

JUMPER ('99>) / DUCATO ('99>) / BOXER ('99>)



0630.150D						
0630.150S						
0630.154D						
0630.154S						
0630.153D						
0630.153S						



1022.050D				
o.r. 71716701				
1022.050S				
o.r. 71716702				
1022.051D				
1022.051S				



1023.050D					
o.r. 71716698	CON SUPPORTO INTERNO/WITH INTERNAL SUPPORT				
1023.050S					
o.r. 71716697	CON SUPPORTO INTERNO/WITH INTERNAL SUPPORT				
1023.051D					
	CON SUPPORTO INTERNO/WITH INTERNAL SUPPORT				
1023.051S					
	CON SUPPORTO INTERNO/WITH INTERNAL SUPPORT				

JUMPER ('99>) / DUCATO ('99>) / BOXER ('99>)



1021.050D				
1021.050S				
1021.051D				
1021.051S				

L 207



0894.1100						mm 245x155
o.r. 6118100016 6118100116						
0894.1110						mm 245x155
0894.1140						mm 245x155
1200.0100						mm 235x145
o.r. 6118110033 6118110133						
1200.0110						mm 235x145
1200.0140						mm 235x145
0030.0000						mm 1000



0886.1100						
o.r. 4168100416 FENDT E258514270020						
0886.1110						
1081.0100						
o.r. 0008116833						
1081.0110						
0030.0000						mm 1000

INDICE CODICI ARSAUTO

0030.0000	62	0648B.451D	24	0745.12103	32	0814.12103	47
0031.1000	61	0648B.451S	24	0749.10003	39	0816.10003	42
0036.1000	7	0648B.453D	24	0749.10103	39	0816.10103	42
0036.3000	7	0648B.453S	24	0749.12003	39	0816.12003	42
0037.3000	9 15 23	0657.111D	69	0749.12103	39	0816.12103	42
0038.3000	10 16	0657.111S	69	0753.10003	59	0817.10003	34
0039.1000	44	0657B.111D	69	0753.10103	59	0817.10103	34
0040.3000	11	0657B.111S	69	0753.12003	59	0817.12003	34
0044.1000	48	0658.110D	69	0753.12103	59	0817.12103	34
0046.1000	1 35	0658.110S	69	0759.10003	20	0818.10003	12 19 21
0048.1000	39 41	0658B.110D	69	0759.10103	20	0818.10103	12 19 21
0051.1000	45	0658B.110S	69	0759.12003	20	0818.12003	12 19 21
0052.1000	57	0659.111D	69	0759.12103	20	0818.12103	12 19 21
0053.1000	58	0659.111S	69	0762.100D	29	0821.100D	29
0618.150D	71	0659B.111D	69	0762.100S	29	0821.100S	29
0618.150S	71	0659B.111S	69	0762.200D	29	0821B.100D	29
0618.153D	71	0667.110D	70 72	0762.200S	29	0821B.100S	29
0618.153S	71	0667.110S	70 72	0771.100D	28	0823.301D	22
0618.154D	71	0668.111D	70 72	0771.100S	28	0823.301S	22
0618.154S	71	0668.111S	70 72	0772.1100	6	0823.303D	22
0618B.150D	71	0670.111D	70 72	0773.1100	6	0823.303S	22
0618B.150S	71	0670.111S	70 72	0773.1110	6	0824.351D	22
0618B.153D	71	0672.1100	60	0776.100D	67	0824.351S	22
0618B.153S	71	0672.1110	60	0776.100S	67	0824.353D	22
0618B.154D	71	0672.1140	60	0776.200D	67	0824.353S	22
0618B.154S	71	0680.110D	68	0776.200S	67	0831.100D	26
0619.150D	73	0680.110S	68	0777.1100	67	0831.100S	26
0619.150S	73	0682.110D	68	0777.2100	67	0841.100D	26
0619.153D	73	0682.110S	68	0779.1100	66	0841.100S	26
0619.153S	73	0684.110D	66	0779.2100	66	0885.1100	61
0619.154D	73	0684.110S	66	0781.100D	26	0885.1110	61
0619.154S	73	0698.1100	62	0781.100S	26	0886.1100	76
0619B.150D	73	0733.11003	2 31 33	0781.200D	26	0886.1110	76
0619B.150S	73		39 41 52	0781.200S	26	0889.1100	61
0619B.153D	73		56 59	0786.100D	66	0893.303D	30
0619B.153S	73	0733.11103	2 31 33	0786.100S	66	0893.303S	30
0619B.154D	73		39 41 52	0799.10003	3	0894.1100	76
0619B.154S	73		56 59	0799.10103	3	0894.1110	76
0630.150D	74	0734.1000	62	0799.12003	3	0894.1140	76
0630.150S	74	0735.1000	62	0799.12103	3	0901.100D	27
0630.153D	74	0735.3000	62	0807.100D	28	0901.100S	27
0630.153S	74	0736.1000	62	0807.100S	28	0901.300D	27
0630.154D	74	0736.3000	62	0807.300D	28	0901.300S	27
0630.154S	74	0737.11003	2	0807.300S	28	0901B.100D	27
0639.100D	65	0737.11103	2	0807B.100D	28	0901B.100S	27
0639.100S	65	0740.10003	56	0807B.100S	28	0901B.300D	27
0640.1100	65	0740.10103	56	0807B.300D	28	0901B.300S	27
0641.1100	61	0740.12003	56	0807B.300S	28	0902.1100	5 13
0645.100D	65	0740.12103	56	0810.10003	53	0902.1110	5 13
0645.100S	65	0741.2100	61	0810.10103	53	0902.1140	5 13
0646.4500	25	0742.10003	3	0810.12003	53	0902.3100	5 13
0646.4510	25	0742.10103	3	0810.12103	53	0902.3110	5 13
0647.4530	25	0742.12003	3	0811.100D	27	0904.14003	48
0648.450D	24	0742.12103	3	0811.100S	27	0904.14103	48
0648.450S	24	0744.10003	19	0812.10003	42 53	0904.14303	48
0648.451D	24	0744.10103	19	0812.10103	42 53	0905.1100	4
0648.451S	24	0744.12003	19	0812.12003	42 53	0905.1110	4
0648.453D	24	0744.12103	19	0812.12103	42 53	0905.1140	4
0648.453S	24	0745.10003	32	0814.10003	47	0905.3100	4
0648B.450D	24	0745.10103	32	0814.10103	47	0905.3110	4
0648B.450S	24	0745.12003	32	0814.12003	47	0908.16303	7

INDICE CODICI ARSAUTO

0908.36003	7	0952.1100	43	1014.0100	25	70	72	1059.0110	5	13
0908.36103	7	0952.1110	43	1014.0110	25	70	72	1059.0140	5	13
0908.36303	7	0954.1100	43	1015.04003	48			1065.0100	4	
0909.100D	30	0954.1110	43	1015.04103	48			1065.0110	4	
0909.100S	30	0958.12003		1016.07003	9	15	23	1065.0140	4	
0911.100D	29	0958.12103		1016.07103	9	15	23	1070.0100	36	60
0911.100S	29	0959.11003	8 18	1017.07003	10	16		1070.0100	36	60
0912.100D	29	0959.11103	8 18	1017.07103	10	16		1075.0100	50	
0912.100S	29	0959.31003	8 18 44	1018.07003	11	17		1075.0110	50	
0916.1100	6 14	0959.31103	8 18 44	1018.07103	11	17		1076.0100	43	
0916.1110	6 14	0960.11003	8 17	1019.07003	51			1076.0110	43	
0916.1140	6 14	0960.11103	8 17	1019.07103	51			1078.0100	43	
0916.3100	6 14	0960.31003	8 17 44	1020.07003	52			1078.0110	43	
0916.3110	6 14	0960.31103	8 17 44	1020.07103	52			1081.0100	76	
0924.37003	9 15 22	0961A.100D	30	1021.050D	75			1081.0110	76	
0924.37103	9 15 22	0961A.100S	30	1021.050S	75			1095.0100	50	
0924.37303	9 15 22	0961B.100D	30	1021.051D	75			1095.0110	50	
0925.37003	10 16	0961B.100S	30	1021.051S	75			1200.0100	76	
0925.37103	10 16	0961C.100D	30	1022.050D	74			1200.0110	76	
0925.37303	10 16	0961C.100S	30	1022.050S	74			1200.0140	76	
0926.37003	11 17	0962.10003	34	1022.051D	74			4001.1000	63	
0926.37103	11 17	0962.10103	34	1022.051S	74			4002.1000	63	
0926.37303	11 17	0962.12003	34	1023.050D	74			4003.1000	63	
0931.100D	28	0962.12103	34	1023.050S	74			4004.1000	64	
0931.100S	28	0963.37003	12 18	1023.051D	74			4005.1000	64	
0932.1100	60	0963.37103	12 18	1023.051S	74			4013.1000	8	
0932.1110	60	0963.37303	12 18	1024.07003	55			4015.1000	48	
0933.1100	36 60	0966.1700	1 35	1024.07103	55			4016.1000	10	16
0933.1110	36 60	0966.1710	1 35	1025.07003	11 17			4019.1000	52	
0934.1100	36 60	0966.1730	1 35	1025.07103	11 17			4024.1000	55	
0934.1110	36 60	0973.171D	51	1026.07003	55			4025.1000	11	18
0936.11003	46	0973.171S	51	1026.07103	55			4027.100D	58	
0936.11103	46	0973.173D	51	1027.04003	57			4027.100S	58	
0938.11003	49	0973.173S	51	1027.04103	57			4029.1000	38	
0938.11103	49	0975.171D	45	1028.07003	58			4039.1000	46	
0944.1000	38 40	0975.171S	45	1028.07103	58					
0944.17003	2 31 33	0975.173D	45	1029.04103	37					
	38 40	0975.173S	45	1030.07003	2 32 34					
0944.17103	2 31 33	0976.171D	51		38 40 46					
	38 40	0976.171S	51		49					
0946.101D	54	0977.171D	58	1030.07103	2 32 34					
0946.101S	54	0977.171S	58		38 40 46					
0946.170D	54	0978.171D	57		49					
0946.170S	54	0978.171S	57	1032.07003	12 18					
0946.171D	54	0978.173D	57	1032.07103	12 18					
0946.171S	54	0978.173S	57	1033.07003	12 18					
0946.173D	54	0979.17003	46	1033.07103	12 18					
0946.173S	54	0979.17103	46	1034.0600	20 21					
0947.1010	54	0986.17003	49	1034.0610	20 21					
0947.1700	54	0986.17103	49	1035.0600	20 21					
0947.1710	54	0987.11003	49	1035.0610	20 21					
0947.1730	54	0987.11103	49	1036.07003	1 35					
0948.1000	37	1008.0100	61	1036.07103	1 35					
0948.1030	37	1010.06003	7	1039.07003	45					
0948.14103	37	1010.06103	7	1039.07103	45					
0948.14303	37	1011.07003	9 15 23	1051.0100	61					
0949.1100	50	1011.07103	9 15 23	1055.0100	6					
0950.1100	50	1012.07003	10 16	1056.0100	6					
0950.1110	50	1012.07103	10 16	1056.0110	6					
0951.1100	50	1013.06003	7	1057.0100	66 67					
0951.1110	50	1013.06103	7	1059.0100	5 13					

INDICE CODICI O.R.

DAF

DAF	ARSAUTO	PAG
1420104	0966.1710	1
1425105	0966.1730	1
1425109	1036.07103	1

DAF	ARSAUTO	PAG
1425113	0046.1000	1
1610184	0966.1730	1
1610186	0966.1710	1

DAF	ARSAUTO	PAG
1610190	1036.07103	1

IVECO

IVECO	ARSAUTO	PAG
29972253	1018.07103	11
29972254	1018.07003	11
42344326	0902.3100	5
42344326	0916.3100	6
42344895	0902.3110	5
42344895	0916.3110	6
42345778	0959.31003	8
42345778	0959.31003	18
42345780	0959.11003	8
42345780	0959.11003	18
42345783	0960.31003	8
42345783	0960.31003	17
42345784	0960.11003	8
42345784	0960.11003	17
42548403	1025.07103	11
42558713	1032.07103	12
4672587	1055.0100	6
4697662	0772.1100	6
4699450	0773.1100	6
4699450	1056.0100	6
4723931	0905.3100	4
4723931	0902.1100	5
4723931	0916.1100	6
4723936	1059.0100	5
4741047	0902.1110	5
4741047	0916.1110	6
4755582	0905.1100	4
4755585	1065.0100	4
4755870	0905.1110	4
4788351	0902.1110	5
4788351	0916.1110	6
4995043	0772.1100	6
504132242	0963.37003	12
504132243	0963.37103	12
504132244	0963.37303	12
504132248	0926.37103	11
504132249	0926.37303	11

IVECO	ARSAUTO	PAG
504197878	1034.0610	20
504197879	1035.0610	20
66800285	0908.36303	7
8468220	0773.1110	6
9065443	0807.100D	12
9065444	0807.100S	28
93139201	1033.07003	28
93156901	1013.06103	7
93160518	1014.0110	25
93160519	1014.0110	25
93160520	1014.0100	25
93160521	1014.0100	25
93160537	1010.06103	7
93171063	0037.3000	9
93172323	0824.351D	22
93172539	0824.353D	22
93172540	0824.353S	22
93173324	0824.351S	22
93190915	1065.0110	4
93190916	1059.0110	5
93190960	1033.07103	12
93190970	1017.07103	10
93190971	0038.3000	10
93190972	4016.1000	10
93190973	1025.07103	11
93190974	0040.3000	11
93190975	4025.1000	11
93190976	1016.07103	9
93190981	1016.07003	9
93190982	1025.07003	11
93190983	1017.07003	10
93190984	1032.07103	12
93193162	1011.07003	9
93193197	1012.07103	10
93193198	1011.07103	9
93193199	1018.07103	11
93193200	1012.07003	10

IVECO	ARSAUTO	PAG
93936840	0648B.451S	24
93936841	0648B.451D	24
93936842	0648B.453S	24
93936843	0648B.453D	24
93936848	0648.451S	24
93936849	0648.451D	24
93936850	0648.453S	24
93936851	0648.453D	24
93936852	0648.450S	24
93936853	0648.450D	24
93936854	0648B.450S	24
93936855	0648B.450D	24
9640074	0807.100D	8
9640075	0807.100S	17
98424102	0960.31003	28
98424102	0960.31003	28
98424110	0902.3110	5
98424110	0916.3110	6
98472976	0925.37003	10
98472977	0925.37103	10
98472979	0925.37303	10
98472981	0924.37003	9
98472982	0924.37103	9
98472983	0924.37303	9
98472986	0926.37003	11
98472987	0926.37103	11
98472989	0926.37303	11
98473005	0925.37003	10
98473006	0925.37103	10
98473007	0925.37303	10
98473008	0924.37003	9
98473010	0924.37103	9
98473011	0924.31303	9
98487460	1033.07103	12

MAN

MAN	ARSAUTO	PAG
81637306126	0933.1100	36
81637306149	0933.1100	36
81637306151	0933.1110	36
81637306303	0966.1700	35
81637306304	0966.1710	35
81637306305	0966.1730	35
81637306314	0966.1700	35

MAN	ARSAUTO	PAG
81637306315	0966.1710	35
81637306316	0966.1730	35
81637306365	0966.1710	35
81637306366	0966.1710	35
81637306367	0966.1730	35
81637306368	0966.1730	35
81637330025	1070.0100	36

MAN	ARSAUTO	PAG
81637330030	1070.0100	36
81637330066	1036.07003	35
81637330067	1036.07103	35
81637330075	1036.07103	35
81637336003	1070.0110	36
81637336006	1070.0110	36

INDICE CODICI O.R.

MERCEDES

MERCEDES	ARSAUTO	PAG
0008109416	0948.1030	37
0008109516	0948.1000	37
0008109616	0944.1000	38
0008111307	0048.0000	39
0008112133	1076.0100	43
0008113333	1076.0100	43
0008113433	1078.0100	43

MERCEDES	ARSAUTO	PAG
0008113833	1078.0110	43
0008116833	1081.0100	76
0018109216	1030.07103	38
0018112033	1029.04103	37
0018112133	1030.07103	38
3818102516	0952.1100	43
3818102616	0952.1110	43

MERCEDES	ARSAUTO	PAG
3818103716	0954.1100	43
3818103816	0954.1110	43
3818107116	0952.1100	43
3818107316	0952.1110	43
4168100416	0886.1100	76
6118100016	0894.1100	76
6118110033	1200.0100	76

RENAULT

RENAULT	ARSAUTO	PAG
5000289377	1039.07103	45
5000289378	4039.1000	46
5000289392	0051.1000	45

RENAULT	ARSAUTO	PAG
5001833509	0044.1000	48
5001838475	0975.173S	45
5001842202	0975.173D	45

RENAULT	ARSAUTO	PAG
5001853675	0904.14003	48
5001856290	0904.14303	48
5001856614	1015.04103	48

SCANIA

SCANIA	ARSAUTO	PAG
1106953	0950.1100	50
1106955	0950.1110	50
1346377	1019.07003	51
1346378	1019.07103	51
1442705	1019.07103	51
1442706	1019.07003	51
1622446	0949.1100	50
1723518	0973.173S	51
1723519	0973.173D	51

SCANIA	ARSAUTO	PAG
1732776	1019.07103	51
175526	0951.1100	50
176297	1095.0100	50
176297	1095.0100	50
1765809	0976.171D	51
1765809	0976.171S	51
1765985	1019.07103	51
1767265	1020.07103	52
256646	0951.1100	50

SCANIA	ARSAUTO	PAG
296171	0951.1100	50
296538	1075.0100	50
296538+376243	1075.0110	50
316623	0950.1100	50
316624	0950.1110	50
316918	1095.0100	50
316918	1095.0100	50
316920	0949.1100	50
7005158	1020.07103	52

VOLVO

VOLVO	ARSAUTO	PAG
20360811	0053.1000	58
20452886	1027.04103	57
20455986	1024.07003	55
20455986	1027.04103	57
20567685	1028.07103	58
20742488	4027.100S	58
20742489	4027.100D	58

VOLVO	ARSAUTO	PAG
20746401	0052.1000	57
20757531	4027.100S	58
20757533	4027.100D	58
20854564	1024.07103	55
21203311	1026.07103	55
21320300	1028.07103	58
21320383	1027.04103	57

VOLVO	ARSAUTO	PAG
3081757	1026.07103	55
3090736	1024.07003	55
3090738	1026.07003	55
3091256	0947.1010	54
3091259	0947.101D	54
3092041	4024.1000	55
3092854	1024.07103	55

Tutti i riferimenti originali e gli eventuali marchi dei costruttori dei veicoli, hanno solo valore indicativo, ai fini della identificazione del prodotto.

Arsauto srl, ha curato attentamente, la stesura del presente catalogo, ma declina comunque ogni responsabilità per errori relativi a modelli o a codici originali.

Arsauto srl si riserva il diritto di apportare modifiche al contenuto, senza obbligo di darne preventiva comunicazione.

All the O.E. codes and possible brands of vehicles manufacturers mentioned in this catalogue, are only for identification purposes.

Arsauto srl has focused the best attention on the editing of this catalogue, but they decline any responsibility for possible mistakes regarding drawings correspondence with O.E. codes.

Arsauto srl reserves the right to modify the contents without prior notice.



	COMPLETO VETTURA / FURGONE		BRACCIO GUARDAVANTI		CROMATO
	COPPA CON VETRO VETTURA / FURGONE		BRACCIO VEICOLI INDUSTRIALI		REGOLAZIONE MANUALE
	CALOTTA VETTURA / FURGONE		PIATTELLO CON VETRO RICAMBIO		REGOLAZIONE MECCANICA
	COPPA VEICOLI INDUSTRIALI		VETRO RICAMBIO		REGOLAZIONE ELETTRICA
	COPPA SENZA VETRO VEICOLI INDUSTRIALI		AMBIDESTRO		TERMICO 12v
	COPPA GRANDANGOLO VEICOLI INDUSTRIALI		DESTRO		TERMICO 24v
	COPPA GRAND.SENZA VETRO VEICOLI IND.		SINISTRO		CON SONDA
	CALOTTA VEICOLI INDUSTRIALI		NERO		RAGGIO DI CURVATURA
	GUARDAVANTI COMPLETO		GRIGIO		CAVO
	COPPA GUARDAVANTI		PRIMERIZZATO		



	COMPLETED CAR/ COMM. VEHICLES		FRONT MIRROR ARM		CHROMED
	HEAD WITH GLASS CAR/ COMM. VEHICLES		INDUSTRIAL VEHICLE ARM		MANUAL REGULATION
	HEAD COVER CAR/ COMM. VEHICLES		GLASSHOLDER WITH REPLACEMENT GLASS		MECHANICAL REGULATION
	HEAD WITH GLASS INDUSTRIAL VEHICLES		REPLACEMENT GLASS		ELECTRIC REGULATION
	HEAD WITHOUT GLASS INDUSTRIAL VEHICLES		AMBIDEXTROUS		THERMIC 12v
	WIDE HEAD WITH GLASS INDUSTRIAL VEHICLES		RIGHT		THERMIC 24v
	WIDE HEAD W/O GLASS INDUSTRIAL VEHICLES		LEFT		WITH THERMIC PROBE
	ARM COVER INDUSTRIAL VEHICLE		BLACK		BENDING RADIUS
	COMPLETED FRONT MIRROR		GREY		CABLE
	FRONT MIRROR HEAD		WITH PRIMER		



KOMPLETT
AUTO / VAN



GEHAESE MIT GLAS
AUTO / VAN



KAPPE AUTO / VAN



NUTZFAHRZEUGSGEHAESE



NUTZFAHRZEUGSGEHAESE
OHNE GLAS



NUTZFAHRZEUGSGEHAESE
WEITWINKELIG



NUTZFAHRZEUGSGEHAESE
WEITWINKELIG OHNE GLAS



KAPPE FUER
NUTZFAHRZEUGE



KOMPLET
FRONTSPIEGEL



GEHAESE MIT GLAS
FUER FRONTSPIEGEL



ARM FUER
FRONTSPIEGEL



ARM FUER
NUTZFAHRZEUGE



PLASTIKHALTER MIT
ERSATZGLAS



ERSATZGLAS



BEIDHAENDIG



RECHTS



LINKS



SCHWARZ



GRAU



GRUNDIERT



CHROMAT



MANUELLE
EINSTELLUNG



MECHANISCHE
EINSTELLUNG



ELEKTRISCHE
EINSTELLUNG



THERMISCH 12v



THERMISCH 24v



MIT SONDE



KRUEMMUNGSRADIUS



KABEL



COMPLET VOITURE /
VEHICULES COMMERCIALS



COUPELLE AVEC GLACE



CALOTTE VOITURE /
VEHICULES COMMERCIALS



COUPELLE
POIDS-LOURDS



COUPELLE SANS GLACE
POIDS-LOURDS



COUPELLE GRANDANGLE
POIDS-LOURDS



COUPELLE GRANDANGLE
SANS GLACE POIDS-LOURDS



CALOTTE
POIDS-LOURDS



ANTEVISEUR
COMPLET



COUPELLE
ANTEVISEUR



BRAS POUR
ANTEVISEUR



BRAS POUR
POIDS-LOURDS



PLAQUE AVEC MIRROIR



GLACE DE RECHANGE



DROIT ET GAUCHE



DROIT



GAUCHE



NOIR



GRIS



AVEC PRIMER



CHROME'



REGULATION MANUEL



REGULATION
MECHANIQUE



REGULATION
ELECTRIQUE



CHAUFFANT 12v



CHAUFFANT 24v



AVEC SONDE



RAYON DE CORBURE



CABLE



	COMPLETO COCHE / FURGON		BRAZO PARA ESPEJO FRONTAL		CROMADO
	ESPEJO CON VIDRIO COCHE / FURGON		BRAZO PARA VEHICULOS INDUSTRIALES		REGULACION MANUAL
	CAPA COCHE / FURGON		PLATO CON VIDRIO DE RECAMBIO		REGULACION MECANICA
	ESPEJO PARA VEHICULOS INDUSTRIALES		VIDRIO DE RECAMBIO		REGULACION ELETRICA
	ESPEJO SIN VIDRIO PARA VEHICULOS INDUSTRIALES		AMBIDEXTRO		TERMICO 12v
	ESP. GRAN ANGULAR PARA VEHICULOS INDUSTRIALES		DERECHO		TERMICO 24v
	ESP. GRAN ANGULAR SIN VID. PARA V. INDUSTRIALES		IZQUIERDO		CON SONDA
	CAPA PARA VEHICULOS INDUSTRIALES		NEGRO		RADIO DE CURVATURA
	ESPEJO FRONTAL COMPLETO		GRIS		CABLE
	ESPEJO FRONTAL		CON PRIMER		



	COMPLETO VEICULO / FURGÃO		BRAÇO VISÃO DIANTEIRA		CROMADO
	BASE COM VIDRO VEICULO / FURGÃO		BRAÇO PARA VEICULOS INDUSTRIAIS		REGULAGEM MANUAL
	CAPA VEICULO / FURGÃO		PLACA COM VIDRO REPOSIÇÃO		REGULAGEM MECÂNICA
	BASE VEICULOS INDUSTRIAIS		VIDRO REPOSIÇÃO		REGULAGEM ELÉTRICA
	BASE SEM VIDRO VEICULOS INDUSTRIAIS		DIREITO / ESQUERDO		TÉRMICO 12v
	BASE PANORAMICO VEICULOS INDUSTRIAIS		DIREITO		TÉRMICO 24v
	BASE PANORAMICO SEM VIDRO VEICULOS IND.		ESQUERDO		COM TERMOPAR
	CAPA VEICULOS INDUSTRIAIS		PRETO		RAIO DA CURVA
	VISÃO DIANTEIRA COMPLETO		CINZA		CABO
	BASEVISÃO DIANTEIRA		COM PRIMER		



ARSAUTO srl

C.so Mandelli, 10 10070 CAFASSE (TO)
 e-mail: a.ponti@r2a.it fax. 0123-340750
 Ufficio commerciale: 0123-340722 0123-340738
 Ufficio tecnico: 0123-340778 0123-340779